



The ORB™ 4-20 mA Input Box promotes communication from the 4-20 mA devices and transforms the data to a serial RS-422/485 communication for interfacing with other instruments and management equipment. The 4-20 mA Input Box enhances the communication ability of all the measuring and weighing devices as well as other devices such as temperature and moisture sensors.

HOW TO ORDER

ORB 420-01	4-20 mA Input Box for ORB; Includes (1) 4-Channel Input Board, (1) Power Supply, (1) Enclosure with Expansion Room for 3 Additional Input Boards
ORB 420-02	4-20 mA Input Box for ORB; Includes (2) 4-Channel Input Boards, (1) Power Supply, (1) Enclosure with Expansion Room for 2 Additional Input Boards
ORB 420-03	4-20 mA Input Box for ORB; Includes (3) 4-Channel Input Board, (1) Power Supply, (1) Enclosure with Expansion Room for 1 Additional Input Board
ORB 420-04	4-20 mA Input Box for ORB; Includes (4) 4-Channel Input Boards, (1) Power Supply, (1) Enclosure
SPK-ORB-420-01	4-Channel Input Board w/Mounting Hardware for ORB
4-20 mA Input Box with InvisiLink Wireless Radio	
(ORB 4-20mA PN)-B11	With InvisiLink Wireless Capabilities, Standard Antenna, RS-422
(ORB 4-20mA PN)-B21	With InvisiLink Wireless Capabilities, Extended Range Antenna, RS-422; includes 6 ft (1.8 m) Connection cable

FEATURES AND BENEFITS

Promotes Communication

- Converts 4-20 mA data into RS-422/485
- Allows 16 devices to be connected to a single input box
- Each data stream is addressed and communicated individually

All Devices Are Visible

- The ORB remote inventory management system can obtain and monitor information for any 4-20mA device at a location

InvisiLink™ Wireless Radio Option

- Eliminate costly wiring and conduit with direct communication between devices

4-20mA STANDARD SPECIFICATIONS

Power Supply	120 VAC
Communication	RS-422/485
Input	4-20mA
Addressing	8 position dip switches for binary addressing
Temperature	0 to 120°F (-17° to 48° C) Operating -20 to 150°F (-20° to 65° C) Storage Humidity: 0 to 100% non-condensing
Enclosure Size	6" x 8" x 10"
Board Size	3" x 5" x 0.75"
Enclosure	NEMA-4X, Fiberglass Reinforced Plastic

INVISILNK™ SPECIFICATIONS

FUNCTION	
Input/Output	RS-485, RS-422
Frequency	900 Mhz
Power Supply	120 VAC
Ambient temperature (Electronics)	-40° to 185° F (-40° to +85° C) 4-20 mA: 0° to 120° F (-17 to 48° C)
PERFORMANCE	
Transmission Speed (Baud Rate)	RS-485: 115.2 RS-422: 9600
Transmit Power	1 mW to 1 W
Transmission Distance	3000 ft (701 m)*
PHYSICAL	
Housing Material	NEMA 4X, Fiberglass
Extended Range Antenna	Up to 40 miles (64 km) NEMA 4X Outdoor includes lightning arrestor**
Visual Indicators	LED Lights (Power, Communication and Signal)

*Distances may be reduced depending on environment. Maximum distance determined in indoor/urban environment with direct line of sight, no obstacles.

** Consult Factory for extended range distances.

PRODUCT COMPATIBILITY

DEVICE	COMMUNICATION	
	RS-485	RS-422
Bindicator® 3D Level Scanner	x	
Bindicator Mark-4/GP-4 Yo-Yo	x	
Bindicator/Kistler-Morse ORB™		x
Bindicator/Kistler-Morse ORB 4-20mA Input Box		x
Bindicator SonoTracker		x
Kistler-Morse Ultrawave		x
Kistler-Morse MVS		x
Kistler-Morse STXplus		x
Kistler-Morse SVS2000		x
Kistler-Morse Weigh II		x
Niagara Meters 5600 Controller		x

Note: RS-485 Communication will be programmed at a baud rate of 115200; RS-422 Communication will be programmed at a baud rate of 9600.

DIMENSIONAL DRAWINGS

Standard 4-20mA Input Box

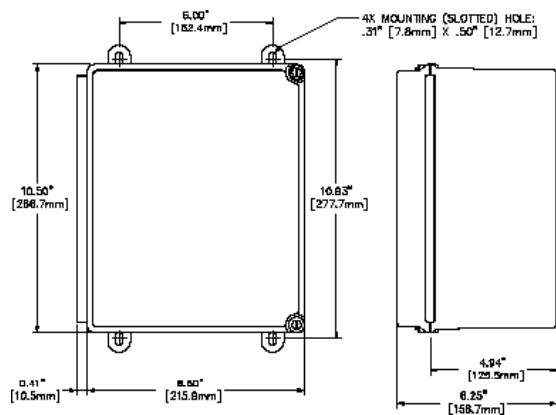

4-20mA Input Box with InvisiLink Wireless Radio

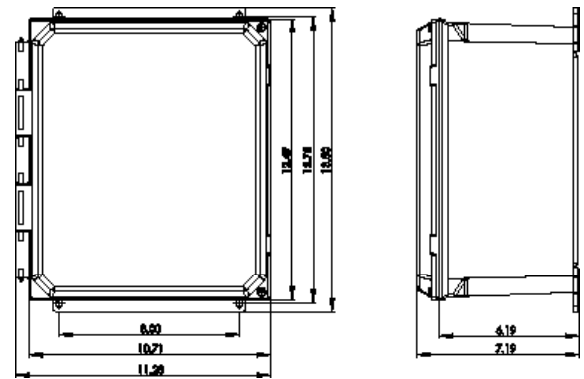

Extended Range (Optional) Antenna

