

# RF8200

## *Radio Frequency Level Probe with Lights*

### *Installation & Operation Manual*

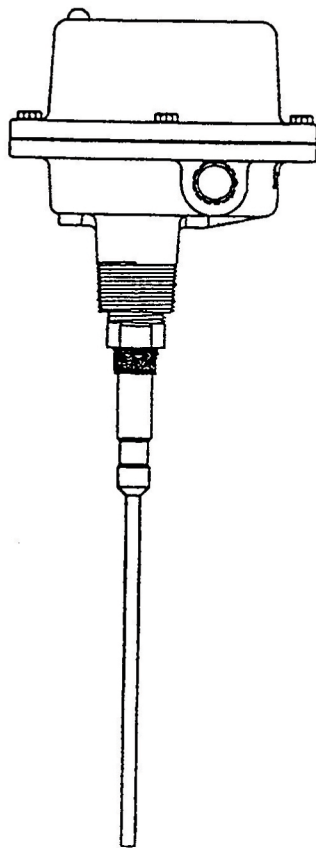

150 Venture Boulevard  
Spartanburg, SC 29306  
Phone: (864) 574-8060, Fax: (864) 574-8063  
Customer Service: (800) 778-9242  
Internet: [www.bindicator.com](http://www.bindicator.com)  
email: [sales@bindicator.com](mailto:sales@bindicator.com)

**RF8200**  
**Radio Frequency Probe with Lights**  
Installation and Operation Manual

<u>Section</u>	<u>Description</u>	<u>Page Number</u>
1.0	INTRODUCTION	1
1.1	Purpose and Use	1
1.2	Operating Theory	1
1.3	Special Features	1
2.0	SPECIFICATIONS	2
2.1	Electronics	2
2.2	Standard Duty Probe	2
2.3	Food Grade Probe	2
2.4	Stub Probe	2
2.5	Heavy Duty Probe	3
2.6	Standard Duty - Kynar Coated Probe	3
2.7	Heavy Duty - Kynar Coated Probe	3
2.8	Flush Probe	3
2.9	Enclosure	3
2.10	UL Listed Explosionproof	4
3.0	INSTALLATION	4
3.1	Location and Mounting	4
3.2	Wiring	5
3.3	Fail-Safe Selection	5
3.4	Time Delay Setting	5
3.5	Calibration	7
3.6	Verification	7
3.7	Function Test	7
4.0	APPLICATION CONSIDERATIONS	8
4.1	Installation Errors	8
4.2	Application Errors	8
4.2.1	Extreme Material Buildup	8
4.2.2	High Vibration	8
4.2.3	High Temperature	8
4.2.4	Highly Corrosive Materials	8
4.2.5	Extremely Light and Dry Materials	8
5.0	TROUBLESHOOTING	9
5.1	RF8200 Troubleshooting using a Voltmeter	9
5.2	RF8200 Probe Troubleshooting using an Ohmmeter	9
5.3	Factory Assistance	10
6.0	WARRANTY and PARTS	10
6.1	Warranty	10
6.2	Electronics Replacement	10
7.0	DRAWINGS	10
8.0	MODEL SELECTION	11

***Important!***  
***Do not dispose of the carton or packing material until the unit has been inspected for damage.***  
***If the unit is received damaged, notify the carrier or the factory for instructions.***  
***Failure to do so may void your warranty.***  
***Thank you!***

## 1.0 INTRODUCTION

### 1.1 Purpose and Use

The RF-8200 series are point level controls used to detect the presence or absence material at a point inside a tank, bin or other vessel.

Material coming in contact with the RF-8200 probe causes its output relay to change state; thereby indicating to the user material is present.

The RF-8200 utilizes the PRO-GUARD® principle to prevent false indications from material coating or moisture and condensation on the probe.

### 1.2 Operating Theory

The RF-8200 are relatively low-powered devices requiring approximately 4 watts for operation. The power supply can accept either 120VAC, 240VAC, 24VDC, or 12VDC (factory selectable) input power. A varistor is used to filter out line transients. A 153.6 KHZ RF oscillator provides the signal which is directed to both the PRO-GUARD® and active sensing area of the probe. (See Figure 1.)

Detection circuitry compares the signal flowing from the active sensing area towards ground (vessel wall) to a reference RF signal. Since all materials have dielectric constants (relative permittivity) and conductance values different from air, the impedance of the signal circuit changes when material touches the probe. This change causes a shift in phase of the RF signal. A phase difference between the active signal and reference signal causes output circuitry to operate.

Sensitivity adjustment determines how much phase shift is needed before the output relay changes state. Time delay selection determines how much time should elapse after detection until the output relay changes state. Fail-safe selection determines whether relay energizes or de-energizes when material is present.

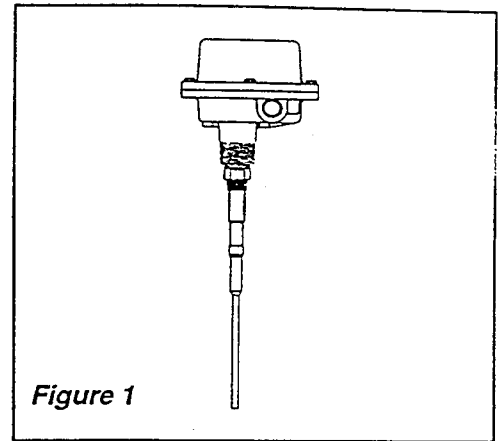

### 1.3 Special Features

All RF-8200 Series units have solid-state electronics, fail-safe output indication, polyester coated aluminum housing, and PRO-GUARD® probes. A very important feature of this series is the ability to ignore the effect of coatings that can adhere to the sensing probe. In most applications, a certain amount of the material being sensed will adhere to the sensing probe after a period of time. This can be due to the nature of the material itself or to condensed moisture that can cause dry material to bond to the probe's surface. Bindicator's PRO-GUARD® disregards the effects of probe coating and only indicates that material is present when the actual bulk of material (either dry or liquid) in the bin comes in contact with the probe.

Figure 2 shows the PRO-GUARD® probe. The drive current of PRO-GUARD® electrode is of the same frequency and polarity as that for the probe.

When a coating forms on the probe, the RF current from the PRO-GUARD® tends to saturate that portion of the built-up material near the wall so that little or no RF current can flow from the probe to the wall. When the actual bulk material in the bin fills to the point where it is touching the probe, current from the probe will flow around the saturated region and indicate material presence.

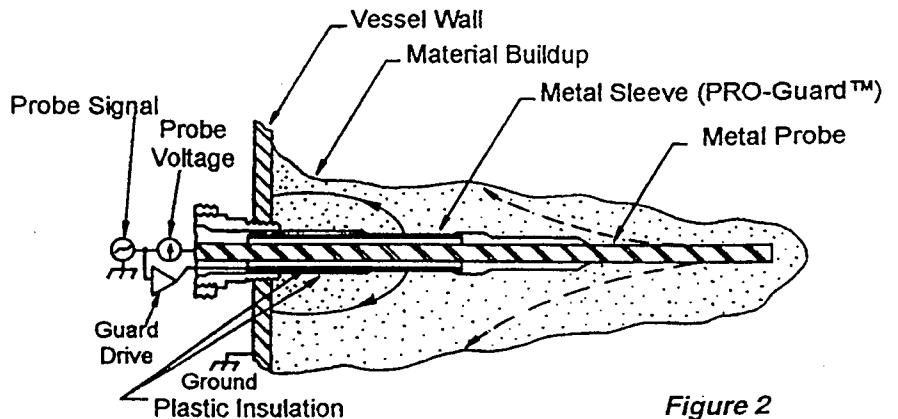

Figure 2

## 2.0 SPECIFICATIONS

### 2.1 *Electronics*

Line Voltage: 120VAC  $\pm$  15%, 240VAC  $\pm$  15%, 50/60 Hz,  
24VDC  $\pm$  4VDC, 12VDC  $\pm$  4VDC  
Power: 4 Watts  
Output Relay: DP/DT, 5 amps at 120VAC  
Temperature Range: -40° F to +160° F (-40C to +71°C) Medium & Low Sensitivity Setting  
-20° F to + 125° F (-20°C to + 50°C) High Sensitivity Setting  
Sensitivity Settings: 2 through 11 Picofarad - "0" Electronics  
1 through 11 Picofarad - "A" Electronics  
Time Delay: 1, 7, 14 Seconds (Selectable)  
Calibration: Manual - Field Adjustable

### 2.2 *Standard Duty Probe*

Dimensions: See Installation Drawing  
Mounting: 3/4" NPT - 316 SS or 1 1/4" NPT aluminum  
**\*\* For liquid service use the 3/4" NPT 316 SS thread for proper seal.  
1 1/4" NPT aluminum may be used for dry materials.**

Probe Materials: 316 SS and Ryton  
Pressure: 150 psi \*\* (10.5 kgs/cm<sup>2</sup>) (3/4" NPT fitting only)  
Probe Temperature: The 316 SS and Ryton probe is rated from -100°F to + 450F  
(-73°C to +232°C) *However, it is recommended that application temperatures be limited to +160° F. (71°C) maximum as dictated by the temperature rating of the electronics. If a higher temperature rating is required at the application, please consult factory.*

• Registered trademark of Phillips Chemical Co., Subsidiary of Phillips Petroleum

### 2.3 *Food Grade (Polysulfone) Probe with Threaded Connector*

Dimensions: See Installation Drawing  
Mounting: 3/4" NPT 316 SS or 1-1/4" NPT Aluminum  
**\*\*For liquid service use the 3/4"NPT 316 SS thread for proper seal.  
1-1/4"NPT aluminum may be used for dry materials.**

Probe Materials: 316 SS and Polysulfone  
Pressure: 150 psi\*\* (10.5 kgs/cm<sup>2</sup>)  
Probe Temperature: -30°F to + 300°F (-34°C to + 149°C) *However, it is recommended that application temperatures be limited to + 160°F (71°C) maximum as dictated by the temperature rating of the electronics. If a higher temperature rating is required at the application, please consult factory.*

### 2.4 *Stub Probe*

Dimensions: See Installation Drawing  
Mounting: 3/4"NPT 316 SS or 1-1/4" aluminum  
**\*\*For liquid service use the 3/4"NPT 316 SS thread for proper seal.  
1-1/4"NPT aluminum may be used for dry materials.**

Probe Materials: 316 SS and Polysulfone  
Pressure: 150 psi\*\* (10.5 kgs/cm<sup>2</sup>)  
Probe Temperature: -30°F to + 300°F (-34°C to + 149°C)  
*However, it is recommended that application temperatures be limited to + 160°F (71°C) maximum as dictated by the temperature rating of the electronics. If a higher temperature rating is required at the application, please consult factory.*

Consult the factory when using in solid, dry materials where active probe length must be reduced or special configurations are required.

## 2.5 Heavy Duty Probe

Dimensions: See Installation Drawing  
Mounting: 3/4"NPT - 316 SS or 1-1/4"NPT aluminum

**••For liquid service use the 3/4"NPT 316 SS thread for proper seal.  
1-1/4"NPT aluminum may be used for dry materials.**

Probe Materials: 316 SS and Ryton®\*  
Pressure: 150 psi\*\* (10.5 kgs/cm<sup>2</sup>)  
Probe Temperature: -100°F to + 450°F (-73°C to + 232°C)  
*However, it is recommended that application temperatures be limited to + 160°F (71 ° C maximum as dictated by the temperature rating of the electronics. If a higher temperature rating is required at the application, please consult factory.*

## 2.6 Standard Duty - Kynar Coated Probe

Dimensions: See Installation Drawing  
Mounting: 3/4"NPT - Teflon Coated  
Probe Materials: 316 SS and Ryton Coated with Kynar  
Pressure: 50 psi (3.5 kgs/cm<sup>2</sup>)  
Probe Temperature: -100°F to + 250°F (-73°C to + 121°C)

*However, it is recommended that application temperatures be limited to + 160°F (71°C) maximum as dictated by the temperature rating of the electronics. If a higher temperature rating is required at the application, please consult factory.*

## 2.7 Heavy Duty - Kynar Coated Probe

Dimensions: See Installation Drawing  
Mounting: 3/4"NPT - Teflon Coated  
Probe Materials: 316 SS and Ryton Coated with Kynar  
Pressure: 50 psi (3.5 kgs/cm<sup>2</sup>)  
Probe Temperature: The 316 SS and Ryton probe is rated from -100°F to + 250°F (-73°C to + 121°C) *However, it is recommended that application temperatures be limited to + 160°F (71°C) maximum as dictated by the temperature rating of the electronics. If a higher temperature rating is required at the application, please consult the factory.*

## 2.8 Flush Probe

Dimensions: See Installation Drawing  
Mounting: See Installation Drawing  
Probe Materials: 316 SS and Epoxy  
Pressure: 50 psi (3.5 kgs/cm<sup>2</sup>)  
Probe Temperature: -30°F to + 200°F (-34°C to + 93°C) Continuous  
-30°F to + 250°F (-34°C to + 121°C) Intermittent  
*However, it is recommended that application temperatures be limited to + 160°F (71°C) maximum as dictated by the temperature rating of the electronics. If a higher temperature rating is required at the application, please consult the factory.*

\* Registered Trademark of DuPont

\*\* Registered Trademark of Pennwalt

## 2.9 Enclosure

Dimensions: See Installation Drawing  
Material: Aluminum with polyester coating  
Ratings: NEMA 4/5, 12 and NEMA 7/9

## **2.10 UL Listed Explosionproof**

Dimensions: See Installation Drawings

Various RF models are available which have been "Listed" as complete assemblies by Underwriters Laboratories for use in Class 1, Div. 1, Groups C & D and Class II, Div 1, Groups E, F, & G atmospheres.

To be listed by UL these units must contain special intrinsic safety barriers to limit the amount of energy on the probe itself in the event of a failure in the electronics. UL also requires a special assembly of the probe to the electronic housing. Because of this special probe seal, the Explosionproof Models are dimensionally different from the General Purpose Units.

**The same dimensional difference exists for Coated Standard, Food, Stub, and Coated Heavy Duty probes.** No dimensional difference exists in the Flush Probe units.

On explosionproof units, an approved conduit seal fitting must be installed within 18 inches of conduit opening.

### **CAUTION:**

When mounting explosionproof units, never adjust the orientation of the probe or probe housing by turning the housing section. This will break internal wires and permanently damage the probe.

For tightening units with threaded bin connections, the unit must be positioned by using a wrench on the bin connector. Wrench size required is 1-1/16" with open end.

For "Flush Mount" probe units, the position must be adjusted by removing the mounting bolts and moving the entire probe and housing.

## **3.0 INSTALLATION**

### **3.1 Location and Mounting**

The probe should be located out of the direct flow of material while the vessel is being filled. Protective shields or an offset mounting procedure may be required.

Mounting the probe in a nozzle or location where material bridges excessively may cause false indication. The probe should be mounted so material does not build up excessively on the PRO-GUARD® area of the probe. (See **Figure 1.**) If the probe is mounted in a nozzle or nipple, the PRO-GUARD® area must be inside the vessel.

Vertical mounting reduces bridging problems. If material to be sensed is of a nature where buildup will continue to grow on the probe, vertical mounting is necessary.

The RF-8200 unit, when mounted horizontally, should be positioned so the conduit opening is down.

### **CAUTION:**

***When mounting explosionproof units, never adjust the orientation of the probe or probe housing by turning the housing section. This will break internal wires and permanently damage the probe. For tightening units with threaded bin connections, the unit must be positioned by using a wrench on the bin connector. Wrench size required is 1-1/16" with open end. For "Flush Mount" probe units, the position must be adjusted by removing the mounting bolts and moving the entire probe and housing.***

### 3.2 Wiring

Field wiring should conform to the requirements of the National Electrical Code and any other agency or authority having jurisdiction over the installation.

Connect power wiring as per **Figure 3**. For 120VAC units connect hot and neutral on terminals as marked. Ground connection should be made to ground screw located on the lower housing near the conduit entry.

For 240VAC units, connect one hot lead to terminal marked "hot", the other to the terminal marked "Neutral". Connect ground wire to ground screw as mentioned above.

For 24VDC units, connect correct leads to terminals marked "+VDC" and "(-)".

For 12VDC units, connect correct leads to terminals marked "+VDC" and "(-)".

#### CAUTION:

*Use caution when preparing all wires for connection to the terminal block. Strip insulation a maximum of 1/4 inch or use insulated wire ferrules such as Altech 8969.0 or Altech 2206.0 to prevent shorting of conductors. Tighten screws in terminal block to 4 in/lbs.*

### 3.3 Fail-Safe Selection

The RF-8200 is shipped from the factory in the high level fail-safe condition.

**High Level Operation** - If the electrical power fails, the relay turns off.

This indicates material as if the tank were full.

Relay Light Logic

Red Relay Light **On** - no material present

Red Relay Light **Off** - material present

**Low Level Operation** - If the electrical power fails, the relay turns off. This indicates no material as if the tank were empty.

Relay Light Logic

Red Relay Light **On** - material present

Red Relay Light **Off** - no material present

**NOTE:** For Low Level Fail-safe operating condition, clip the bare wire "fail-safe" selection jumper (See **Figure 4** or **5** for location). The Green "Detection LED" is always off when material is present, and on when no material is present, regardless of fail-safe setting. The relay contact terminals are labeled in the powered, unalarmed state. This status may be opposite that of other brands of level controls. Contacts as marked on the terminals are not the relays nomenclature, but are marked so contacts are in "normal" positions when unit is powered and unalarmed.

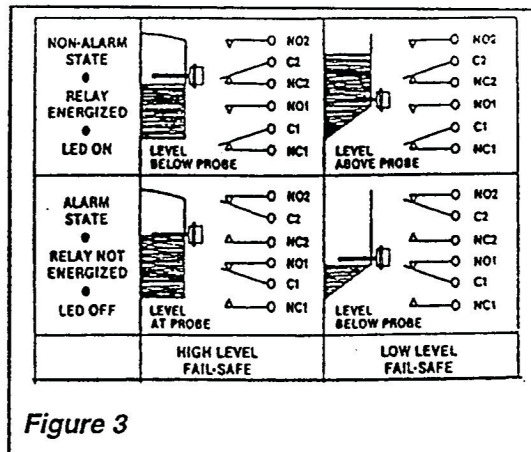

Figure 3

### 3.4 Time Delay Setting

The RF-8200 units are shipped from the factory in the minimum time delay position. See **Figure 4** or **5** for location and position setting. When used in liquid or agitated material where material movement could cause false or premature level indication, an increased time delay selection may be desirable.

Time delays are as follows:

Minimum Setting	1 second
Medium Setting	7 seconds
Maximum Setting	14 seconds

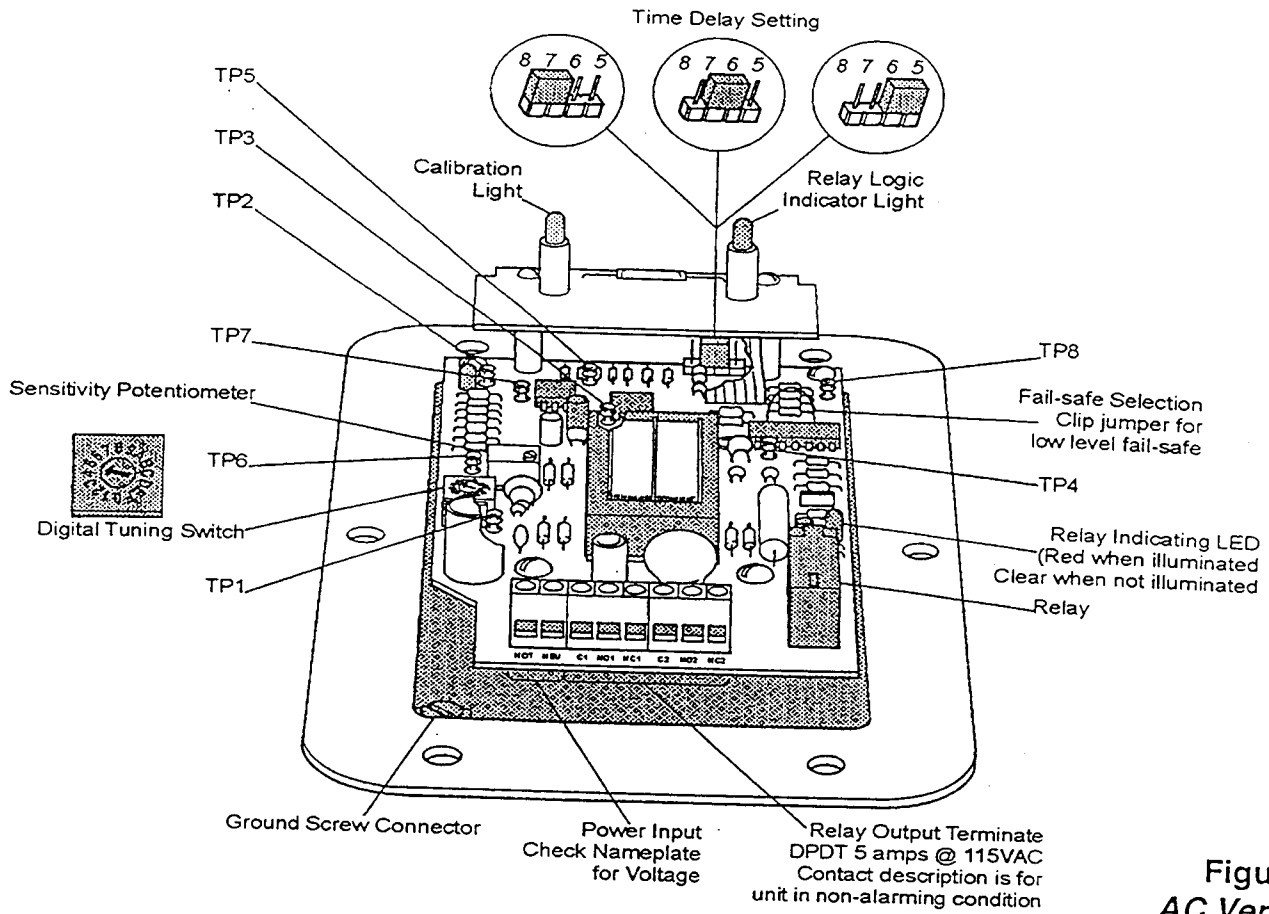

Figure 4  
AC Version

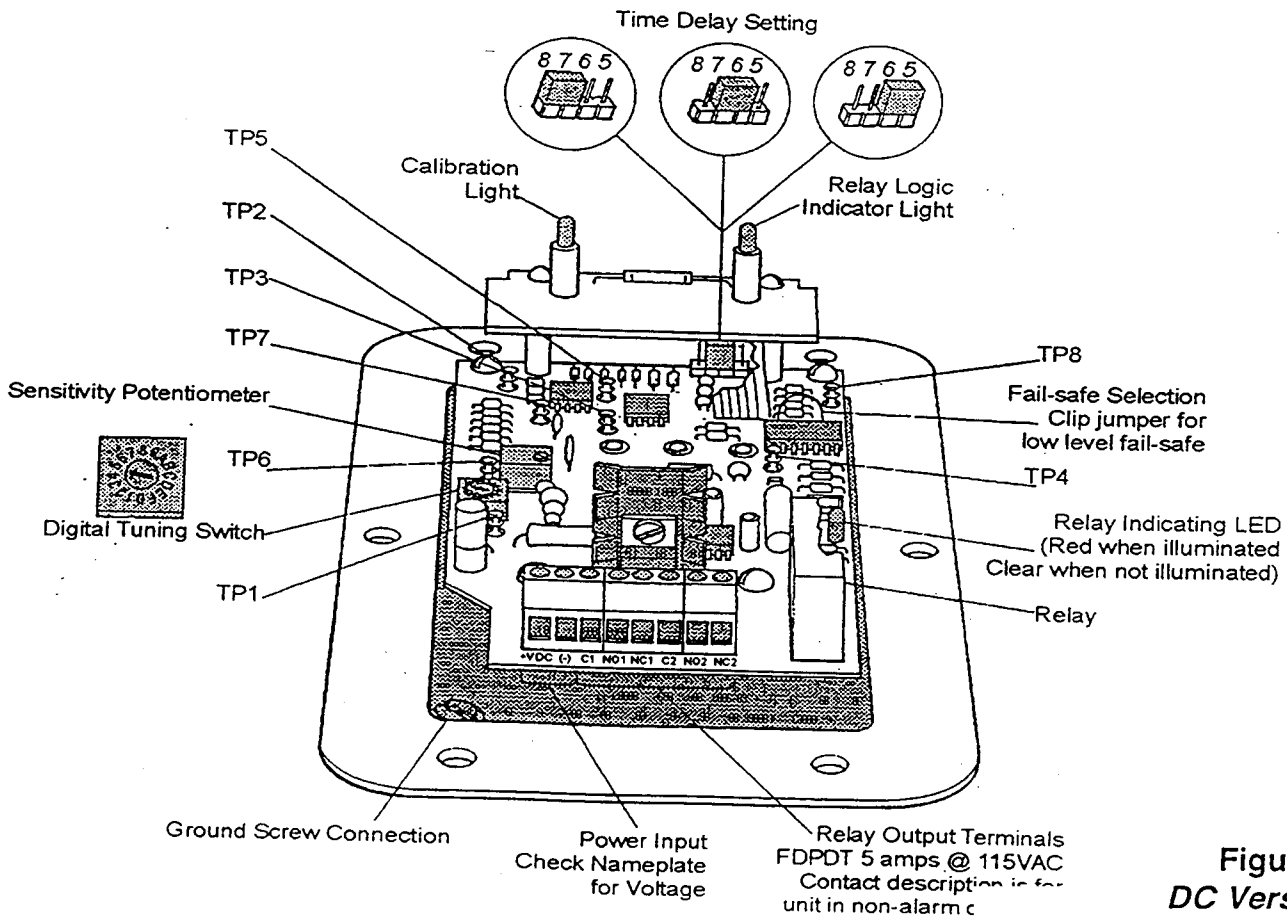

Figure 5  
DC Version



### 3.5 Calibration

The RF-8200 units are manufactured with adjustable calibration. Calibration is necessary since all installations are slightly different. Material build up on the probe, significant changes in ambient temperatures, and time may cause a need to Recalibrate a unit.

#### Preliminary Calibration Steps:

Before recalibrating the unit, the following conditions should exist:

- Unit is installed in vessel and material is well below the probe (3 ft. if possible).
- Equipment that may be started or stopped by the unit is locked out. The relay contacts of the RF unit will open and close during recalibration procedures. Remove the wiring from the relay output terminals if necessary.
- Input power to the unit is present.

#### Calibration Procedure:

1. Turn the "Sensitivity Potentiometer" 32 full turns clockwise (cw). See Figure 4 or 5.
2. Set the arrow of the Digital Tuning Switch (SW1) to "0" (zero). See Figure 4 or 5.
3. Turn the "Digital Tuning Switch" clockwise to a higher setting until the green detection indicating LED turns off.
4. Slowly turn the "Sensitivity Potentiometer" counterclockwise (ccw) until the green "Detection Indicating" LED just turns on.
5. Continue turning the "Sensitivity Potentiometer" counterclockwise (ccw) the following number of turns to adjust sensitivity.

One (1) more turn - "Very High (1pf) Sensitivity". Note: For special models only. This setting is for sensing very light, non-conductive materials.

Two and one-half (2-1/2) more turns - "High (2 pf) Sensitivity". This setting is for sensing light, non-conductive materials such as plastic pellets, light powders and dry grain.

Six (6) more turns - "Medium (5 pf) Sensitivity". This setting is for sensing moderately dense or non-conductive liquids such as cement, wet grain and petroleum products.

Fourteen (14) more turns - "Low (11 pf) Sensitivity". This setting is for sensing most aqueous liquid solutions or conductive materials.

### 3.6 Verification

Raise and lower material level and observe relay indicating LED for verification of proper operating condition. If the unit fails to detect the material, a higher sensitivity setting may be needed. If the unit falsely indicates material presence, a lower sensitivity setting may be needed.

### 3.7 Function Test

The "Function Test" option appears on units with a model code of 2 in the fourth digit. (Example: RF82C0G1A. These models can also be identified by a second circuit board. (See Figure 4 or 5)

Placing the fob in the test position as indicated below will initiate a test of the unit. This test is only practical when material level is below the probe.

If the unit is in calibration and capable of sensing the material at the probe, the output relay will go into the alarm state and the Red LED will illuminate when the fob is placed in the test position.

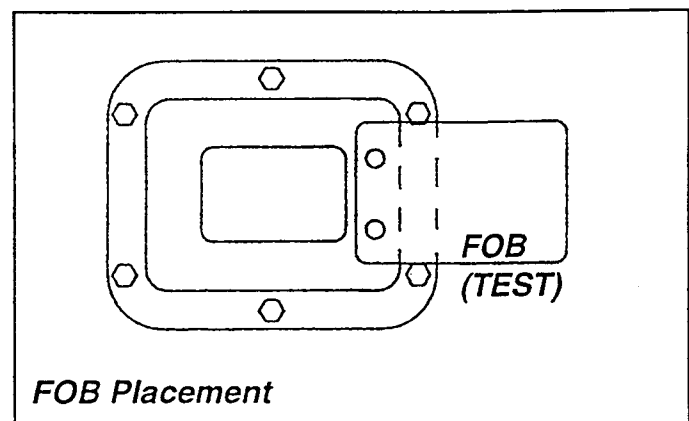

## **4.0 APPLICATION CONSIDERATIONS**

### **4.1 Installation Errors**

The probe should be located out of the direct flow of material while the vessel is being filled.

The unit should be mounted with the conduit opening down and located, if possible, higher than the conduit raceway. This will eliminate the possibility of moisture settling in the RF-8000 unit. If conduit is higher than the unit, provide a conduit loop; under the unit with a conduit drain fitting.

Mounting the probe in a nozzle or location where material bridges excessively may cause false indication. The unit should be mounted so material does not build up excessively over the PRO-GUARD® area of the probe. See **Figure 1**. If the unit is mounted in a nozzle or nipple, the PRO-GUARD® area must be inside the vessel.

Vertical mounting reduces bridging problems. If material to be sensed is of a nature where a buildup will continue to grow on the probe, vertical mounting is necessary.

### **4.2 Application Errors**

RF-8000 units have manual calibration and PRO-GUARD® at the probe. They are designed for use in a wide range of free flowing materials. Application considerations for the RF-8000 are as follows:

#### **4.2.1. Extreme Material Buildup**

Avoid using it in materials where a continual buildup of a conductive material occurs. The PRO-GUARD® will prevent false indication from material coating and condensation, but a continual, increased buildup will eventually exceed the PRO-GUARD® capability.

Selecting a lower sensitivity setting on the RF-8200 may suffice in borderline applications.

#### **4.2.2. High Vibration**

Use in vessels and bins with vibrators or other considerable vibration should be avoided. If your application does involve vibration, consider the RF-10000 with remote electronics or the "Potted" electronic option.

#### **4.2.3. High Temperature**

The use of the RF-8200 in areas where the housing is subject to ambient temperatures exceeding + 160°F should be avoided. Consider the RF-10000 with remote electronics if your application does involve elevated ambient temperatures.

#### **4.2.4. Highly Corrosive Materials**

Wetted probe parts consist of 316 SS and Ryton®. The 1 1/4"NPT mounting connection and enclosure are constructed in aluminum with a polyester coating. If you believe the materials in contact with the probe or mounting may cause corrosion with aluminum, insulation materials, or 316 SS, consult the factory.

#### **4.2.5. Extremely Light and Dry Materials**

Use in very light materials (less than 30lbs/cu ft) and very dry, non-conductive materials (less than 3% moisture) should be avoided with the standard RF-8200 unit. Special sensitivity units may be applicable, or the use of the RF-9000 Series units with sensitivity attachments advisable.

Contact our Application Engineers for further guidance.

## 5.0 TROUBLESHOOTING

### 5.1 RF8200 Electronics Troubleshooting using a Voltmeter

#### PRELIMINARY

1. Check wiring for proper connections, grounding and voltage.
2. Ensure unit is mounted out of the flow of material.
3. Unit should have been calibrated with material at least 2 feet below the probe.
4. Visually inspect the probe for cracks or abnormalities.

#### CALIBRATING WITH A VOLTMETER

1. Set the voltmeter to 2 volts DC.
2. Locate TEST POINTS TP6 and TP7 on circuit board (see *Figure 4 or 5* in this manual).
3. Connect voltmeter (+) to TP7 and (-) to TP6
4. With the unit calibrated to "HIGH" sensitivity (2-1/2 turns), and the bin empty the voltage should be approximately 0.110 volts.
5. When material contacts the probe, voltage will decrease (negative) until the unit alarms. The voltage will continue to decrease as material covers the probe.

#### TYPICAL CALIBRATION VALUE

1. The unit calibration should be adjusted so that an alarm condition will cause a decrease in voltage of approximately 50 % in the negative direction.

#### **EXAMPLE:**

50% of 0.110 volts = 0.055 volts

Alarm voltage with probe covered should be 0.055 volts in the negative direction, or

**Alarm voltage = -0.055 volts**

2. If the alarm voltage value does not conform to this percent change, it is likely that the selected calibration value is incorrect. Recalibrate the unit if necessary (see SECTION 4.0 CALIBRATION and SETTINGS in this manual).

### 5.2 RF8200 Probe Troubleshooting using a Ohmmeter

1. The probe can also be tested using an ohmmeter (continuity).
2. Disconnect the power and remove the electronic circuit board.
- 3.. Test for continuity between all wire combinations (RED-BLUE-GREEN) resistance value should be near infinity or open (general purpose units only).
4. Make sure that all connections of fork terminals to wires are secure, and that local wire connections are correct as follows:

**RED = ACTIVE (Probe)**

**BLUE = (Guard)**

**GREEN = GROUND (Chassis/Earth)**

5. If attempts to locate any difficulties with the unit fail, notify your local representative or BINDICATOR. To help solve your problem quickly, please have as much of the following information as possible:
  - Model number
  - Date purchased
  - Brief application information such as: material to be detected, approximate vessel size and location of unit(s) in the vessel
  - Brief description of the problem such as: fails to detect material or intermittent false alarms.

**NOTE:** Equipment shipped back to the factory without proper authorization, will be refused and returned at the shipper's expense.

### 5.3 Factory Assistance

If attempts to locate any difficulties with the unit fail, notify your local representative. To help solve your problem quickly, please have as much of the following information as possible:

- Model Number
- Date purchased
- Brief application information such as: material to be detected, approximate vessel size and location of unit(s) in the vessel.
- Brief description of the problem such as: fails to detect material or intermittent false alarms.

If your local representative is unable to determine the cause of your difficulty, they will refer you to a factory engineer. **Equipment shipped back to the factory without proper authorization, will be refused and returned at the shipper's expense.**

## 6.0 WARRANTY AND PARTS

### 6.1 Warranty

Refer to Manufacturer's General Terms and Conditions of Sale for warranty information.

The RF-8200 is designed to give years of unattended service. No scheduled maintenance or parts service is required.

### 6.2 Electronics Replacement

**NOTE:** Refer to *Figure 6* when replacing electronic circuit board.

#### **CAUTION:**

**Disconnect input power from its source before attempting to remove the electronic assembly. Follow proper lock-out procedures after turning off the power.**

<u>Product Code</u>	<u>Description</u>
LRF110910	EU/82 120VAC w/external LED/Test (2pf)
LRF110912	EU/82 240VAC w/external LED/Test (2pf)
LRF110915	EU/82 120VAC w/external LED/Test (1pf)
LRF110916	EU/82 240VAC w/external LED/Test (1pf)
LRF110917	EU/82 24VDC w/external LED/Test (2pf)
LRF109918	EU/82 24VDC w/external LED/Test (1pf)
LRF110919	EU/82 12VDC w/external LED/Test (2pf)

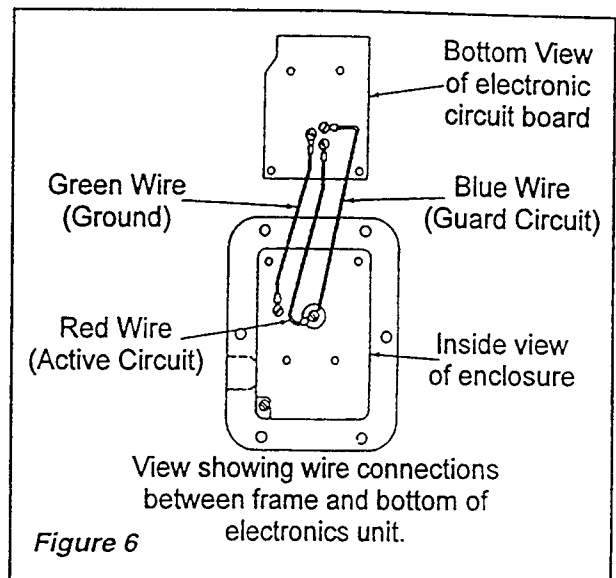

## 7.0 DRAWINGS (in the following order at the back of this manual)

<u>Drawing Number</u>	<u>Description</u>
B-LRF1E0095	RF-8000/8200 Installation & Hook-up Integral Mount - VAC
B-LRF1E0159	RF-8000/8200 Installation & Hook-up Integral Mount - VDC
B-LRF180131	RF-9100/9200/8200 UL Dimensional Drawing
B-LRF180120	RF-9100/9200/8200 UL Explosionproof Dimensional Drawing
B-LRF180122	RF-9100/9200/8200 General Purpose with Type "S" Mounting
B-LRF180119	RF-9100/9200/8200 General Purpose with Type "N" Mounting
B-LRF180121	RF-9100/9200/8200 UL Explosionproof with Type "S" Mounting
B-LRF180123	RF-9100/9200/8200 Flush Probe General Purpose and Explosionproof
B-LRF180169	RF-8200 General Purpose Stub Probe with Type "A" & "N" Mounting

8.0 **MODEL SELECTION**

Shipping Weight: 9 Lbs.

**RF-8200 INTEGRAL UNIT**

RF82 - - - - - (See Note 2 Below)

**Assembly Configuration**

- A = 3/4" S.S. & 1 1/4" Aluminum & Flush Mount
- S = Sanitary Fitting
- N = 1 1/4" Alum. Only (NEMA 4 Only)

**Voltage**

- 1 = 120VAC
- 2 = 240VAC
- 3 = 24VDC
- 4 = 12VDC
- 5 = 24VAC
- 6 = 48VAC

**Enclosure Type**

- G = General Purpose NEMA 4/5.
- X = Explosionproof NEMA 7/9 - UL Listed /C-UL Listed (\*See Note 1 Below)
- D = Dust Ignitionproof for "J" Probe Only

**Probe Type**

- 0 = Standard
- 1 = Standard, Kynar® Coated.
- 2 = Food Grade
- 4 = Stub.
- 5 = Heavy Duty.
- 6 = Heavy Duty Kynar® Coated.
- 8 = Flush (Use "A" Configuration Only).
- A = Armored Food Grade
- J = Jumbo Probe

**Electronics with display board and function test**

- C = Standard (2pf) with Function Test (see comment)
- D = Sensitivity Modification (1pf) with Function Test (see comment)

**RF-8200 Radio Frequency Type Series**

Note 1: For use with assembly configurations "A" or "S" only. \*Approval pending

Note 2: For **3A Sanitary Certification**, add "3A" at end of the Model Code.  
Configuration "S" must be used and either "Type 2" Food Grade probe or "Type 4" Stub probe.

The probe is rated -100°F. to +450°F., however, it is recommended that application temperatures for the RF-8200 be limited to +160°F. as indicated by the temperature rating of the electronics.

If a higher temperature rating is required, please consult the factory.

REVISIONS	DATE	CK'D	APP'D
A	RF7000 HOOKUP DIAGRAM ADDED	ES	SG
B	GRD. WIRE NOTE ADDED EOB BY 6014	RE	RE
C	TYPE "N" MOUNTING ADDED TO DWG.	RE	RE
D	NON HOOKUP FOR RF8000 AND RF8100 PER PROJECT H A-1503	RE	RE

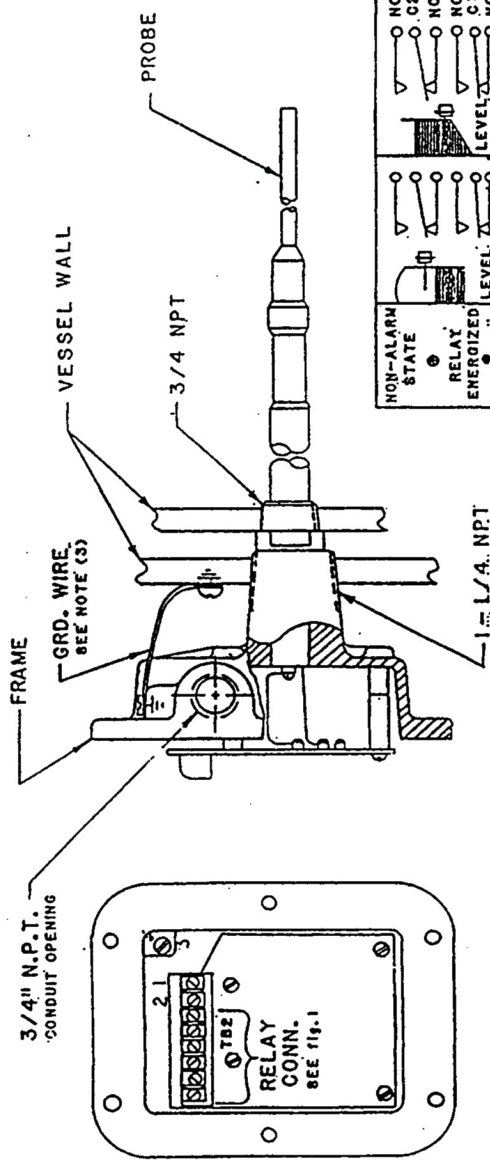

RF8000 (TYPE "A" MOUNTING)

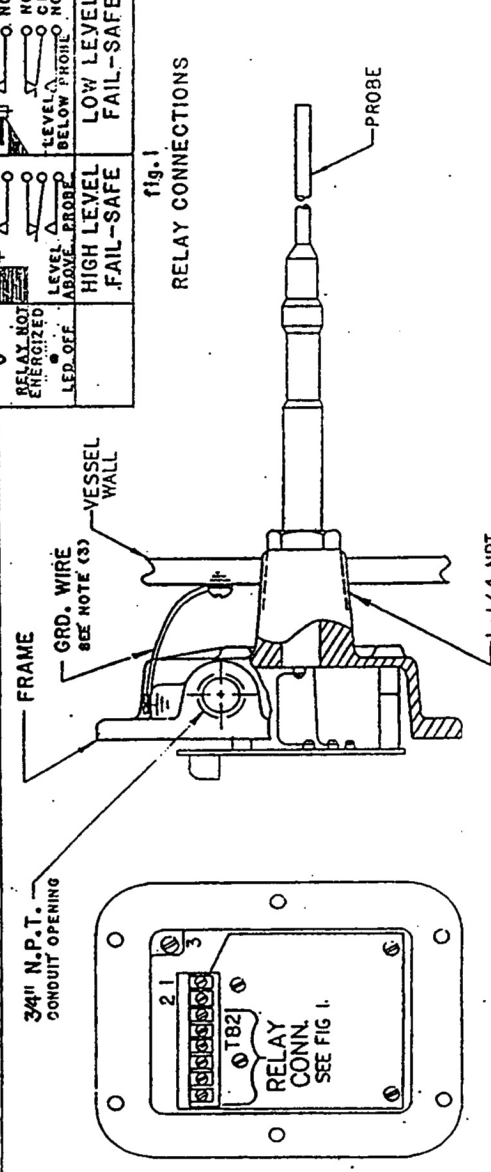

RF8000 (TYPE "N" MOUNTING)

NON-ALARM STATE	RELAY ENERGIZED LED ON	ALARM STATE	RELAY ENERGIZED LED OFF
LEVEL BELOW PROBE	LEVEL ABOVE PROBE	LEVEL ABOVE PROBE	LEVEL BELOW PROBE
LOW LEVEL FAIL-SAFE	HIGH LEVEL FAIL-SAFE	HIGH LEVEL FAIL-SAFE	LOW LEVEL FAIL-SAFE

fig. 1

RELAY CONNECTIONS

- NOTE:
- 1) FIELD WIRING SHALL BE ACCORDING TO LOCAL STDS.
  - 2) POWER TO UNITS (TB2) 18 AWG MINIMUM RECOMMENDED.  
1 - HOT  
2 - NEU
  - 3) GRD TO FRAME SCREW  
PREFERRED METHOD OF GROUNDING  
RF UNIT TO VESSEL WALL.

DO NOT SCALE DIMENSIONS ARE IN INCHES

DET.	REQ'D. SHT.	DESCRIPTION	MAT. OR PART
UNSPECIFIED TOL. DECIMALS: XX.XX	DRAWN S. DOEHM	CHECKED	APPROVED
ANGLES: 1/16" MAX ON EDGES AND	DATE 26 MAY 87	DATE	DATE
	SCALE	SIZE	ANT OR DRAWING
		B	LRELE0095
			PREVIOUS

BINDICATOR®  
PORT HURON, MICHIGAN 48060

TITLE INSTALLATION & HOOK-UP RF8000/8100  
... INT'FCAL., MOUNT\_VAC

REF.

A	REVISIONS	DATE	CK'D	APP'D
	NOW HOOKUP FOR RF800 AND RF8300 PER PROJECT # A-9503	10/14/85	AC	<i>[Signature]</i>

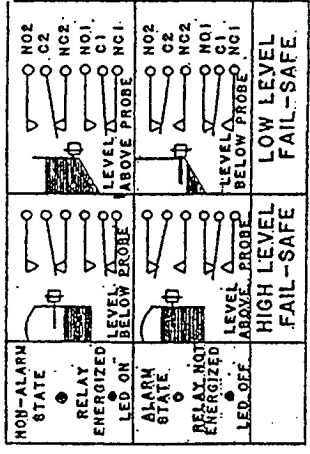
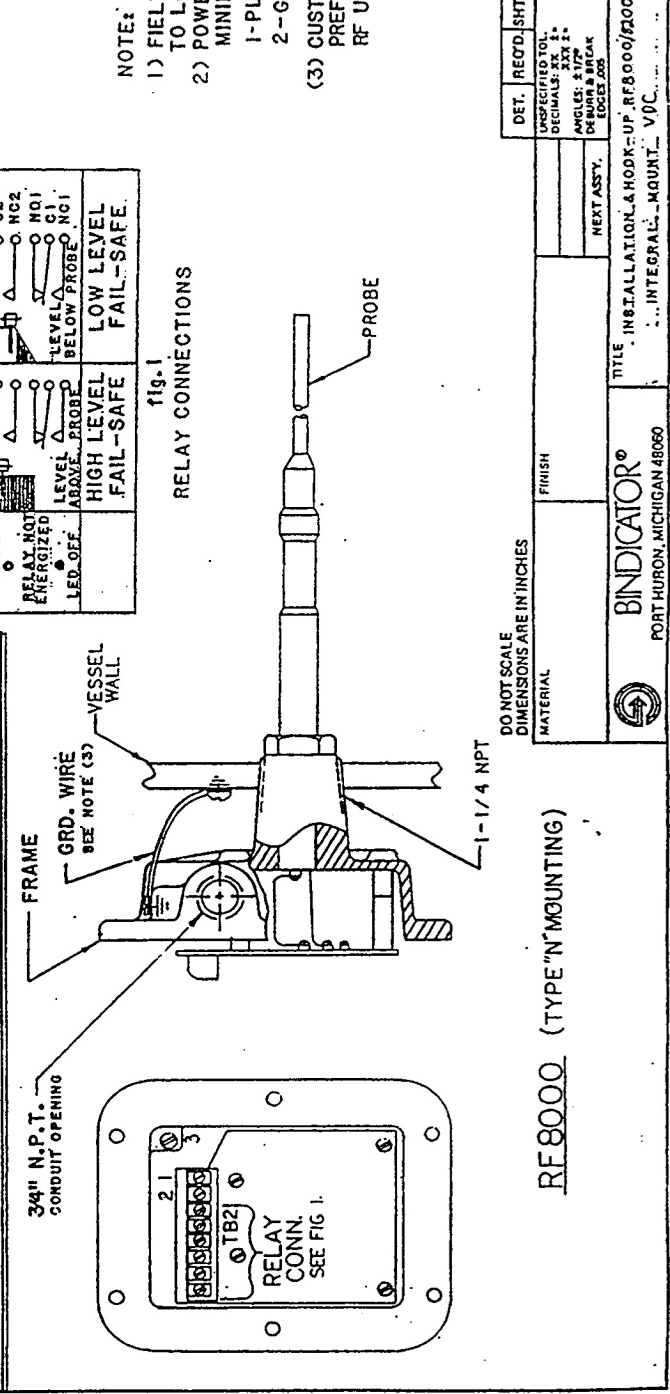
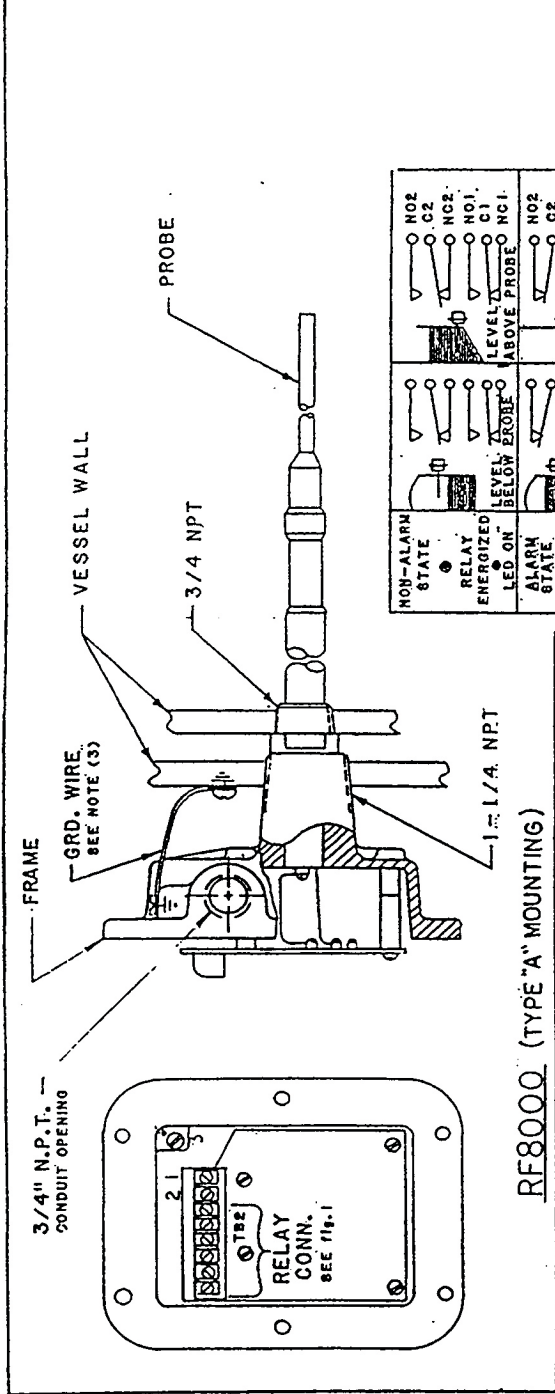

- NOTE:
- 1) FIELD WIRING SHALL BE ACCORDING TO LOCAL STDS.
  - 2) POWER TO UNITS (TB2) 18 AWG MINIMUM RECOMMENDED.  
1-PLUS VDC  
2-GRD
  - (3) CUSTOMER PROVIDED GRD. WIRE. PREFERRED METHOD OF GROUNDING RE UNIT TO VESSEL WALL.

DO NOT SCALE DIMENSIONS ARE IN INCHES		MATERIAL		FINISH		DESCRIPTION		MAT. OR PART	
DET. RECD. SHIT.		UNSPECIFIED TOL. DECIMALS: XX 1/2 ANGLES: XX 1/2 DE BURR & BREAK EDGES 200		DRAWN NEAL		CHECKED [Signature]		APPROVED [Signature]	
NEXT ASSTY.		DATE 12-12-89		DATE 12-12-89		DATE 12-2-89		DATE 12-2-89	
TITLE		SCALE		PART OR DRAWING		PREVIOUS		REF.	
BINDERATOR®		1:1		B		LRELE0159		REF.	
PORT HURON, MICHIGAN 48060		INTEGRAL MOUNT VDC		INTEGRAL MOUNT VDC		INTEGRAL MOUNT VDC		INTEGRAL MOUNT VDC	

REVISIONS		DATE	BY	CHKD	APP'D
A	SPELLING ERROR	1 1/4'	TR	10/18/93	JN RB
B	ADD OUTLINE FOR RF8200 PER PROJECT#A-9503	3/4'	AC	10/20/95	P

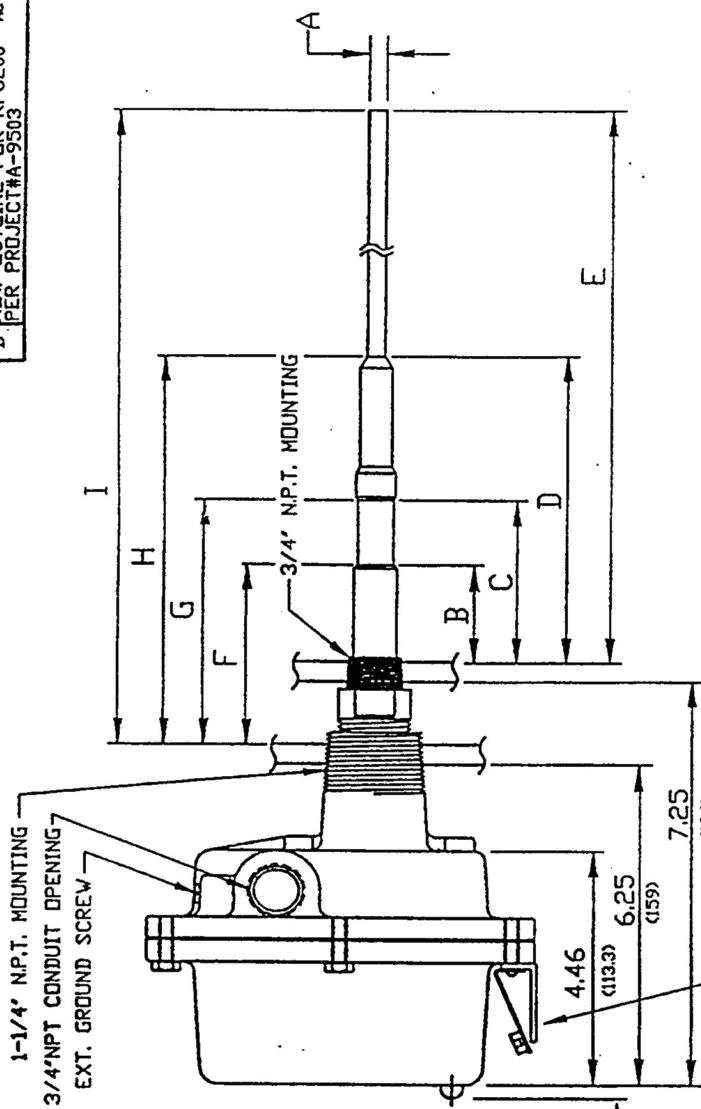

APPROX DIM'S	RED L.E.D. (ALARM)	GREEN L.E.D. (CALIBRATION)	STUB	FINISH
I	15.25 (387.5)	15.63 (396.7)	15.63 (396.7)	15.25 (387.5)
H	7.00 (178)	7.00 (178)	7.00 (178)	7.00 (178)
G	4.50 (114.3)	4.50 (114.3)	4.50 (114.3)	4.50 (114.3)
F	3.38 (86)	3.38 (86)	3.38 (86)	3.38 (86)
E	14.25 (363.2)	14.62 (371.4)	14.62 (371.4)	14.25 (363.2)
D	6.00 (152.5)	6.00 (152.5)	6.00 (152.5)	6.00 (152.5)
C	3.50 (89)	3.50 (89)	3.50 (89)	3.50 (89)
B	2.38 (60.5)	2.38 (60.5)	2.38 (60.5)	2.38 (60.5)
A	.31 DIA. (7.9)	.31 DIA. (7.9)	.31 DIA. (7.9)	.31 DIA. (7.9)
STUB	H.D. COATED	H.D. COATED	H.D. COATED	H.D. COATED
STUB	STUB	STUB	STUB	STUB

SPRING & MAGNET ASSY FOR RF-9100 ONLY

DO NOT SCALE DIM'S. ARE IN INCHES  
BRAKTED. DIM'S ARE IN MM.

DET. RECD/SHI	DESCRIPTION	MAT. OR PART
UNRECORDED TO RECORD	ISSUED	PROJ.
NO. OF CHANGES	REVISED	NO.
DATE	DATE	DATE
9/11/93	9/13/93	9/13/93
SCALE	SIZE	SCALE
NONE	B	LRF180131

TITLE MANUAL DRAWING  
RF 9100/9200/8200 UL

BINDICATOR®  
PORT HURON, MICHIGAN 48060



REVISIONS		DATE	BY
REDRAWN ON CAD			
A	SPELLING ERROR, TIGHTENING WAS TIGHTENING.	11/12/92	JN RB
B	NEW OUTLINE FOR RF8200 PER PROJECT#A-9503	10/25/92	AC

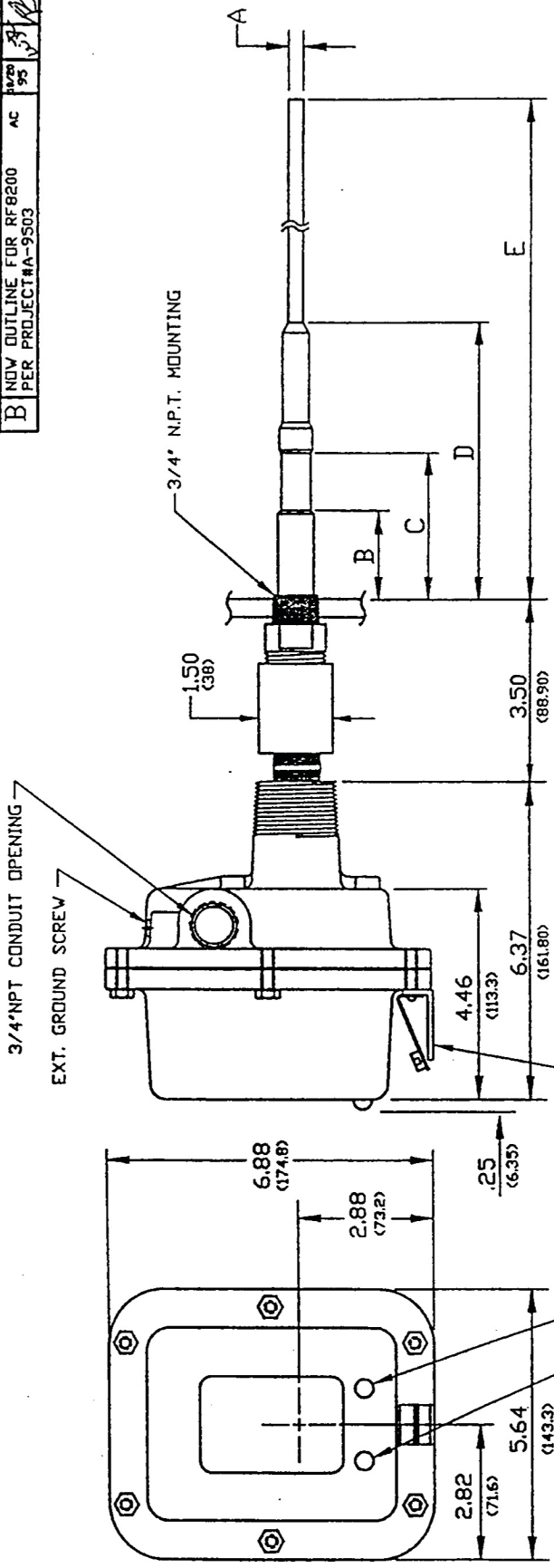

**'CAUTION'**  
 WHEN MOUNTING EXPLOSION PROOF UNITS, NEVER ADJUST THE ORIENTATION OF THE PROBE OR PROBE HOUSING BY TURNING THE HOUSING SECTION. THIS WILL BREAK INTERNAL WIRES AND PERMANENTLY DAMAGE THE PROBE.  
 FOR TIGHTENING UNITS WITH THREADED BIN CONNECTIONS, THE UNIT MUST BE POSITIONED BY USING A WRENCH ON THE BIN CONNECTOR. WRENCH SIZE REQUIRED IS 1-1/16 INCH OPEN END.

DO NOT SCALE DIM'S. ARE IN INCHES  
 BRACKETED DIM'S ARE IN MM.

APPROX DIM'S	STD. FOODGRADE	STD. KYNAR COATED	H.D. COATED	STUB
E	14.25 (362)	18.25 (463.5)	14.62 (371.4)	18.62 (472.95)
D	6.00 (152.5)	10.75 (273)	6.00 (152.5)	10.75 (273)
C	3.50 (89)	9.00 (228.5)	3.50 (89)	9.00 (228.5)
B	2.38 (60.5)	7.50 (190.5)	2.38 (60.5)	7.50 (190.5)
A	.31 DIA. (8)	.38 DIA. (9.5)	.31 DIA. (8)	.31 DIA. (8)

DET.	READSHT	DESCRIPTION	MAJOR PART
UNDESIGNED TO	DESIGNED BY	APPROVED	PROD.
DESIGNED BY	LANGOLF RANDY	RZ	RB
DATE	4/25/92	DATE	4/27/92
SCALE	NDNE	SCALE	NDNE
TITLE		PART OR DRAWING	
MANUAL DRAWING		LRF180120	
RF 9100/9200/8200 UL X/P			

**BINDICATOR®**  
 PORT HURON, MICHIGAN 48060

REVISIONS		DATE	BY	APP'D
A	SPELLING ERROR, CUSTOMER WAS COSTUMER	1/18/93	TB	RB
B	NOW OUTLINE FOR RF8200 PER PROJECT#A-9503	10/24/95	JN	RB

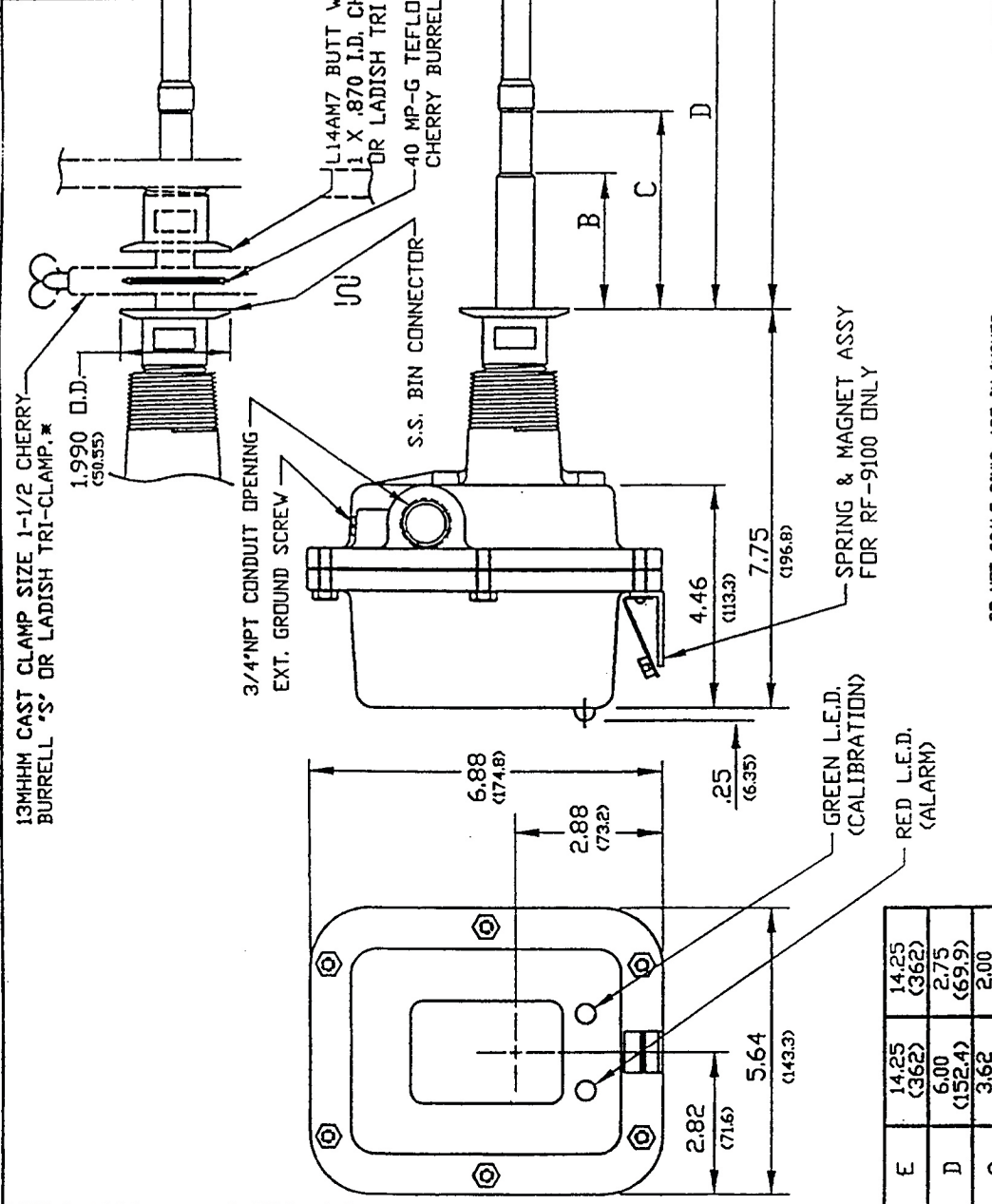

DET.	REQ'D	SHIT	DESCRIPTION	MAT.	DR	PART
DESIGNED BY	LANGOLF	APPROVED	RZ	PROG.	RB	
DATE	4/25/92	DATE	4/27/92	DATE	4/27/92	
SCALE	NONE	SCALE	B	PART OR DRAWING	LRF180122	

APPROX DIM'S	FOODGRADE	STUB
E	14.25 (362)	14.25 (362)
D	6.00 (152.4)	2.75 (69.9)
C	3.62 (91.95)	2.00 (50.8)
B	2.38 (61.5)	1.50 (38)
A	.31 DIA. (8)	.31 DIA. (8)

BINDERATOR®		TITLE
PDRT HURONMICHIGAN 48060	RF9100/9200/8200 G/P, TYPE 'S' MOUNTING	MANUAL DRAWING

\* CUSTOMER SUPPLIED

DO NOT SCALE DIM'S. ARE IN INCHES  
BRACKETED, DIM'S ARE IN MM.

REVISIONS		DATE	BY
A	NEW OUTLINE FOR RF8200 PER PROJECT #A-9503	10/28/92	[Signature]

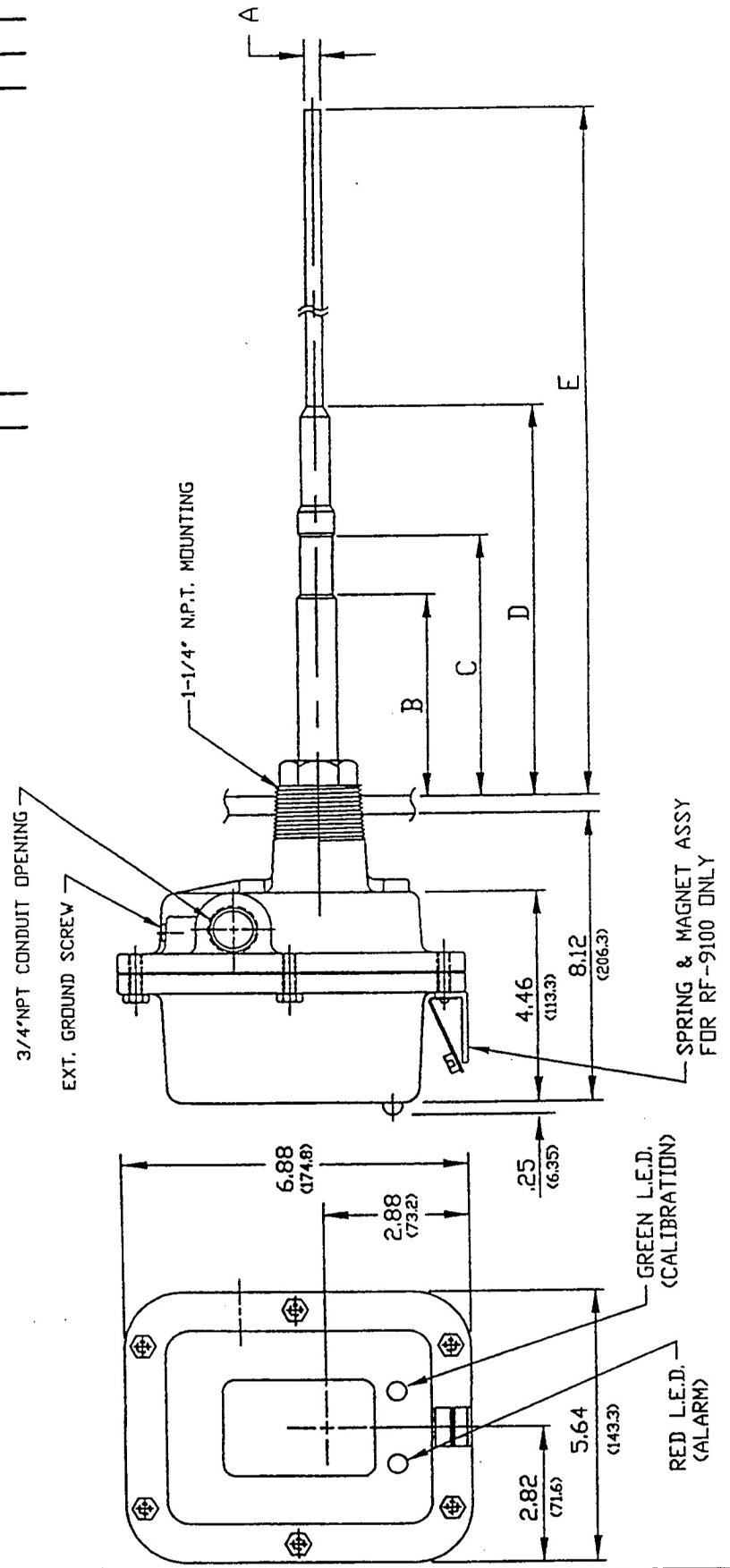

APPROX DIM'S	STD. & FOODGRADE	H.D.	STD. KYNAR COATED	H.D. KYNAR COATED
E	15.25 (387.5)	19.25 (489)	15.62 (396.7)	19.62 (498.35)
D	7.00 (178)	11.75 (298.5)	7.00 (178)	11.75 (298.5)
C	4.50 (114.5)	10.00 (254)	4.50 (114.5)	10.00 (254)
B	3.38 (86)	8.5 (216)	3.38 (86)	8.5 (216)
A	.31 DIA. (8)	.38 DIA. (9.5)	.31 DIA. (8)	.38 DIA. (9.5)

DO NOT SCALE DIMS. ARE IN INCHES  
BRAKTTED. DIM'S ARE IN MM.

DET. REQDSHT	DESCRIPTION	MATERIAL
DESIGNED BY: LANGOLF	CHECKED BY: RANDY	PROJ: RB
DRAWN BY: LANGOLF	APPROVED BY: RZ	DATE: 4/27/92
DATE: 4/24/92	DATE: 4/27/92	DATE: 4/27/92
SCALE: NONE	SCALE: NONE	SCALE: NONE
SIZE: B	SIZE: B	SIZE: B
PART OR DRAWING: LRF180119		

TITLE: MANUAL DRAWING  
 PORT HURON/MICHIGAN 48060 RF9100/9200/8200 G/P, TYPE 'N' MOUNTING



REVISIONS		DATE	BY	APP'D
A	SPELLING ERROR, TIGHTENING WAS TIGHTING.	93	JN	RB
B	NEW OUTLINE FOR RF8200 PER PROJECT#A-9503	95	AC	RB

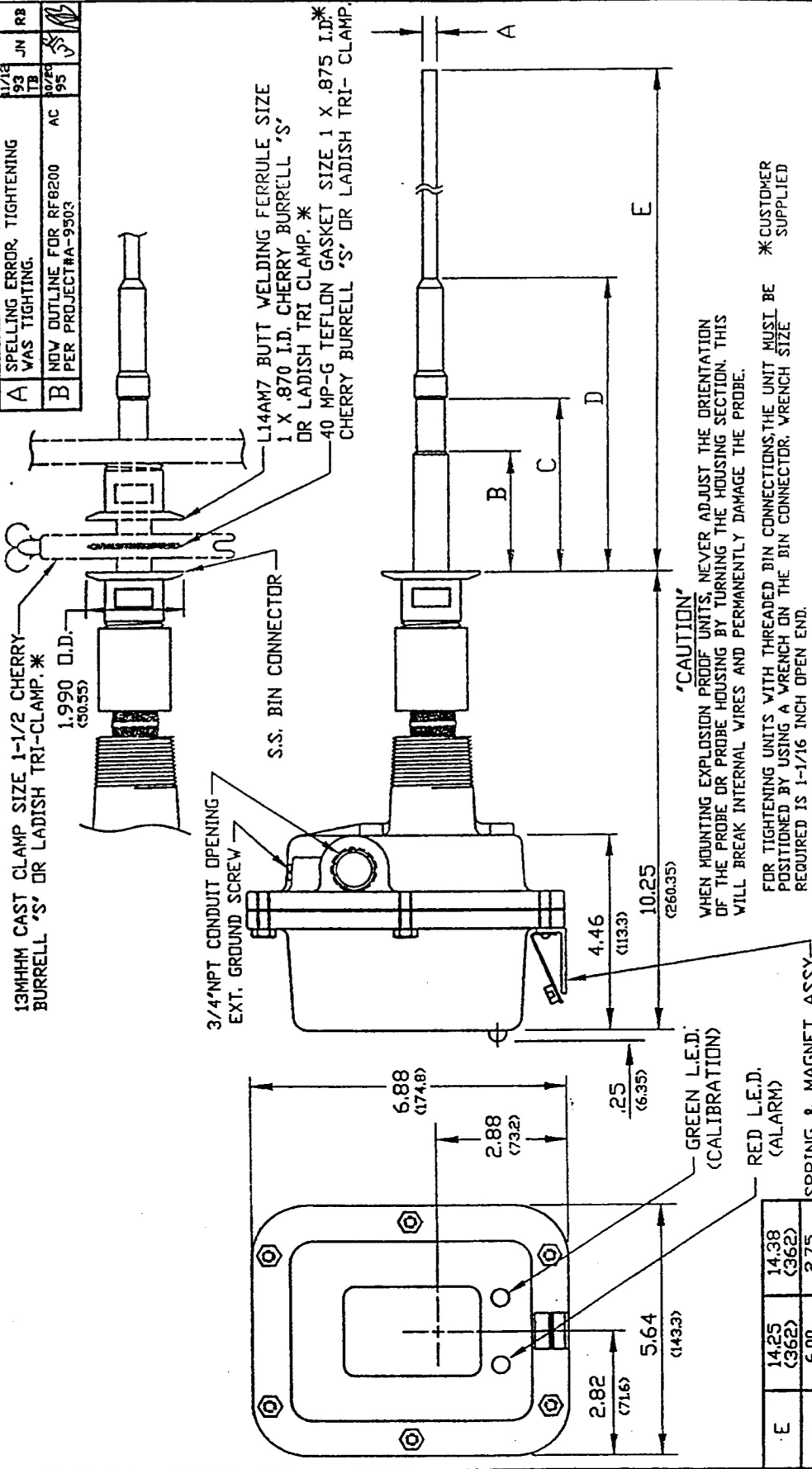

DET. REQ'D	DESCRIPTION	MATERIAL	PART
DESIGNED BY JANUARY 93 LANGOLF	CHECKED RANDY RZ	FINISH	PROD. RB
APPROVED BY JANUARY 93 LANGOLF	DATE 4/27/92	SCALE NONE	DATE 4/27/92
DESIGNED BY JANUARY 95 LANGOLF	DATE 4/27/92	SCALE NONE	DATE 4/27/92
APPROVED BY JANUARY 95 LANGOLF	DATE 4/27/92	SCALE NONE	DATE 4/27/92
TITLE RF9100/9200/8200 UL X/P, TYPE 'S' MOUNTING		PART OR DRAWING LRF180121	

APPROX DIM'S	FOODGRADE	STUB
E	14.25 (362)	14.38 (362)
D	6.00 (152.5)	2.75 (69.9)
C	3.62 (91.95)	2.00 (50.8)
B	2.38 (60.5)	1.50 (38.1)
A	.31 DIA. (8)	.31 DIA. (8)

REVISIONS		DATE	BY
—	REDRAWN ON CAD	10/28/93	VP
A	INDOW OUTLINE FOR RF8200 PER PROJECT #A-9503 AC		

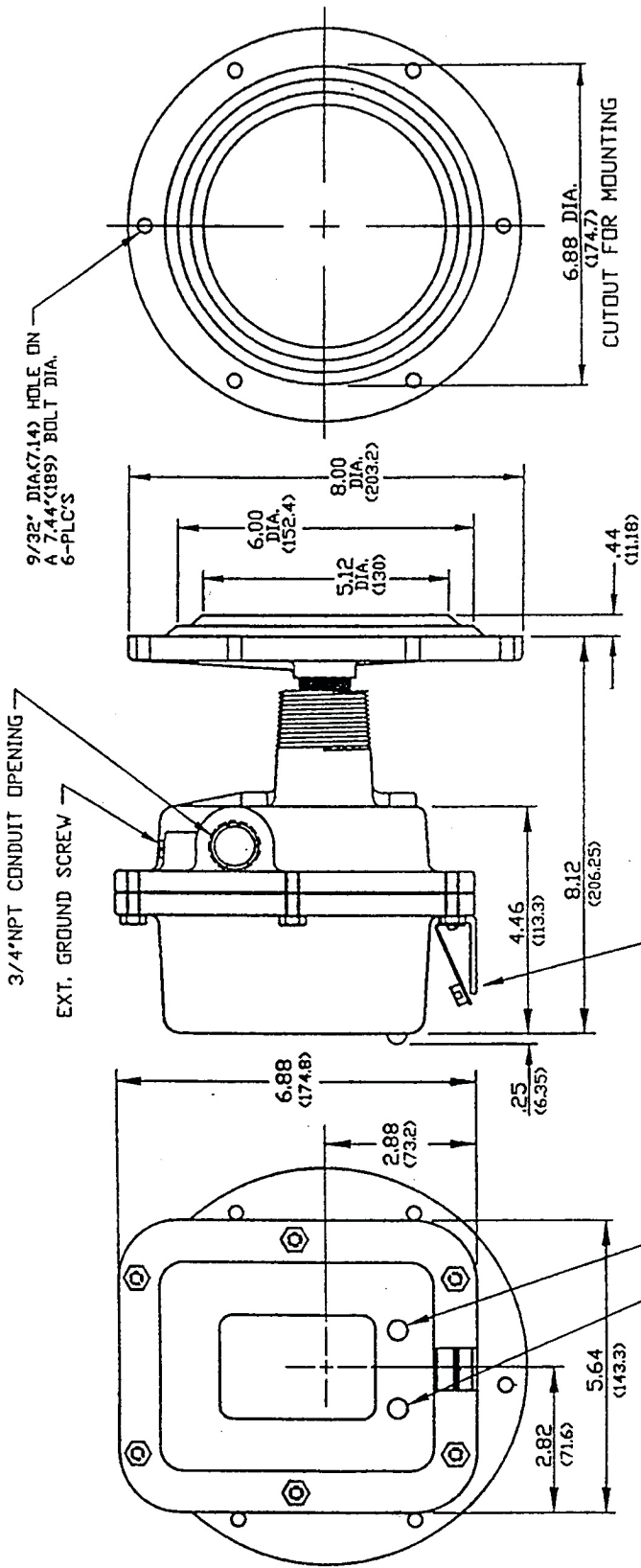

**'CAUTION'**  
 SPRING & MAGNET ASSY FOR RF-9100 ONLY  
 DO NOT SCALE DIMS. ARE IN INCHES  
 BRACKETED DIMS ARE IN MM.

**'CAUTION'**  
 WHEN MOUNTING EXPLOSION PROOF UNITS, NEVER ADJUST THE ORIENTATION OF THE PROBE OR PROBE HOUSING BY TURNING THE HOUSING SECTION. THIS WILL BREAK INTERNAL WIRES AND PERMANENTLY DAMAGE THE PROBE.  
 THE POSITION MUST BE ADJUSTED BY REMOVING THE MOUNTING BOLTS AND MOVING THE ENTIRE PROBE AND HOUSING.

**MOUNTING SURFACE PREPARATIONS**  
 1. LAY OUT TWO CONCENTRIC CIRCLES ON BIN WALL AT POINT WHERE THE RF LEVEL CONTROL IS TO BE MOUNTED. ONE CIRCLE TO BE 6-7/8" DIAMETER, THE OTHER 7-7/16" DIAMETER.  
 2. CUT OUT 6-7/8" DIAMETER CIRCLE.  
 3. LAY OUT SIX EQUALLY SPACED HOLES ON 7-7/16" DIAMETER CIRCLE. DRILL OR TAP FOR 1/4" BOLTS OR CAP SCREWS.

DET. REQD/SHI	DESCRIPTION	MAT. OR PART
UNDESIGNED TIL REWORKED BY MOLDER & L/P CHECKED BY	DRAWN NEAL	PROJ. RB
DATE 9/17/93	RR DATE 9/21/93	DATE 9/21/93
SCALE NONE	SIZE B	PART OR DRAWING LRF180123

FINISH	TITLE	MANUAL DRAWING	GP/XP
	RF9100/9200/8200 FLUSH PROBE		

**BINDICATOR®**  
 PORT HURON, MICHIGAN 48060

REVISIONS		DATE	APP'D

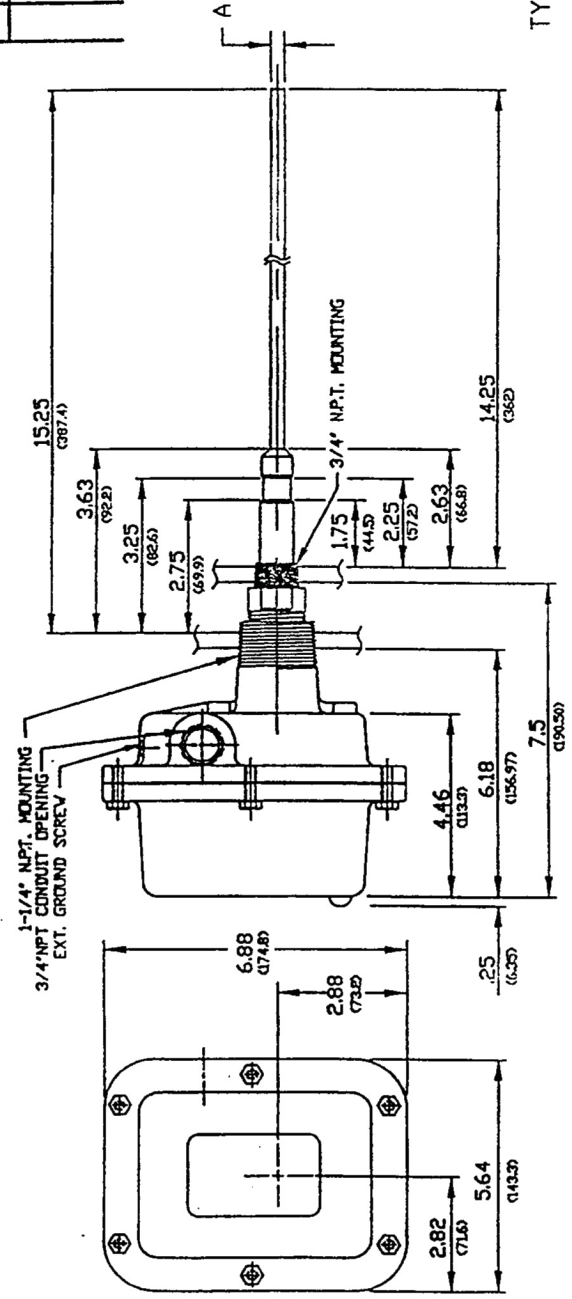

TYPE 'A' MOUNTING

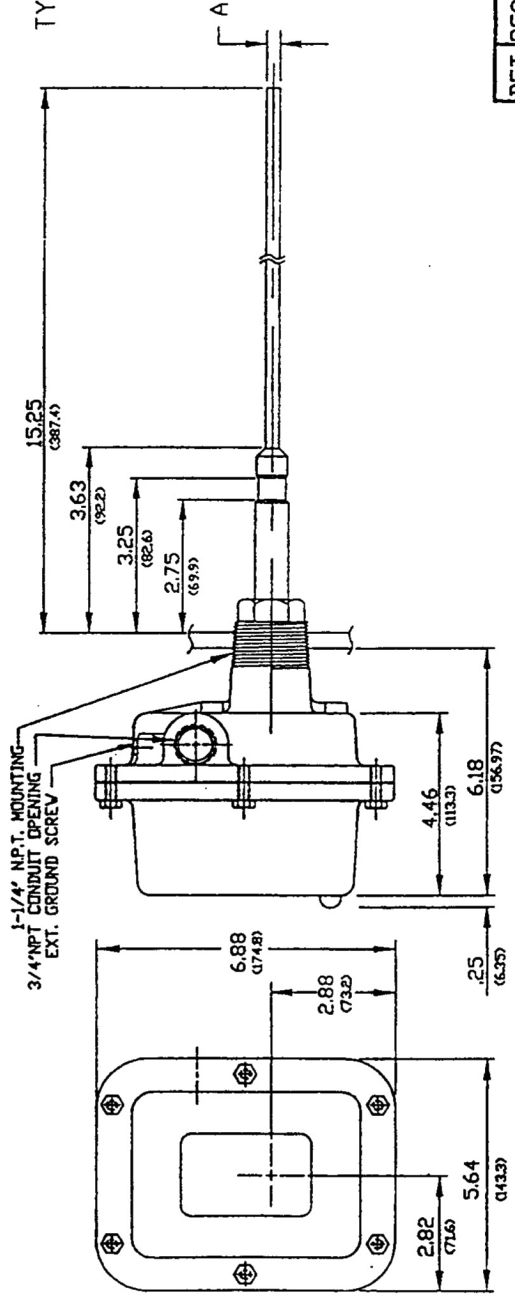

TYPE 'N' MOUNTING

DO NOT SCALE DIMS. ARE IN INCHES  
BRACKETED DIMS ARE IN MM.

MATERIAL FINISH

**BINDICATOR**  
PORT HURON, MICHIGAN 48060

TITLE MANUAL DRAWING RF8200 G/P  
STUB PROBE TYPE 'A' & 'N' MOUNTING

DET.	REQD.	SHT	DESCRIPTION	MAT.	DR PART
DESIGNED BY	DRIVEN	CHECKED	APPROVED	PROD	
REVISIONS #	ARIC C.	DATE	DATE	DATE	
ANGLS & TYPE	10/23/95	11/11/95	11/7/95	11-9-96	
EDGES	SCALE	SIZE	PART OR DRAWING		
	SCALE	SIZE	PART OR DRAWING		
	SCALE	SIZE	PART OR DRAWING		
	SCALE	SIZE	PART OR DRAWING		
	SCALE	SIZE	PART OR DRAWING		

## GENERAL TERMS AND CONDITIONS OF SALE

**1. PAYMENT** Terms of payment are Net 30 days and are effective from the actual date of invoice. If, in the Seller's opinion, the financial condition of the Buyer at any time-or any other circumstances do not justify the incurrence of production costs or shipment on the terms of payment specified, the Seller may require partial or full payment in advance.

**2. F.O.B.** All shipments are F.O.B. Seller's factory in Port Huron, Michigan, unless otherwise stated in the quotation.

**3. QUOTATION AND PRICES** Quoted prices are firm for thirty days and are subject to change without notice after expiration of this period. Orders calling for future deliveries will be invoiced according to prices in effect at the time of shipment.

**4. TAXES** Any applicable sales, use, revenue, excise or other taxes not specifically stated in the quotation are to be remitted by the Buyer directly to the appropriate regulatory agency.

**5. EQUIPMENT WARRANTY/LIMITATION** The following BINDICATOR products are warranted for a period of two years from date of shipment against defective materials and workmanship: RF Series, Mark III Yo-Yo, General Purpose Yo-Yo, Micro-Sonic Series, Eagle, Mach One, Leveldata, Tracker, and Levelite Series. All CELTEK and other Bindicator products are warranted for a period of one year from date of shipment against defective materials and workmanship. WE MAKE NO OTHER WARRANTY, EXPRESS OR IMPLIED, AND ANY WARRANTY OF MERCHANTABILITY OR FITNESS FOR A PARTICULAR PURPOSE WHICH EXCEEDS THE FOREGOING IS HEREBY DISCLAIMED AND EXCLUDED FROM THIS CONTRACT. If the products are being acquired for resale, Buyer will make, in connection with any such resale, only those warranties contained herein and will indemnify us against any claims, causes of actions and judgements which arise from any representations, warranties or agreements made by or entered into by Buyer, other than those contained herein.

**6. BUYER'S EXCLUSIVE REMEDY** In the event of any breach of warranty, the sole and exclusive remedy of Buyer (or any person claiming through Buyer) shall be limited to the repair or replacement of defective products or parts, at our plant or at Seller's option, to the refund of the purchase price, provided that notice of such defects is given within six months after shipment. In no event will our liability include any incidental or consequential damages.

**7. DELIVERY** The Seller shall not be liable for loss or damage of any kind resulting from delay or inability to deliver or account of flood, fire, strike, labor troubles, riot, civil disturbances, accidents, acts or orders or regulations of civil or military authorities, shortages of materials, or any other cause or causes (whether or not similar in nature to any of these enumerated) beyond Seller's control.

**8. PRODUCT CHANGES** In keeping with our continuing policy of product improvement, we reserve the right to make changes in our products at any time, without incurring an obligation to change equipment previously shipped.

**9. RETURN OF GOODS** In no case may products or parts be returned without Seller's prior written permission. Products or parts returned under the aforementioned Equipment Guarantee must be shipped with transportation charges prepaid. All other returns must be shipped with transportation charges prepaid and will be subject to a restocking charge. Only products of standard Bindicator manufacture will be accepted for return. Products which are specially modified or produced to the Buyer's specifications will not be accepted for return.

**10. CONTRACT FORMATION** A binding contract shall not be effective until a written purchase order is received at Seller's office in Port Huron, Michigan and accepted in writing by an authorized employee of the Seller at its Port Huron office. The terms and conditions in our quotation or acknowledgment shall govern the contract and any different or additional terms in Buyer's purchase order, unless approved by Seller in writing, are hereby objected to.

**11. CONSTRUCTION** Any agreement arrived at shall be considered to be a Michigan contract and shall be construed under the laws of the State of Michigan.

**12. CANCELLATION** Request for cancellation must be in writing and referred to Bindicator. No orders will be accepted with the understanding that they may later be cancelled. If and when cancellation is approved by Bindicator, it is with the understanding that Bindicator will be fully reimbursed by payment of cancellation charge; which are to be determined by Bindicator.

**13. CERTIFICATION OF NONSEGREGATED FACILITIES** Our firm does not maintain facilities of a segregated nature contrary to the provision of 41 CFR 60-1.8, and further that if we have 50 or more employees and our contractual arrangements of \$50,000 or more we have complied with 41 CFR 60-1.7 concerning the annual filing of a report on Standard Form 100 (EEO-1) and with 41 CFR 60-1.40 by developing a written Affirmative Action Compliance Program.



150 Venture Boulevard  
Spartanburg, SC 29306  
Phone: (864) 574-8060, Fax: (864) 574-8063  
Customer Service: (800) 778-9242  
Internet: [www.bindicator.com](http://www.bindicator.com)  
Email: [sales@bindicator.com](mailto:sales@bindicator.com)