

RF-9100 & RF-9200 Series
with Design Level 2 Electronics
Installation & Operation Manual

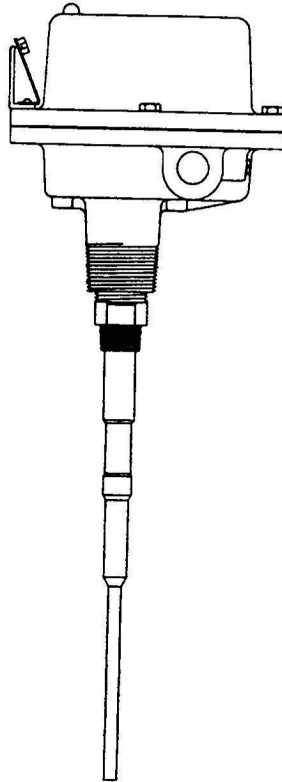

150 Venture Boulevard
Spartanburg, SC 29306
Phone: (864) 574-8060, Fax: (864) 574-8063
Customer Service: (800) 778-9242
Internet: www.bindicator.com
email: sales@bindicator.com

SPECIAL NOTE

The electronics furnished with your RF9100/9200 series level control are a newer design than what you may have purchased in prior years. The ***new "Design Level 2" electronics*** include the following improvements:

- ***DIP switch sensitivity settings...***we now have 8 sensitivity settings versus 3 jumper selections, that were part of the original design. This feature allows you to sense a wider range of materials with one electronics unit.
- ***DIP switch time delay settings...***we now have 4 time delay settings versus 3 jumper selections, that were part of the original design. This feature gives you the flexibility to change time delay from 1 second (minimum) to 7 seconds (maximum) depending on your process.
- ***"Latched" internal calibration push-button...***a momentary push of the calibration button now initiates calibration. You no longer have to hold the button down and wait for the calibration light to illuminate.
- ***"Euro style" terminal block...***which is capable of terminating two - 14 gauge wires. This "safer design" will help protect your personnel or electricians when connecting power to our unit.
- ***Blinking GREEN Calibration Light...***for greater diagnostics and reliable long term calibration.

These features are explained in more detail within this manual.

RF 9100 & RF9200 Series
(with DL2 Electronics)
Installation and Operation Manual

<u>Section</u>	<u>Description</u>	<u>Page Number</u>
1.0	INTRODUCTION	1
2.0	OPERATING THEORY	1
3.0	SPECIAL FEATURES	1
4.0	SPECIFICATIONS	2
4.1	<i>Electronics</i>	2
4.2	<i>Standard Duty Probe</i>	2
4.3	<i>Heavy Duty Probe</i>	3
4.4	<i>Stub Probe</i>	3
4.5	<i>Food Grade Probe with Threaded Connector</i>	3
4.6	<i>Food Grade Probe with Sanitary Connector</i>	3
4.7	<i>Standard Duty Probe -Kynar Coated</i>	3
4.8	<i>Heavy Duty Probe - Kynar Coated</i>	4
4.9	<i>Flush Probe/Dome Flush Probe</i>	4
4.10	<i>Agency Listing</i>	4
5.0	INSTALLATION	5
5.1	<i>Probe Location and Mounting</i>	5
5.2	<i>Installation and Hookup</i>	5
5.3	<i>Fail-Safe Operation</i>	5
5.4	<i>Time Delay</i>	6
5.5	<i>Sensitivity Setting</i>	6
5.6	<i>Calibration</i>	6
5.7	<i>Function Test</i>	8
6.0	TROUBLESHOOTING	8
6.1	<i>Installation Errors</i>	8
6.2	<i>Application Errors</i>	10
7.0	FACTORY ASSISTANCE	10
8.0	WARRANTY & PARTS	10
8.1	<i>Warranty</i>	10
8.2	<i>Electronics Replacement</i>	10
8.3	<i>Parts List</i>	11
9.0	DRAWINGS	11
10.0	MODEL SELECTION	12

Important!
Do not dispose of the carton or packing material until the unit has been inspected for damage.
If the unit is received damaged, notify the carrier or the factory for instructions.
Failure to do so may void your warranty.
Thank you!

1.0 INTRODUCTION

The RF-9100/9200 level control is a point level device used to detect the presence or absence of dry material at a point inside a bin or other vessel. The electronics circuitry can be calibrated either by the internal push-button or with the external spring-loaded magnet or "Fob".

Material coming in contact with the RF probe causes its output relay to change state, thereby indicating to the user material presence to the user.

The RF-9100/9200 utilizes the PRO-GUARD® principle to prevent false indications from material coating or moisture and condensation on the probe.

2.0 OPERATING THEORY

The RF-9100/9200 level control is a relatively low-powered device requiring approximately 4 watts for operation. The power supply accepts 120VAC input power. A varistor is used to filter out power line transients. A 153.6 KHZ RF oscillator provides the signal which is directed to both the PRO-GUARD® and active sensing area of the probe. See Figure 1.

Figure 1

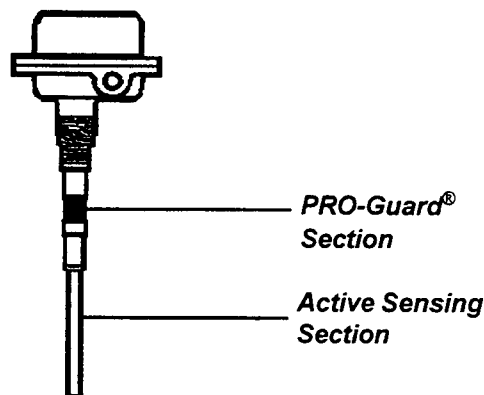

Detection circuitry compares the signal from the active sensing area to a reference RF signal. Since all materials have dielectric constants (relative permittivity) and conductance values different from air, the impedance of the signal changes when material touches the probe. This change causes a shift in phase of the RF signal. A phase difference between the active signal and reference signal causes the output circuit to operate. An RC-time constant delays the actuation or deactuation of the relay for approximately one second.

3.0 SPECIAL FEATURES

The RF-9100 level control has solid-state electronics with an external spring-loaded magnet for calibration. The RF-9200 level sensor uses a "Fob" placed over the cover to initiate calibration. Both sensors feature fail-safe output indication, polyester coated aluminum housing, and PRO-GUARD®.

A very important feature of the RF level control is the ability to ignore the effects of coatings that can adhere to the sensing probe. In most applications, a certain amount of the material that is being sensed will adhere to the sensing probe after a period of time. This can be due to the nature of the material itself or to condensed moisture that can cause dry material to bond to the probe's surface.

PRO-GUARD® disregards the effects of the probe coating and only indicates that material is present when the actual bulk of material in the bin comes in contact with the probe.

Figure 2 shows the PRO-GUARD® probe. The drive current to the PRO-GUARD® electrode is at the same frequency and polarity as the probe. When a coating forms on the probe, the RF current from the PRO-GUARD® tends to saturate that portion of the built up material near the wall so that little or no RF current can flow from the probe to the wall. When the actual bulk material in the bin fills to the point where the material is touching the probe, current from the probe will flow around the saturated region and indicate material presence.

Figure 2

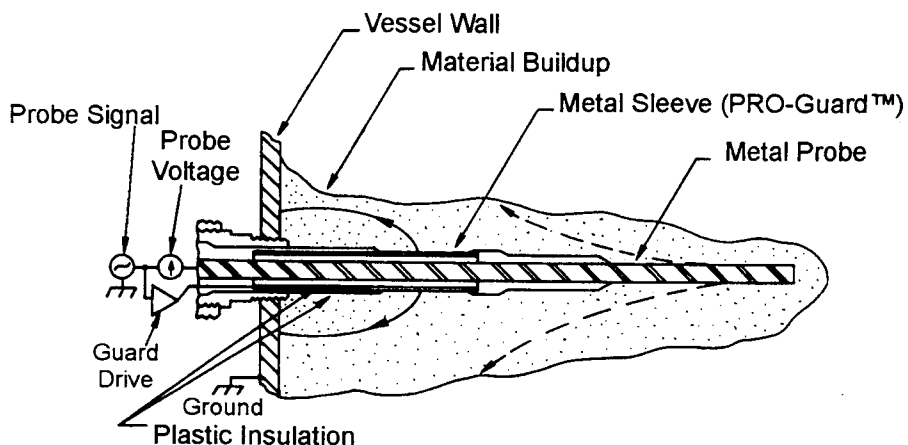

4.0 SPECIFICATIONS

4.1 Electronics

Line Voltage: 120VAC +15%, 240VAC + 15%, 50/60 Hz, 24VDC (factory options)
 Power: 4 W @ 120VAC, 4 W @ 24VDC, 5 W @ 28VDC
 Output Relay: DP/DT, 5 amps at 115VAC
 Temperature Range: -40° F. to +160° F. (-40° C. to +71 ° C.)
 Sensitivity: See Section 5.5
 Time Delay: See Section 5.4
 Calibration: Internal Pushbutton or External Magnet

4.2 Standard Duty Probe

Dimensions: See Installation Drawing
 Mounting: 3/4" NPT 316 S.S. or 1 1/4" NPT Aluminum
 Probe Materials: 316 S. S. and Ryton®
 Pressure: 150 PSI (10.5 Kgs/cm²)** (3/4" NPT fitting only)
 Probe Temperature: The 316 S. S. and Ryton probe is rated from -100° F. to +450° F. (-73° C. to +232° C.).

However, it is recommended that application temperatures be limited to +160° F. maximum as dictated by the temperature rating of the electronics. If a higher temperature rating is required at the application, please consult the factory.

4.3 Heavy Duty Probe

Dimensions: See Installation Drawing

Mounting: 3/4" NPT 316 S.S. or 1 1/4" NPT Aluminum

Probe Materials: 316 S. S. and Ryton®

Pressure: 150 PSI (10.5 Kgs/cm²)** (3/4" NPT fitting only)

Probe Temperature: The 316 S. S. and Ryton probe is rated from -100° F. to +450° F. (-73° C. to +232° C.). However, it is recommended that application temperatures be limited to +160° F. maximum as dictated by the temperature rating of the electronics. If a higher temperature rating is required at the application, please consult the factory.

*Registered trademark of Phillips Chemical Co., Subsidiary of Phillips Petroleum

*For liquid service, use the 3/4" NPT 316 S.S. thread for proper seal. 1 1/4" NPT aluminum may be used for dry materials only.

4.4 Stub Probe

Dimensions: See Installation Drawing

Mounting: 3/4" NPT 316 S. S. or 1 1/4" NPT aluminum

Probe Materials: 316 S.S. and Polysulfone

Pressure: 150 PSI (10 Kgs/cm²)*

Probe Temperature: -30° F. to +300° F. Continuous (-34° C. to +149° C.)

Consult the factory when using in solid, dry materials where active probe length must be reduced or special configurations are required.

4.5 Food Grade with Threaded Connector

Dimensions: See Installation Drawing

Mounting: 3/4" NPT 316 S.S. or 1 1/4" NPT Aluminum

Probe Materials: 316 S.S. and Polysulfone

Pressure: 150 PSI*

Probe Temperature: -30° F. to +300° F. (-34° C. to + 149° C.) Continuous

*For liquid service use the 3/4" NPT 316 S. S. thread for proper seal. 1 1/4" NPT aluminum may be used for dry materials.

4.6 Food Grade with Sanitary Connector

Dimensions: See Installation Drawing

Mounting: Mates with Size 1 Cherry Burrell S® line or Ladish Tri-Clamp®

Probe Materials: 316 S.S. and Polysulfone

Probe Temperature: -30° F. to +300° F. (-34° C. to 149 ° C.) Continuous

4.7 Standard Duty - Kynar® Coated

Dimensions: See Installation Drawing

Mounting: 3/4" NPT - Teflon® Coated

Probe Materials: 316 S.S. and Ryton Coated with Kynar

Pressure: 50 PSI (3 Kgs/cm²)

Probe Temperature: The 316 S.S. and Kynar Coated Ryton probe is rated from -100° F. to +250° F. (-73° C. to +121° C.). However, it is recommended that application temperatures be limited to

+160° F. maximum as dictated by the temperature rating of the electronics. If a higher temperature rating is required at the application, please consult the factory.

4.8 Heavy Duty - Kynar Coated

Dimensions: See Installation Drawing

Mounting: 3/4" NPT - Teflon[®] Coated

Probe Materials: 316 S.S. and Ryton Coated with Kynar

Pressure: 50 PSI (3 Kgs/cm²)

Probe Temperature: The 316 S.S. and Kynar Coated Ryton probe is rated from -100° F to 250° F (-73° C to +121° C). However, it is recommended that application temperatures be limited to +160° F. maximum as dictated by the temperature rating of the electronics. If a higher temperature rating is required at the application, please consult the factory.

*For liquid service, use the 3/4" NPT 316 S.S. thread for proper seal. 1 1/4" NPT aluminum may be used for dry materials only.

**Registered trademark of Pennwalt.

***Registered trademark of DuPont.

4.9 Flush Probe/Dome Flush Probe

Dimensions: See Installation Drawing

Probe Material: 316 S.S. & Epoxy

Pressure: 50 PSI (3 Kgs/cm²)

Probe Temperature: -30° F to +200° F (-34° C to +93° C) Continuous

-30° F to +250° F (-34° C to +121° C) Intermittent

Note: Not For Use In Liquid Service

4.10 Agency Listing

UL Listed Explosionproof, FM & CSA Approved Explosionproof

Dimensions: See Installation Drawing

Various RF Models are available which have been "Listed as complete assemblies by Underwriters Laboratories or FM & CSA approved for use in Class I, Div. I, Groups C & D and Class II, Div. I, Groups E, F & G atmospheres.

To be listed by UL and approved by FM & CSA, these units must contain special intrinsic safety barriers to limit the amount of energy on the probe itself in the event of a failure in the electronics. UL, FM, and CSA also requires a special assembly of the probe to the electronics housing. Because of this special probe seal, the Explosionproof Models are dimensionally different from the General Purpose Units.

The same dimensional difference exists for Coated Standard, Food, Stub and Coated Heavy Duty. No dimensional difference exists in the Flush Probe Units.

On explosionproof units, an approved conduit seal fitting must be installed within 18 inches of conduit opening.

5.0 INSTALLATION

5.1 Probe Location and Mounting

The probe should be located out of the direct flow of the material into the vessel. Protective shields or an offset mounting procedure may be required. Please consult the factory for special mounting problems.

Type "A" Assembly Configuration has been designed to mount on either a 1 1/4" or 3/4" NPT coupling. The 1 1/4" mounting is rated for 50 PSI. The 3/4" mounting has been designed to withstand pressures to 150 PSI. Type "N" Assembly Configuration has been designed for 1 1/4" NPT mounting in dry materials only and has a pressure rating of 50 PSI.

CAUTION:

When mounting explosionproof units, never adjust the orientation of the probe or probe housing by turning the housing section. This will break internal wires and permanently damage the probe.

For tightening units with threaded bin connections, the unit must be positioned by using a wrench on the bin connector. Wrench size required is 1 1/16" with open end.

For "Flush Mount" probe units, the position must be adjusted by removing the mounting bolts and rotating the entire probe and housing.

5.2 Installation and Hookup

Field wiring should conform to the requirements of the National Electrical Code and any other agency or authority having jurisdiction over the installation. Refer to Installation Drawings for proper installation and hookup and wiring instructions.

CAUTION:

Use caution when preparing all wires for connection to the terminal block. Strip insulation a maximum of 1/4" or use insulated wire ferrules such as Altech 8969.0 or Altech 2206.0 to prevent shorting of conductors. Tighten screws in terminal block to 4 in/lbs.

5.3 Fail-Safe Operation

The RF level control is in the high level fail-safe condition. Please contact Bindicator if low level fail-safe is required.

High Level Operation - If the electrical power fails, the relay turns off. This indicates material as if the tank were full. (Refer to illustration below.)

Material Present - Red Alarm LED Light ON - Relay Off
 No Material Present - Red Alarm LED Light OFF - Relay On

High Level Operation

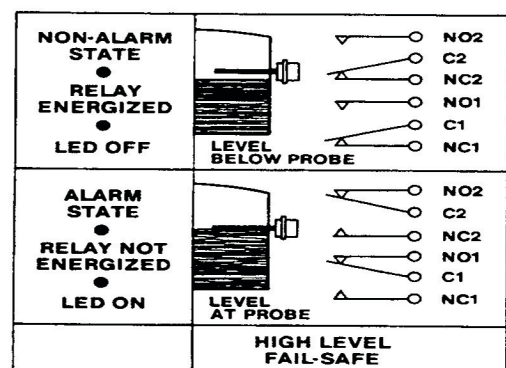

The relay contact terminals on TB 2 are labeled in the powered, unalarmed state. This status may be opposite that of other brands of level controls. Contacts as marked on TB2 are not the relays nomenclature, but are marked so contacts are in "normal" positions when unit is powered and unalarmed.

5.4 Time Delay

When the RF9100/9200 unit is used in liquid or agitated material where material movement could cause false or premature level indication, an increased time delay selection may be desirable.

Note:

The RF9100/9200 is shipped from the factory in the minimum time delay condition. Increased time delay selection is made by changing the Dip Switch Settings. (See Figure 3, page 9)

Available Time Delay Settings are:

- switch 1 off and switch 2 off = 1 second minimum
- switch 1 on and switch 2 off = 2 seconds
- switch 1 off and switch 2 on = 4 seconds
- switch 1 on and switch 2 on = 7 seconds maximum

5.5 Sensitivity Setting

Due to variation in material characteristics, correct sensitivity selection is critical to assure proper unit operation. This can be field programmable to one of the eight predetermined settings. (see Figure 3 or 4).

High Sensitivity Hard to detect materials such as plastic pellets, light powders, and dry grain.

Medium Sensitivity Most dry or liquid materials such as cement, petroleum products or flour.

Low Sensitivity Most liquid solutions such as aqueous solutions, acids.

Note:

The RF-9100/9200 sensors are shipped from the factory in the high sensitivity condition. Selection is made by changing the Dip Switch Settings.

Sensitivity Setting

- switch 1 off and switch 2 off and switch 3 off = 1 pF High
- switch 1 on and switch 2 off and switch 3 off = 1.5 pF
- switch 1 off and switch 2 on and switch 3 off = 2.0 pF
- switch 1 on and switch 2 on and switch 3 off = 3.0 pF Medium
- switch 1 off and switch 2 off and switch 3 on = 10.0 pF Low
- switch 1 on and switch 2 off and switch 3 on = 12.0 pF
- switch 1 off and switch 2 on and switch 3 on = 14.0 pF
- switch 1 on and switch 2 on and switch 3 on = 15.0 pF Low/Low

5.6 Calibration

CAUTION: MATERIAL MUST BE WELL BELOW PROBE BEFORE CALIBRATION PROCEDURE BEGINS. IF EXTERNAL CALIBRATION IS ATTEMPTED WHEN MATERIAL IS IN CONTACT WITH THE PROBE, THE UNIT WILL NOT CALIBRATE.

IF THE UNIT IS CALIBRATED WITH THE INTERNAL CALIBRATION BUTTON WHEN MATERIAL LEVEL IS AT THE PROBE, THE UNIT WILL NOT BE ABLE TO SENSE THE PRESENCE OF MATERIAL.

Prior to operation, the RF level control must be calibrated in order to match the operating characteristics of the vessel. The unit may be calibrated locally at the electronics either by internal or external means.

External Calibration

The cover should be securely in place and the red alarm LED must be off. If unit is other than HLFS then See Section 5.3 and consult factory. (The external calibration feature is disabled if the unit is in the alarm state.) Momentarily depress the external spring-loaded calibration switch so that the magnet makes contact with the side of the cover for about one second, then release the switch.

Note:

For models with "Fob" calibration, simply locate the "Fob" over the RED and GREEN LEDs momentarily and then remove, or position Fob over the decal labeled "CAL" on the side of the unit. (See Figure below)

When calibration is initiated, the green LED will go out - if not already out. When calibration is complete, the green calibration LED will come on and stay on. If the red alarm LED is on, verify that material is not at the probe and calibrate internally.

Calibration:

- Hold Fob as shown for 2 seconds - then remove.
- Green lamp will go out and relight when calibration is complete (in 2 -25 seconds).

Test:

- Hold Fob as shown.
- Red lamp will come on indicating "High Level" Alarm.

("Fob" locations for units with "Function Test" Option only)

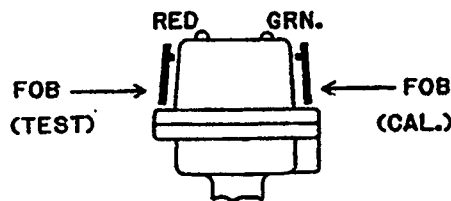

Internal Calibration:

The magnetic calibration feature will not allow the sensor to be calibrated when the sensor is in the alarm condition. However, if the sensor is in the alarm condition because of excessive material buildup on the sensing probe, the sensor can be calibrated. To calibrate the sensor in this condition, simply remove the cover and momentarily press the internal calibration button. The green LED comes is complete. Immediately upon pushing the button, the green calibration LED will go out - if not already out. When calibration is complete, the green calibration LED will come on. The green LED will stay illuminated. Recalibrate any unit whose green calibration light is off.

NOTE: Calibration for both of the above methods should be completed within 2 to 25 seconds. Consult the factory if calibration is not within this time. Red alarm LED should be off when calibration is completed. If unit is in "Low Level Fail-safe" (See Section 5.3) LED will be on when calibration is completed.

5.7 Blinking Green Calibration LED

A new feature of the Design Level 2 Electronics is the ability to differentiate between a failure in the calibration setting, and a slight change in the sensitivity/calibration that may be caused by changes over time in temperature, material coating, and normal electronics drift.

- If the green calibration LED is continuously illuminated, then the unit is at perfect or near perfect calibration. NOTE: the green calibration LED will also remain on if unit has failed in "Fail-Safe High" mode or whenever unit is in alarm.

- When the green calibration LED is blinking on and off at approximately 2 times per second, it indicates the unit is no longer at "Perfect Calibration", but has changed slightly. In most cases this small change will not effect the ability of the unit to sense the material when it comes in contact with the probe. Recalibrate the unit at your convenience.

- When the green calibration LED is off (not illuminated), it either indicates a failure in the calibration, or change in material coating the probe. This unit will need to be recalibrated as soon as possible. Contact Bindicator if this condition happens frequently.

5.8 Function Test

The "Function Test" feature is now standard on all Design Level 2 units.

Set the function test selection jumper to the same setting as the sensitivity selector. (Example: If sensitivity is "High" then position the function test jumper in the middle position. If sensitivity selection was a setting between High and Medium, then set the test in the Medium position. If sensitivity selection was a setting between Medium and Low, set the test in Low position. (See Section 5.5 and Figure 3).

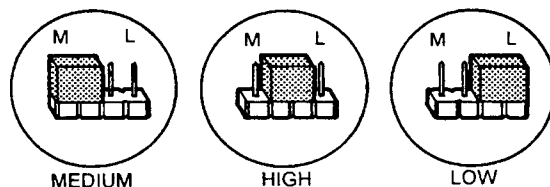

Placing the Fob in the test position (refer to figure in Section 5.6) will initiate a test of the unit. This test is only practical when material level is below the probe.

If the unit is in calibration and capable of sensing material at the probe, the output relay will go into the alarm state and the red LED will illuminate when the Fob is placed in test position. The test can also be initiated internally by pushing the "Function Test Push-button", See Figure 3.

6.0 TROUBLE SHOOTING

6.1 Installation Errors

Probe should be located out of the direct flow of material while the vessel is being filled. Unit should be mounted with the conduit opening down and located, if possible, higher than the conduit raceway. This will eliminate the possibility of moisture settling in the conduit outlet box. If the conduit is higher than the unit, provide a conduit loop under the conduit outlet box with a conduit drain fitting.

Mounting the probe in a nozzle or location where material bridges excessively may cause false indication. The probe should be mounted so material does not build up excessively over the PRO-GUARD® area of the probe. (See Figure 1.) If the probe is mounted in a nozzle or nipple, the PRO-GUARD® area must be inside the vessel.

Maintenance Note

A replaceable coin-type lithium battery is used to help maintain calibration data in the RF electronic unit. Recommended maintenance is replacement after every 3 years of operation. The battery is located on the Power Printed Circuit Board Assembly, just under the corner of the Light Printed Circuit Board Assembly. (See Figure #3) To remove, simply lift the edge of the battery and slide it from the holder. To replace, slip the new battery in under the contact arm until the new battery is firmly seated into the holder. As replacement, use ONLY lithium coin-type battery #CR1620 (Bindicator part # LUC036952).

Figure 3
(Electronic Unit with Function Test)

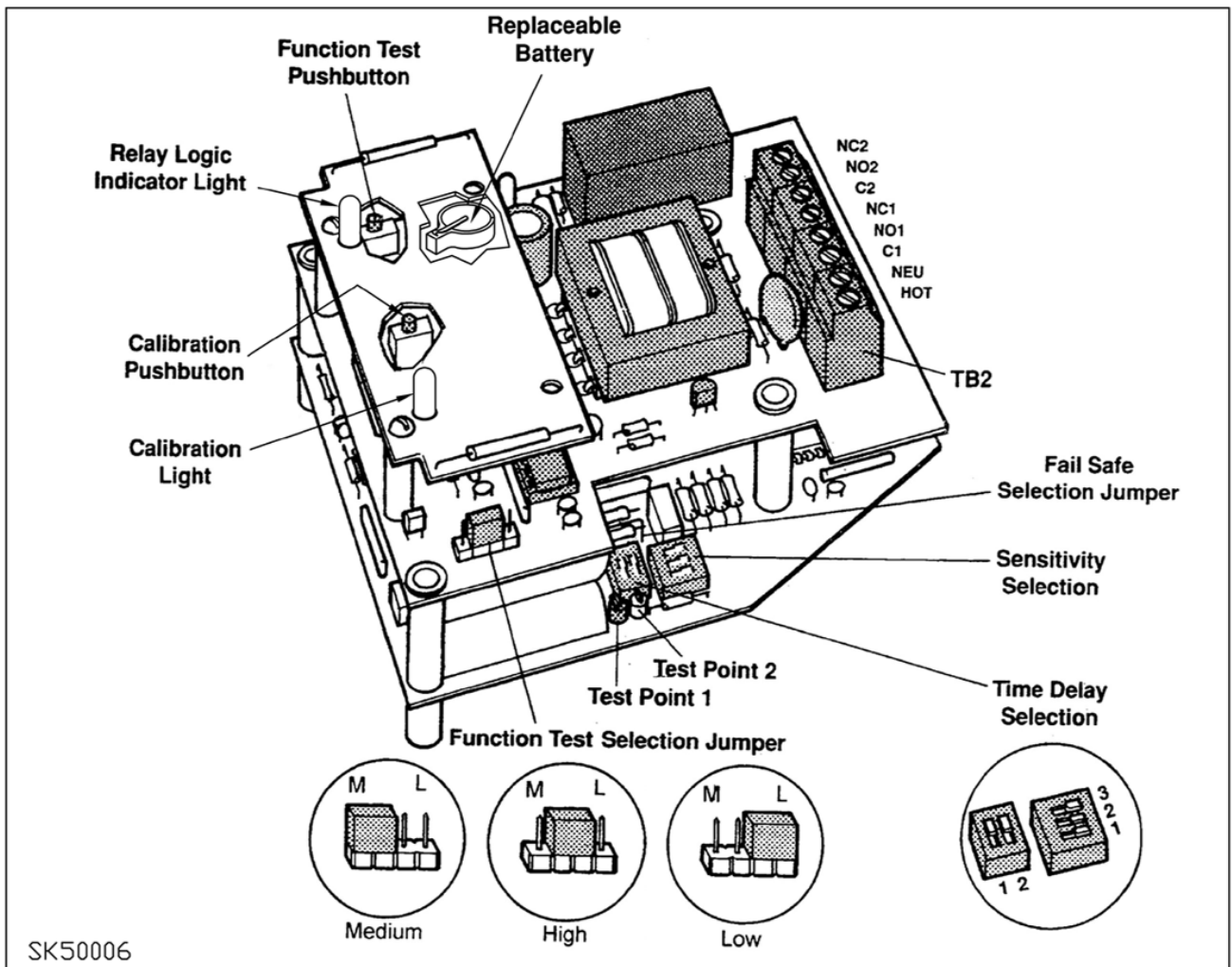

Vertical mounting reduces bridging problems. If material to be sensed is of a nature where buildup will continue to grow on the probe, vertical mounting is necessary.

6.2 Application Errors

A. *Extreme Material Buildup* - Use in materials where a continually, growing buildup of a conductive material will occur should be avoided. The PRO-GUARD® will prevent false indication from material coating and condensation, but a continually, increasing buildup will eventually exceed even the PRO-GUARD® capability. Recalibration of the electronics may cancel the effects of material buildup. Refer to the "Internal Calibration" procedure.

B. *Highly Corrosive Material* - Wetted probe parts consist of 316 S.S., epoxy, polysulfone, Kynar® and Ryton® depending upon the probe selected. The enclosure is constructed in aluminum with a polyester coating. If you believe the materials in contact with the probe or mounting may cause corrosion with aluminum, insulation materials, or 316 S.S., consult the factory.

C. *Extremely Light and Dry Materials* - Use in very light materials (less than 30 lbs./cu. ft.) and very dry, non-conductive materials (less than 3% moisture) may require high sensitivity electronics or sensitivity attachments to the probe.

D. *High Vibration* - Use in vessels and bins with vibrators and other considerable vibration should be avoided. If the application does involve vibration, consider the RF-10000, RF-11000 or RF-12000 with remote electronics. (Consult Factory)

7.0 FACTORY ASSISTANCE

If attempts to locate any difficulties with the unit fail, notify your local representative. To help solve your problem quickly, please have as much of the following information as possible:

- Model number
- Date purchased
- Brief application information such as: material to be detected, approximate vessel size and location of unit (s) in the vessel.
- Brief description of the problem such as: fails to detect material, or intermittent false alarms
- What investigation has been performed by the user and what was discovered

If your local representative is unable to determine the cause of your difficulty, they will refer you to a factory engineer. Equipment shipped back to the factory without proper authorization, will be refused and returned at the shipper's expense.

8.0 WARRANTY & PARTS

8.1 Warranty

Refer to Manufacturer's General Terms and Conditions of Sale for warranty information.

8.2 Electronics Replacement

Replacement Electronics are readily available for your RF Model. There are two methods to determine the correct part number for the electronic unit.

1. Call Bindicator Customer Service Department with the Model number of your unit. They will search a computer database and advise you of the part number.

2. Find the Serial number located on the bottom side (where the probe wires connect) at the electronic unit. The serial number is written with black permanent marker. The first three digits of the serial number are the last three digits of the part number. Just add the prefix LRF110 to these three numbers and you have the part number. EXAMPLE: Serial number reads 302 9326-05, part number is LRF110302.

8.3 *Parts List*

The RF level control is designed to give years of unattended service. No scheduled maintenance or parts service is required.

9.0 DRAWINGS

<u>Drawing Number</u>	<u>Description</u>
B-LRF110025	Probe Cable Termination Ext./Lag Ass'y
B-LRF180106	Probe Accessories
B-LRF180118	Pipe Extended Units
B-LRF180119	Type "N" Mounting
B-LRF180120	UL Explosionproof Dimensions
B-LRF180121	Sanitary Mounting - Explosionproof
B-LRF180122	Sanitary Mounting - General Purpose
B-LRF180123	Flush Probe
B-LRF180124	Dome Flush Probe
B-LRF180131	Type "A" Mounting
B-LRF180132	RF-9100/9200 AC/DC Hook-up
B-LRF180162	RF-9100/9200 Lagged GP
B-LRF180132	RF-9100/9200 Teflon jacketed Probe

10.0 MODEL SELECTION for Design Level 2 Units

Model Code

RF9 - - - - - (SEE NOTE 3)

Assembly Configuration

- A = 3/4" S. S. & 1 1/4" Alum. & Flush Mount
- B = Pipe Ext. Probe, SS Coupling
- C = Pipe Ext. Probe, Plated Coupling
- S = Sanitary Connector
- N = 1 1/4" Alum. Only. (NEMA 4 Only) - Consult factory for agency listing) (See Note 2)

Voltage

- 1 = 120VAC
- 2 = 240VAC
- 3 = 24VDC
- 4 = 12VDC
- 5 = 24VAC
- 6 = 48VAC

Enclosure Type

- G = General Purpose NEMA 4/5
- X = Explosionproof NEMA 7,9 UL
- B = Explosionproof NEMA 7,9 (BASEEFA)

Probe Type

- 0 = Standard
- 1 = Standard, Kynar® Coated
- 2 = Food Grade
- 4 = Stub
- 5 = Heavy Duty
- 6 = Heavy Duty, Kynar® Coated
- 7 = Dome Flush Mount (Specify Thickness - Use with Configuration "A" Only)
- 8 = Flush Mount
- A = Armored Food Grade (Use with Configuration "A" Only)

Electronics

- C = Standard Sensitivity With Functional Test
- D = Sensitivity Modification (.5pf) with Function Test

Type Of Calibration

- 1 = With External Spring Calibration
- 2 = With "Fob" Calibration (See Note 1)

RF-9100/9200 Radio Frequency Type Series

Note 1: External calibration "Fob" for "Type 2" calibration - "C" Electronics must be ordered as a separate part (LRF130119).

Note 2: Do Not use for liquid service

Note 3: for 3A certification, add "3A" at end of Model Code. Price adder is \$50.00. Configuration "S" must be used and either "Type 2" Food Grade or "Type 4" Stube Probe.

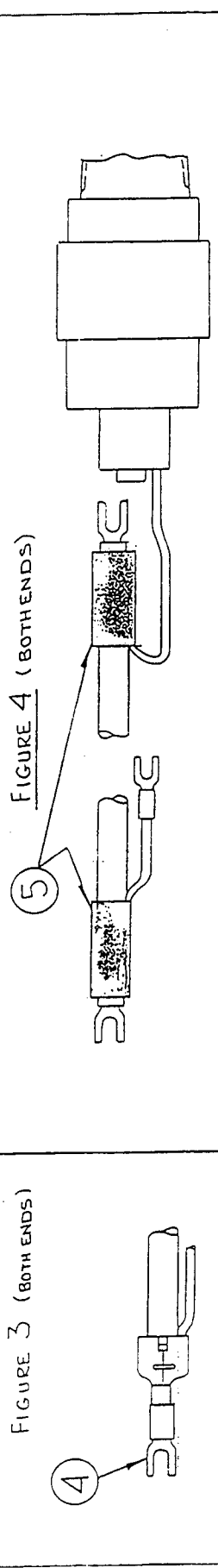
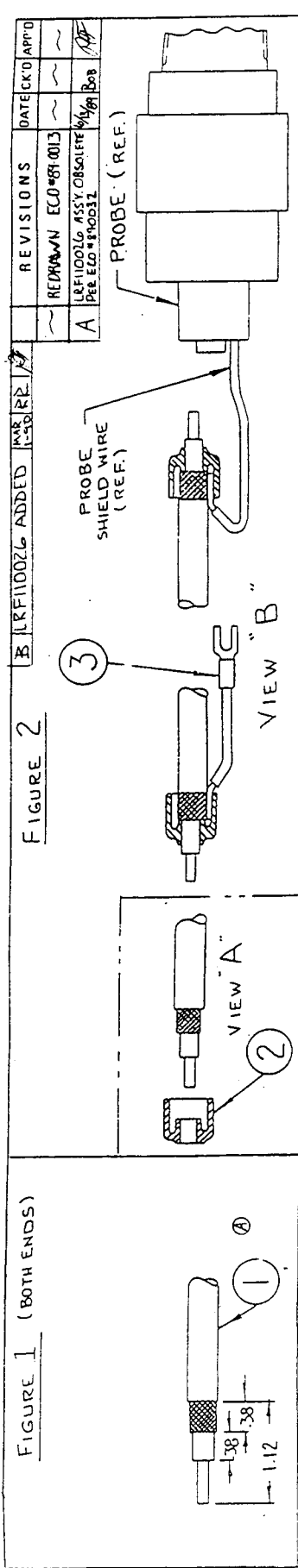

INSTRUCTIONS

- 1) CUT CABLE (ITEM #1 OR #6) TO LENGTH SPEC. ON ORDER.
- 2) STRIP BOTH ENDS OF CABLE AS SHOWN IN FIGURE 1.
- 3) INSERT FERRULE (ITEM #2) ON THE CABLE AS SHOWN IN FIGURE 2, TYP. BOTH ENDS. INSERT SHIELD WIRE ASSY (ITEM #3) ON ONE END OF CABLE. CUT SHIELD WIRE COMING OUT OF PROBE TO $3\frac{1}{2}$ " LONG & STRIP END. INSERT THIS WIRE ON OPPOSITE END OF CABLE. CRIMP BOTH ENDS USING AMP TOOL 59500 WITH INSERT 45066-3.
- 4) INSERT TERMINALS (ITEM #4) ON CENTER CONDUCTOR OF CABLE. (BOTH ENDS). CRIMP USING HAND CRIMP OR RATCHET TOOL. SEE FIG. 3.
- 5) PLACE SHRINK TUBE (ITEM #5) OVER CABLE ENDS AS SHOWN IN FIGURE 4. HEAT SHRINK AT LESS THAN 250°F FOR AT LEAST 30 SECONDS.

ASSY N°	DETAILS	DESCRIPTION
LRF110025	1 THRU 5	CABLE TERMINATION ASSY
LRF110026	2 THRU 6	HIGH TEMP CBL. TERM. ASSY.

6	A.R. CABLE HI STABILITY COAXIAL	UX035209
5	SHRINK TUBING 2.0"	UX035210
4	TERMINAL STA-KON	UX030340
3	ASSY - SHIELD WIRE	LB002140
2	FERRULE	UX032120
1	A.R. CABLE COAXIAL	UX035208

DRY	NEAL	DATE	8-MAR-89
CHECKED	NEAL	DATE	8-MAR-89
APPROVED	NEAL	DATE	8-MAR-89
PROOF	NEAL	DATE	8-MAR-89

UNSPECIFIED OR ORIGINALS: XXX	ANGLES: 1/4"	DO NOT SCALE
FINISH	SCALE	DIMENSIONS ARE IN INCHES
NEXT ASSY.	SCALE	
TITLE	SCALE	
TERMINATION	SCALE	
PROBE CABLE	SCALE	
EXT. MAG. ASSYS	SCALE	

REV	REVISIONS	DATE	CK'D	APP'D
A	REPAIRMAN ECO #810013			
	LRF110026 ASSY OBSOLETE PER ECO #810032			
	PROBE (REF.)			
	PROBE SHIELD WIRE (REF.)			



BINDERATOR
PORT HURON, MICHIGAN 48060

REVISED	EXT. GRD. ADDED	REVISIONS	DATE	CK'D	APP'D
		A	11/17/88	RL	RC
		B	11/17/88	RL	RC
		C	11/17/88	RL	RC
		D	11/17/88	RL	RC

CHANGE	DATE	BY	APP'D
ADDED PROBE SET	11/17/88	RL	RC
WAS 1.375 PERIOD	11/17/88	RL	RC

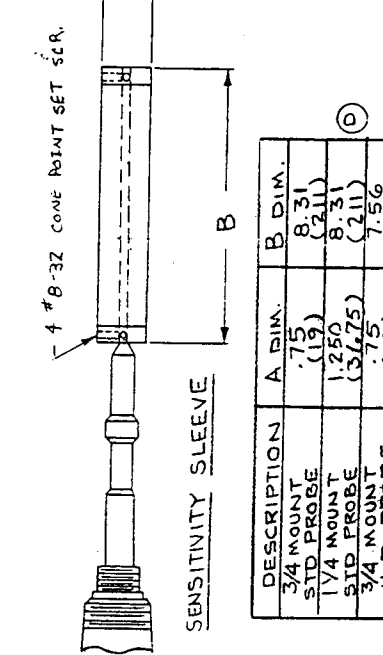

DESCRIPTION	A DIM.	B DIM.
3/4 MOUNT STD PROBE	.75 (19)	8.31 (211)
1/4 MOUNT STD PROBE	1.250 (31.75)	8.31 (211)
3/4 MOUNT H.D. PROBE	.75 (19)	7.56 (192)
1/4 MOUNT H.D. PROBE	1.250 (31.75)	7.56 (192)

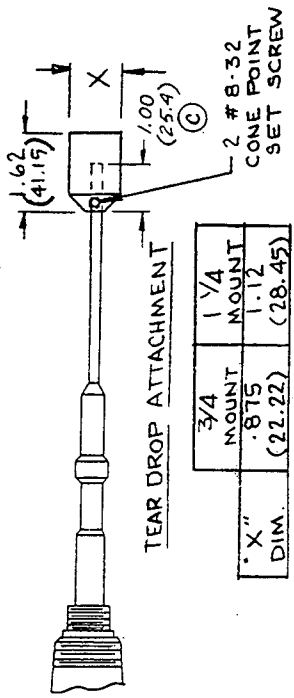

3/4 MOUNT DIM.	1/4 MOUNT DIM.
.875 (22.22)	1.12 (28.45)

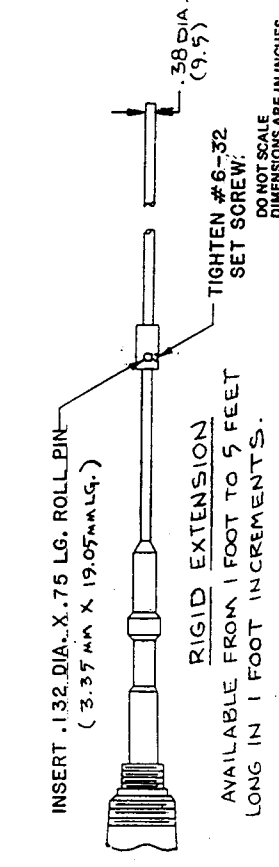
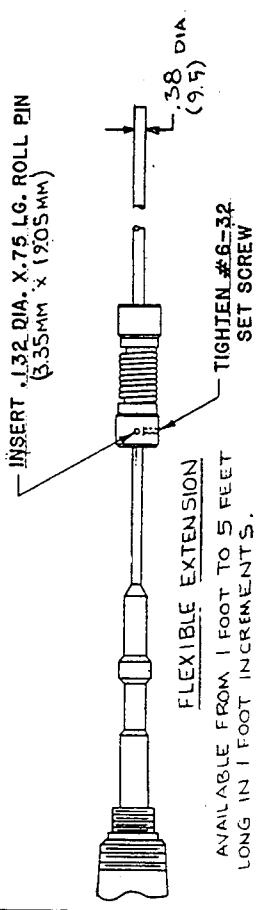
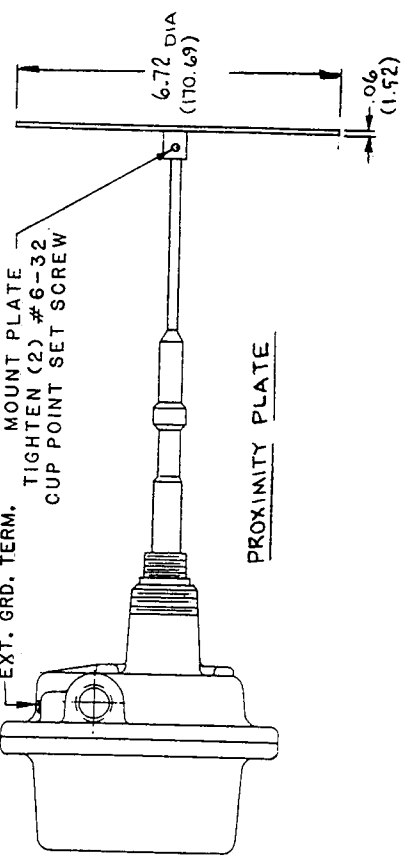

DET.	REQ'D.	SHT.	D-DESCRIPTION	MAT. OR PART
UNSPECIFIED TO	APPROVED	PRO'D		
DIMENSIONAL	DATE	DATE		
ANGLES	DATE	DATE		
DEBURR & BREAK	DATE	DATE		
EDGES DOG	DATE	DATE		
NEXT ASSY.	DATE	DATE		
MATERIAL			SCALE	PART OR DRAWING
FINISH			NONE	B
TITLE			MANUAL DRAWING	PREVIOUS
MATERIAL			PROBE ACCESSORIES	
BINDERATOR®			REF. LRF180106	
PORT HURON, MICHIGAN 48860				

REVISIONS		DATE	BY	APP'D

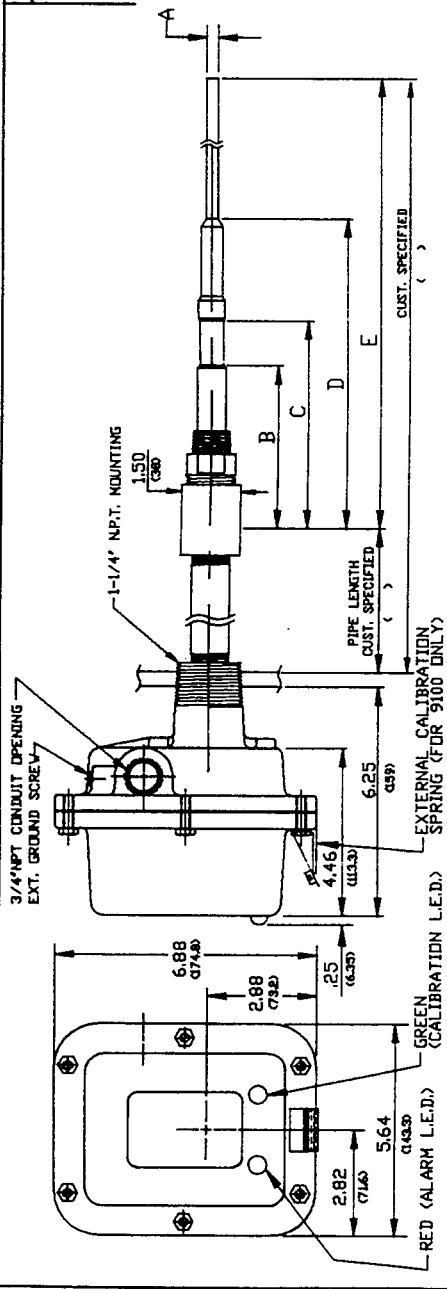

TYPE 'C' MOUNTING

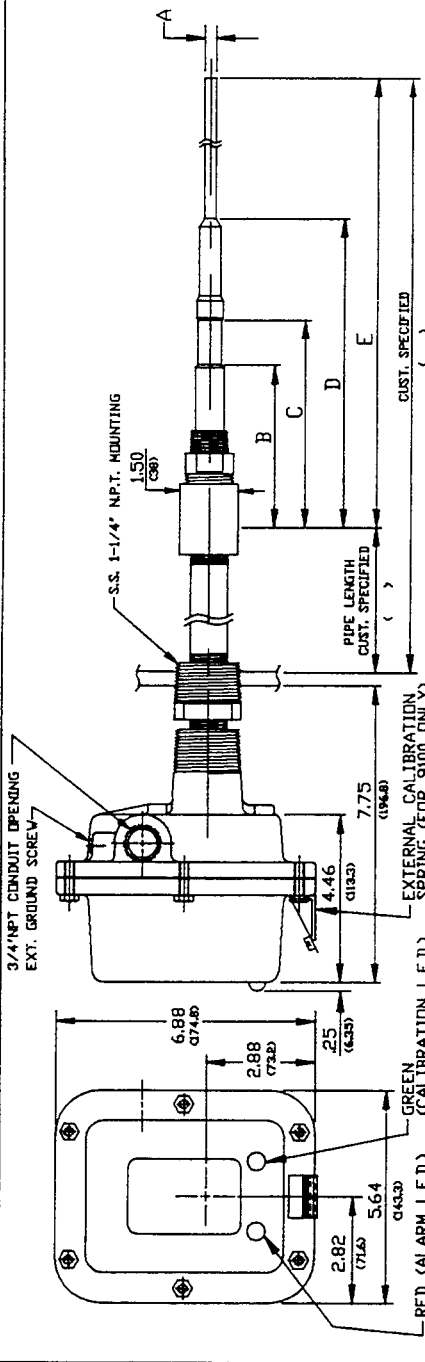

TYPE 'B' MOUNTING

APPROX DIM'S	STD. & FOODGRADE	H.D.	STD. KYNAR H.D. KYNAR COATED	STUB
A	.31 DIA. (.8)	.31 DIA. (.8)	.31 DIA. (.8)	.31 DIA. (.8)
B	.31 DIA. (.8)	.31 DIA. (.8)	.31 DIA. (.8)	.31 DIA. (.8)
C	5.88 (149)	5.88 (149)	5.88 (149)	5.88 (149)
D	8.50 (216)	8.50 (216)	8.50 (216)	8.50 (216)
E	16.50 (419)	16.88 (428.75)	20.88 (530.35)	16.50 (419)

DO NOT SCALE DIM'S. ARE IN INCHES
BRACKETED DIM'S ARE IN MM

DET. REQ'D	REQ'D SHIT	DESCRIPTION	MATOR PART
UNSPECIFIED TEL. DRAWN BY NEAL DATE 1/27/92	APPROVED BY DATE 1/27/92	DESCRIPTION	MATOR PART
ANGLES & V.P. CHECKED BY DATE 1/27/92	DATE 1/27/92	DATE 1/27/92	DATE 1/27/92
SCALE NONE	SCALE NONE	SCALE NONE	SCALE NONE
PART OR DRAWING SIZE B	PART OR DRAWING SIZE B	PART OR DRAWING SIZE B	PART OR DRAWING SIZE B

TITLE MANUAL DRAWING
RF 9100/9200 EXTENDED, G/P



PORT HURON MICHIGAN 48060

LRF180118

REVISIONS		DATE	BY	APP'D
A	NOW OUTLINE FOR RF8200 PER PROJECT #A-9503	AC		RB
B	KYNAR OPTION REMOVED PER ECD 96-020	AC		RB
C	6.25 WAS 8.12 PER ECD 96-049	AC		RB

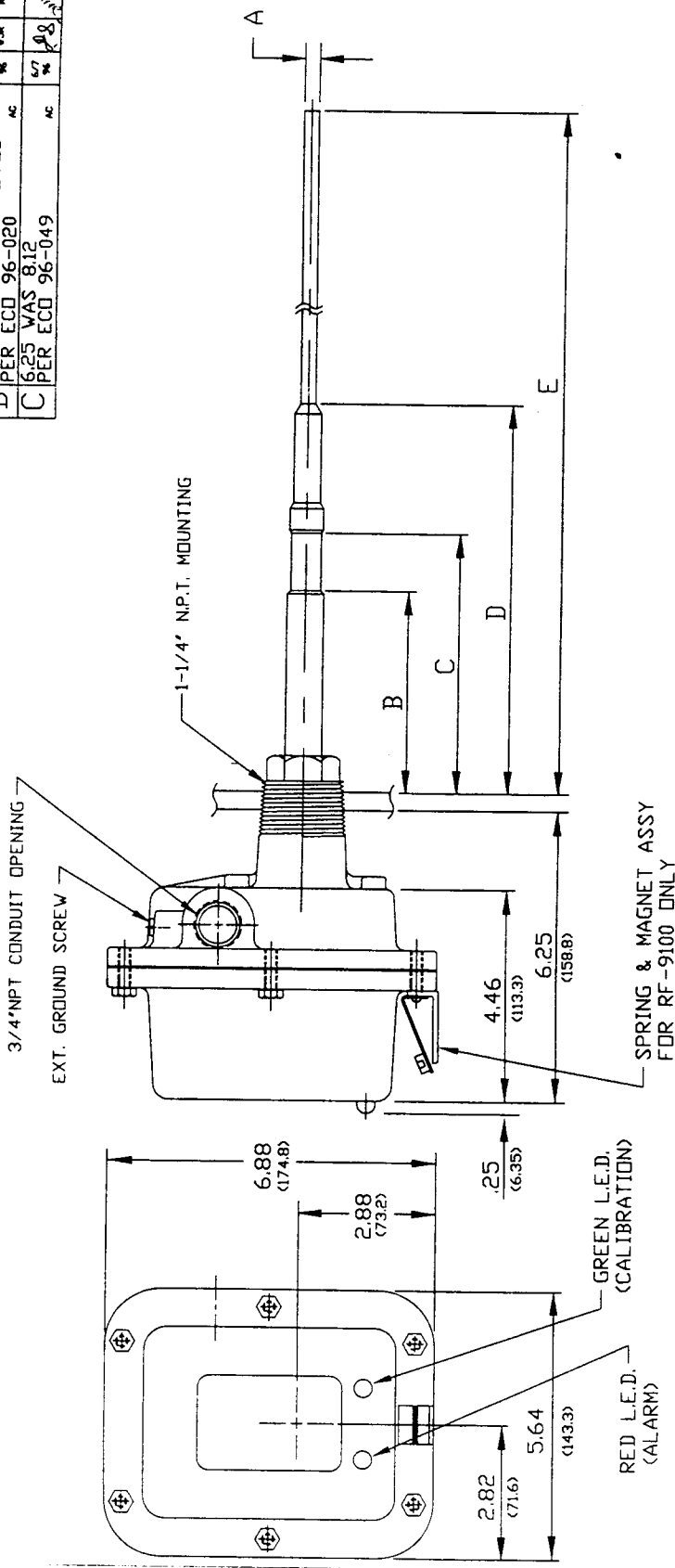

APPROX DIM'S	STD. & FOODGRADE	H.D.	
E	15.25 (387.5)	19.25 (489)	
D	7.00 (178)	11.75 (298.5)	
C	4.50 (114.5)	10.00 (254)	
B	3.38 (86)	8.5 (216)	
A	.31 DIA. (8)	.38 DIA. (9.5)	

DO NOT SCALE DIM'S. ARE IN INCHES
BRACKETED DIM'S ARE IN MM.

DET. REQ'D	DESCRIPTION	MAT. OR PART
UNSPECIFIED TEL. DRAWING	CHECKED	APPROVED
REVISIONS	LANGOLF	RZ
DATE	4/24/92	DATE
4/24/92	4/27/92	4/27/92
SCALE	NONE	PART OR DRAWING
	B	LRF180119

TITLE MANUAL DRAWING
PORT HURON MICHIGAN 48050 RF9100/9200/8200 G/P, TYPE 'N' MOUNTING

REVISIONS		DATE	CHK'D	APP'D
	REDRAWN ON CAD			
A	SPELLING ERROR, TIGHTENING WAS TIGHTENING.	11/12/93	JN	RB
B	NEW OUTLINE FOR RF8200 PER PROJECT#A-9503	10/20/95	VJR	RB
C	6.75 WAS 6.37 PER ECD 96-049	6/7/96		

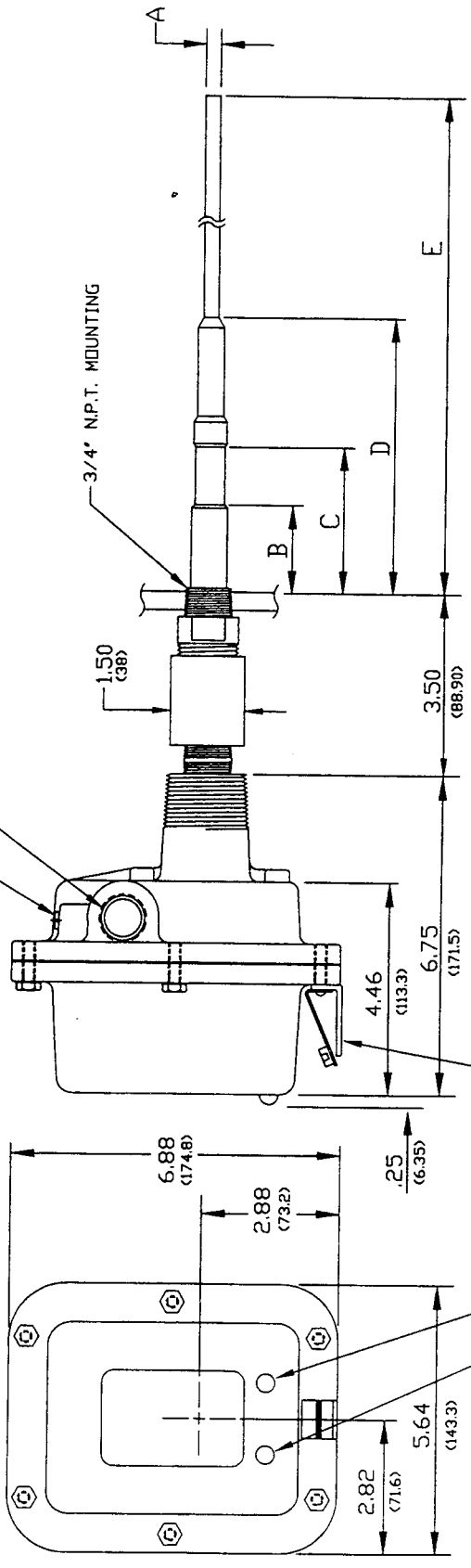

"CAUTION"
 WHEN MOUNTING EXPLOSION PROOF UNITS, NEVER ADJUST THE ORIENTATION OF THE PROBE OR PROBE HOUSING BY TURNING THE HOUSING SECTION. THIS WILL BREAK INTERNAL WIRES AND PERMANENTLY DAMAGE THE PROBE.
 FOR TIGHTENING UNITS WITH THREADED BIN CONNECTIONS, THE UNIT MUST BE POSITIONED BY USING A WRENCH ON THE BIN CONNECTOR. WRENCH SIZE REQUIRED IS 1-1/16 INCH OPEN END.

APPROX DIM'S	STD. & FOODGRADE	H.D.	STD. KYNAR COATED	H.D. KYNAR COATED	STUB
E	14.25 (362)	18.25 (463.5)	14.62 (371.4)	18.62 (472.95)	14.25 (362)
D	6.00 (152.5)	10.75 (273)	6.00 (152.5)	10.75 (273)	2.63 (66.8)
C	3.50 (89)	9.00 (228.5)	3.50 (89)	9.00 (228.5)	2.25 (57.2)
B	2.38 (60.5)	7.50 (190.5)	2.38 (60.5)	7.50 (190.5)	1.75 (44.5)
A	.31 DIA. (8)	.38 DIA. (9.5)	.31 DIA. (8)	.38 DIA. (9.5)	.31 DIA. (8)

DO NOT SCALE DIM'S. ARE IN INCHES
 BRACKETED DIM'S ARE IN MM.

DET.	REQD'SH	DESCRIPTION	MATERIAL PART
UNSPECIFIED TEL. NO.	LANGOLF	CHECKED	PROD.
TECHNICAL MANAGER	RANDY	APPROVED	RB
DATE	DATE	DATE	DATE
4/25/92	4/27/92	4/27/92	4/27/92
ANGLES TO BE SHOWN	SCALE	PART OR DRAWING	
BEHIND & BREAK EDGES OK	NONE	B	LRF180120

BINDIATOR
 PORT HURON, MICHIGAN 48060

TITLE MANUAL DRAWING
 RF 9100/9200/8200 UL X/P

REVISIONS		DATE	BY	APP'D
A	SPELLING ERROR, TIGHTENING WAS TIGHTENING.	07/18/93	JN	RB
B	NEW OUTLINE FOR RF8200 AC PER PROJECT#A-9503	07/20/95	JN	RB

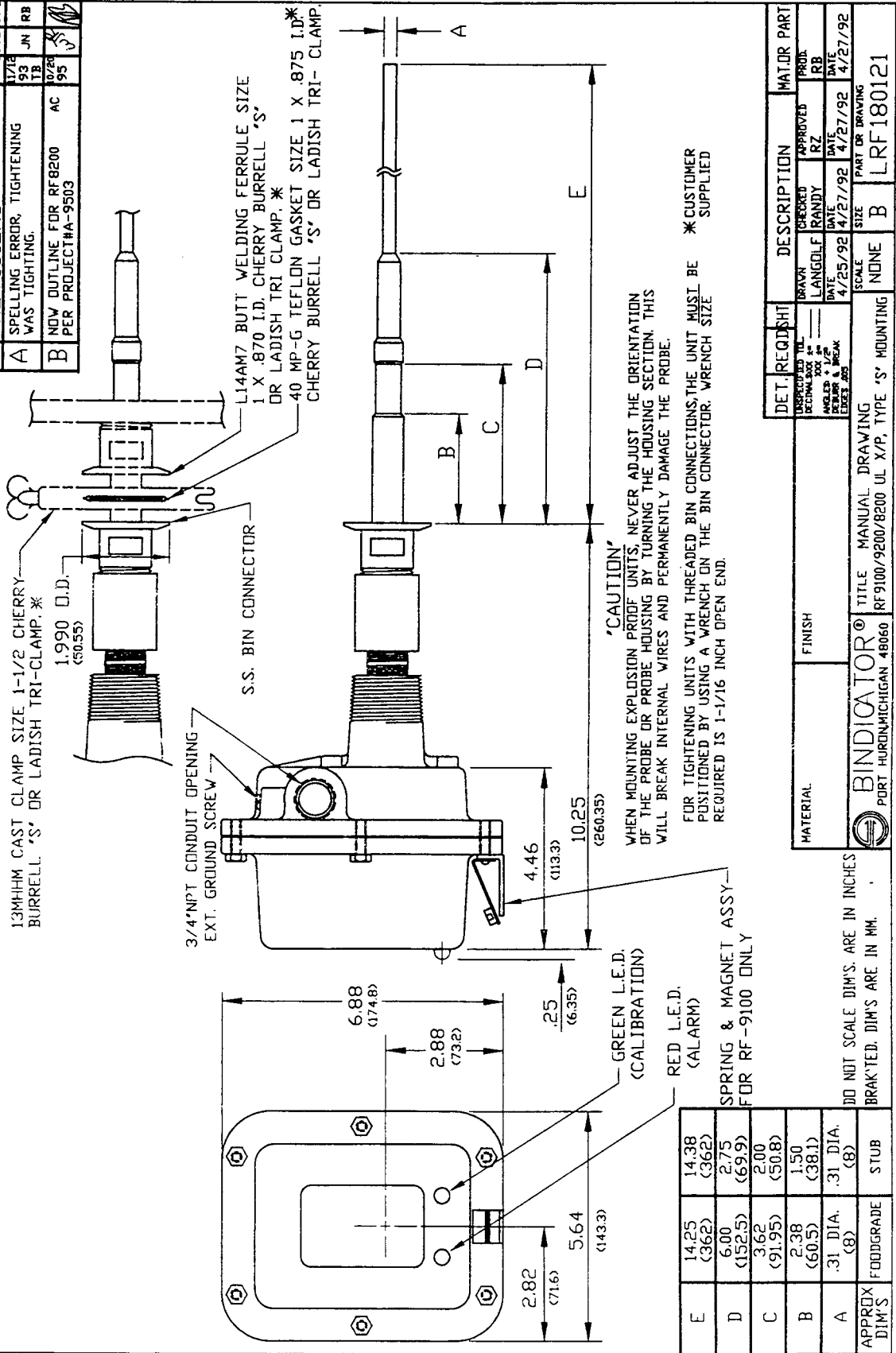

APPROX DIM'S	FOODGRADE	STUB
E	14.25 (362)	14.38 (362)
D	6.00 (152.5)	2.75 (69.9)
C	3.62 (91.95)	2.00 (50.8)
B	2.38 (60.5)	1.50 (38.1)
A	.31 DIA. (8)	.31 DIA. (8)

DET REQ'D	DRWG	APPROVED	MAT. OR PART
DESIGNED BY	LANGOLF	RZ	PROD.
CHECKED BY	RANDY	RZ	RB
DATE	4/25/92	DATE	4/27/92
SCALE	NONE	SCALE	B
PART OR DRAWING	LRF180121		

MATERIAL	FINISH	TITLE	MANUAL DRAWING
		RF9100/9200/8200 UL X/P, TYPE 'S' MOUNTING	

BINDERATOR®		PORT HURON, MICHIGAN 48060	
DO NOT SCALE DIM'S. ARE IN INCHES BRACKETED DIM'S ARE IN MM.			

REVISIONS		DATE	BY	APP'D
A	SPELLING ERROR, CUSTOMER WAS CUSTOMER	93	JN	RB
B	NOW OUTLINE FOR RF8200 PER PROJECT #A-9503	10/24/95	JA	RB

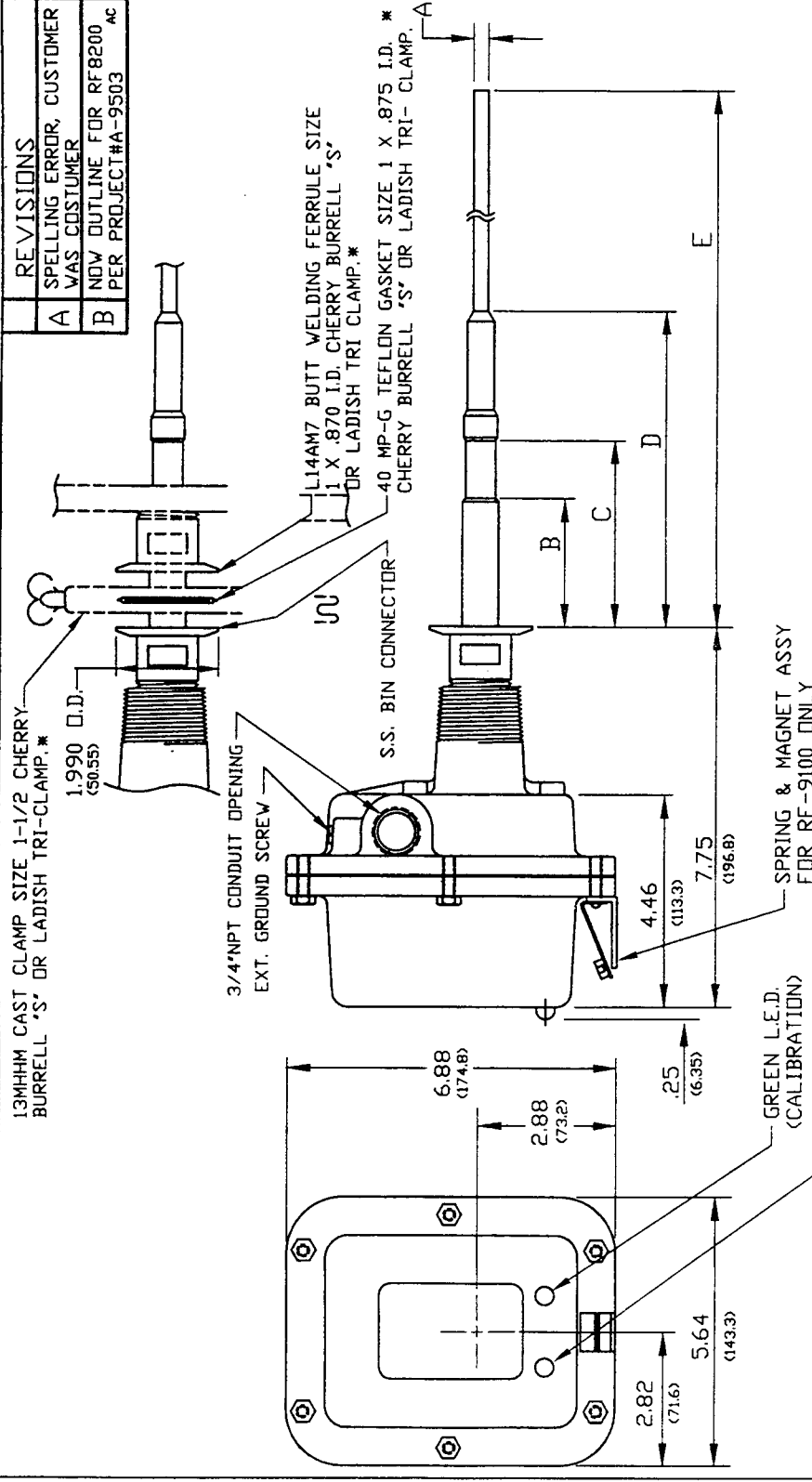

APPROX DIM'S	FODDGRADE	STUB
E	14.25 (362)	14.25 (362)
D	6.00 (152.4)	2.75 (69.9)
C	3.62 (91.95)	2.00 (50.8)
B	2.38 (61.5)	1.50 (38)
A	.31 DIA. (8)	.31 DIA. (8)

* CUSTOMER SUPPLIED

DO NOT SCALE DIM'S ARE IN INCHES
BRACKETED DIM'S ARE IN MM.

DET. REQUEST	DESCRIPTION	MATERIAL	PART
UNSPECIFIED TOL. RECOMMENDED ANGLES & 1/P. EXCEEDS	DRAWN BY LANGOLF RANDY	APPROVED BY RB	PROD. RB
DATE 4/25/92	DATE 4/27/92	DATE 4/27/92	DATE 4/27/92
SCALE NONE	SIZE B	PART OR DRAWING LRF180122	

BINDICATOR® TITLE MANUAL DRAWING
PORT HURON, MICHIGAN 48060 RF 9100/9200/8200 G/P, TYPE 'S' MOUNTING

REV	DATE	CHK'D	APP'D
A	10/20/95	VJR	R.B.
B	01/07/97	AC	AC

REVISIONS
 A NOW OUTLINE FOR RF8200 PER PROJECT #A-9503 AC
 B DWG REVISED TO SHOW NEW CASTING, ECO #96-101. DE

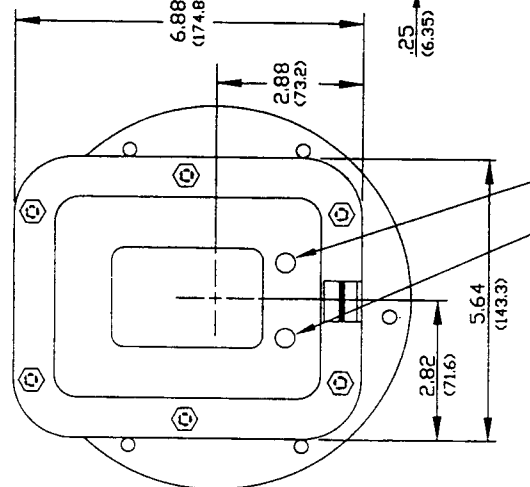
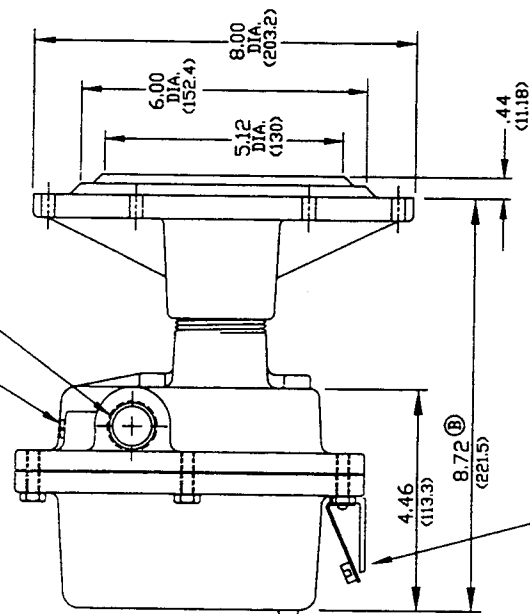
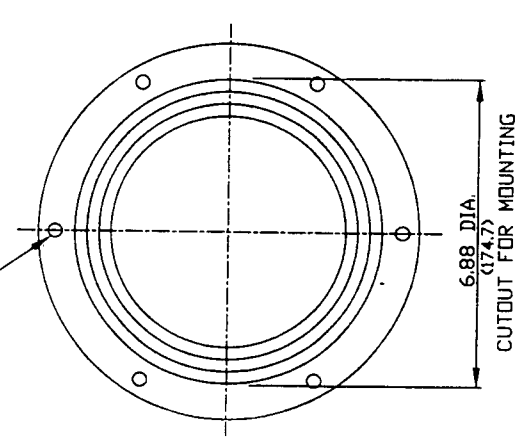

'CAUTION'
 WHEN MOUNTING EXPLOSION PROOF UNITS, NEVER ADJUST THE ORIENTATION OF THE PROBE OR PROBE HOUSING BY TURNING THE HOUSING SECTION. THIS WILL BREAK INTERNAL WIRES AND PERMANENTLY DAMAGE THE PROBE.
 THE POSITION MUST BE ADJUSTED BY REMOVING THE MOUNTING BOLTS AND MOVING THE ENTIRE PROBE AND HOUSING.

MOUNTING SURFACE PREPARATIONS
 1. LAY OUT TWO CONCENTRIC CIRCLES ON BIN WALL AT POINT WHERE THE RF LEVEL CONTROL IS TO BE MOUNTED. ONE CIRCLE TO BE 6-7/8" DIAMETER, THE OTHER 7-7/16" DIAMETER.
 2. CUT OUT 6-7/8" DIAMETER CIRCLE.
 3. LAY OUT SIX EQUALLY SPACED HOLES ON 7-7/16" DIAMETER CIRCLE. DRILL OR TAP FOR 1/4" BOLTS OR CAP SCREWS.

DET. REQD/SH	DESCRIPTION	MAT/DR PART
DRAWN BY: NEAL	CHECKED BY: RR	APPROVED BY: RB
DATE: 9/17/93	DATE: 9/21/93	DATE: 9/21/93
SCALE: NONE	SCALE: B	SCALE: LRF180123
TITLE: MANUAL DRAWING	TITLE: RF 9100/9200/8200 FLUSH PROBE GP/XP	TITLE: RF 9100/9200/8200 FLUSH PROBE GP/XP
 BINDERATOR® PORT HURON, MICHIGAN 48060		

REVISIONS		DATE	CK'D	APP'D
B	DWG. REVISION TO SHOW NEW CASTING, ECO #98-101.05	9/27/97	HL	

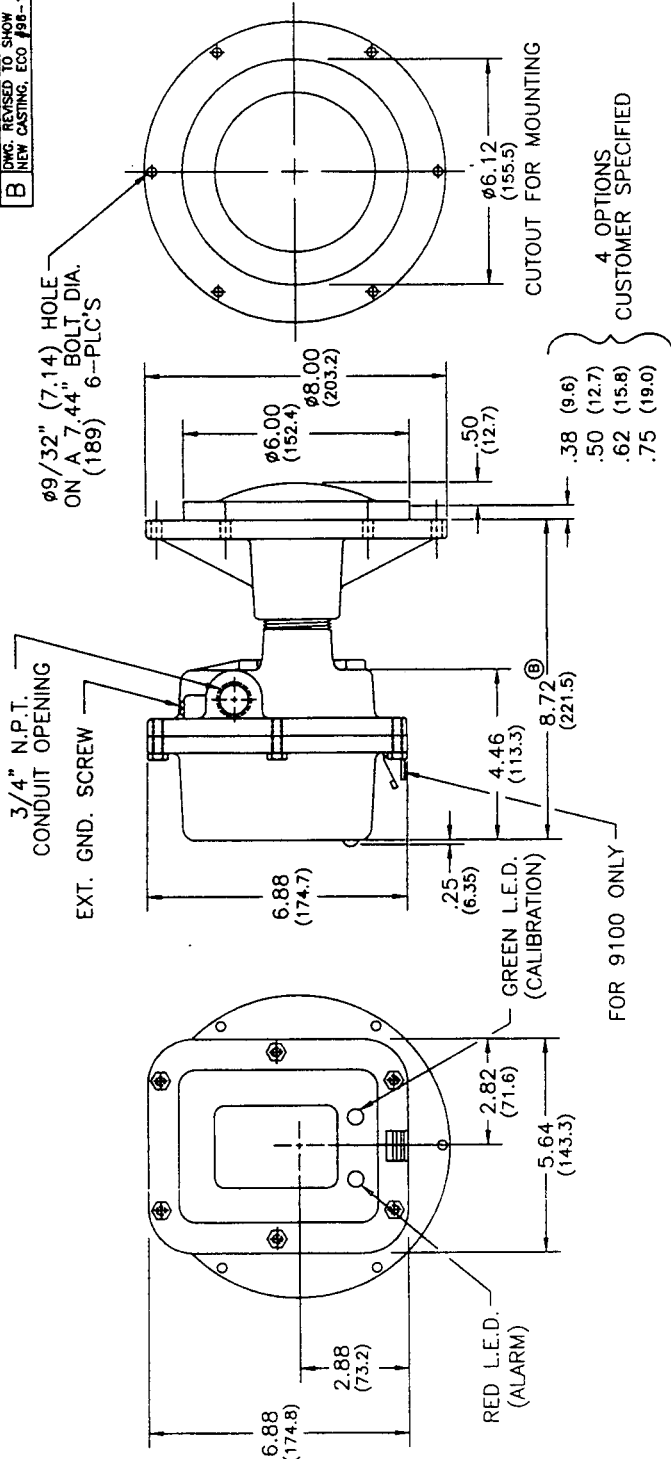

MOUNTING SURFACE PREPARATIONS

- LAY OUT TWO CONCENTRIC CIRCLES ON BIN WALL AT POINT WHERE THE RF LEVEL CONTROL IS TO BE MOUNTED. ONE CIRCLE TO BE 06-1/8", THE OTHER 07-7/16".
- CUT OUT 06-1/8" CIRCLE.
- LAY OUT SIX EQUALLY SPACED HOLES ON 07-7/16" CIRCLE. DRILL OR TAP FOR 1/4" BOLTS OR CAP SCREWS.

"CAUTION"
 WHEN MOUNTING EXPLOSION PROOF UNITS, NEVER ADJUST THE ORIENTATION OF THE PROBE OR PROBE HOUSING BY TURNING THE HOUSING SECTION. THIS WILL BREAK INTERNAL WIRES AND PERMANENTLY DAMAGE THE PROBE.

FOR "FLUSH PROBE" UNITS, THE POSITION MUST BE ADJUSTED BY REMOVING THE MOUNTING BOLTS AND MOVING THE ENTIRE PROBE AND HOUSING.

DO NOT SCALE DIM'S. ARE IN INCHES
 BRACKETED DIM'S. IN MM

DET. REQ'D/SHT	DESCRIPTION	MAT. OR PART
UNAPPROVED TOC	DRAWN	DRAWN
DESIGNED BY	REGENTIN LANGOLF	APPROVED
DATE	DATE	DATE
4/27/92	4/27/92	4/27/92
AMBER 1/2"		
CHECK & SIGN		
UNES. 205		
TITLE	MANUAL DRAWING GP/XP	PART OR DRAWING
RF9100/9200 DOME FLUSH PROBE	NONE	B
		SCALE
		NONE
		SIZE
		B
		LRF180124

BINDICATOR®
 PORT HURON, MICHIGAN 48060

REVISIONS		DATE	BY	CHK'D	APP'D
A	SPELLING ERROR I 1/4"	10/28/93	JN	RB	
B	ADD OUTLINE FOR RF8200 PER PROJECT #A-9503	10/28/93			

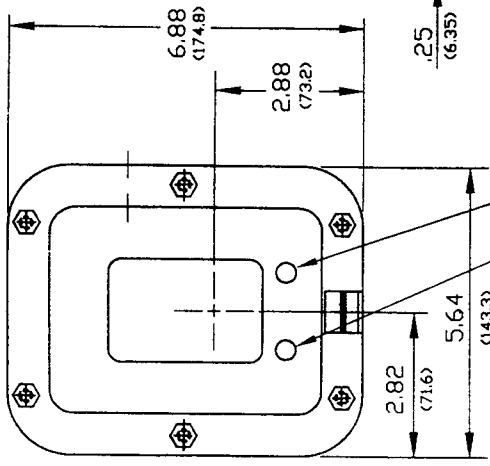
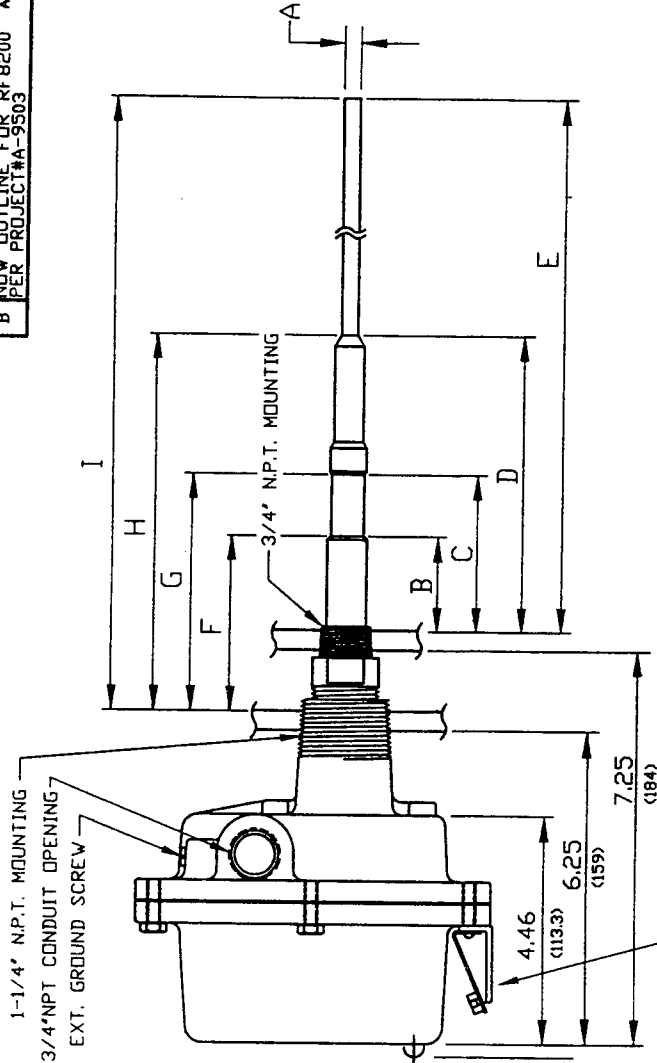

APPROX DIM'S	STD. & FODDGRADE	H.D.	STD. KYNAR H.D. KYNAR COATED	STD. KYNAR H.D. KYNAR COATED	STUB
I	15.25 (387.5)	19.62 (498.35)	15.62 (396.7)	15.62 (396.7)	15.25 (387.35)
H	7.00 (178)	7.00 (178)	7.00 (178)	7.00 (178)	7.00 (178)
G	4.50 (114.5)	4.50 (114.5)	4.50 (114.5)	4.50 (114.5)	4.50 (114.5)
F	3.38 (86)	3.38 (86)	3.38 (86)	3.38 (86)	3.38 (86)
E	14.25 (362)	14.25 (362)	14.25 (362)	14.25 (362)	14.25 (362)
D	6.00 (152.5)	6.00 (152.5)	6.00 (152.5)	6.00 (152.5)	6.00 (152.5)
C	3.50 (89)	3.50 (89)	3.50 (89)	3.50 (89)	3.50 (89)
B	2.38 (60.3)	2.38 (60.3)	2.38 (60.3)	2.38 (60.3)	2.38 (60.3)
A	.31 DIA. (7.9)	.31 DIA. (7.9)	.31 DIA. (7.9)	.31 DIA. (7.9)	.31 DIA. (7.9)

RED L.E.D. (ALARM)
GREEN L.E.D. (CALIBRATION)

SPRING & MAGNET ASSY FOR RF-9100 ONLY

DO NOT SCALE DIM'S. ARE IN INCHES
BRACKETED DIM'S ARE IN MM.

DET. REQ'D	SHIT	DESCRIPTION	MATERIAL PART
UNSPECIFIED TOL.	DRAWN	(CHECKED)	APPROVED
ASSEMBLY	NEAL	EP	RR
WELDER & V.P.	DATE	DATE	DATE
ENTER ASS.	9/11/93	9/13/93	9/13/93

TITLE	MANUAL DRAWING	SCALE	SIZE	PART OR DRAWING
RF9100/9200/8200 UL		NDNE	B	LRF180131

BINDICATOR®
PDRT HURONMICHIGAN 48060

REVISIONS		DATE	BY
B	CONVERTED TO DL2 ELEC. PER ECD 894-126	8/19/94	S.H. R.B.
C	ALTERED HOOKUP WITH DC LABELING. ECD# 95-108	8/28/95	

GREEN CALIBRATION L.E.D.

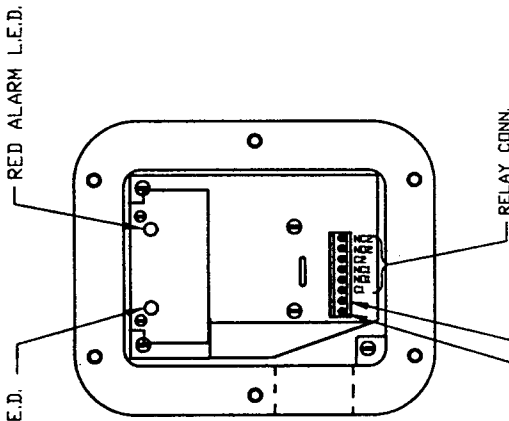

RELAY CONN.
(SEE FIG. 1)

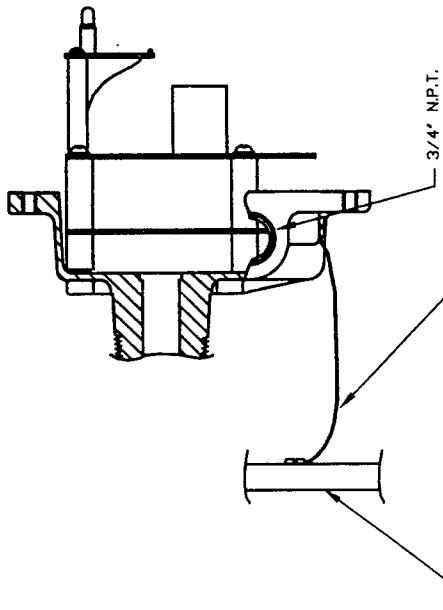

VESSEL WALL

EXTERNAL GRD. SCREW
(SEE NOTE 3)

3/4" N.P.T.
CONDUIT OPENING

AC UNITS ARE MARKED NEU
DC UNITS ARE MARKED +VDC

- NOTE: 1) FIELD WIRING SHALL BE ACCORDING TO LOCAL STD.
2) POWER TO UNITS (TYPE) 18 AWG MINIMUM RECOMMENDED.
3) ATTACHING GRD. WIRE FROM EXT. GRD. LUG ON RF UNIT TO VESSEL IS THE PREFERRED METHOD OF GROUNDING THE UNIT.
4) ON X/P UNITS, EXPLOSION PROOF SEAL FITTING MUST BE INSTALLED WITHIN 18" OF CONDUIT OPENING.

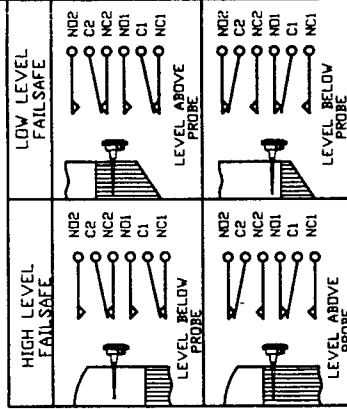

FIGURE 1

DET. REQSHT		DESCRIPTION		MATERIAL PART	
DESIGN	REV	CHECKED	APPROVED	PROB.	
DATE	DATE	DATE	DATE	DATE	DATE
9/11/93	9/13/93	9/13/93	9/13/93	9/13/93	9/13/93
SCALE	SCALE	PART OR DRAWING			
NDNE	B	LRF180132			

DO NOT SCALE DIMS. ARE IN INCHES

MATERIAL FINISH

BINDICATOR®
PDRT. HURON MICHIGAN 48060

TITLE
RF 9100/9200 CUSTOMER HOOKUP DWG DL2

REVISIONS		DATE	BY
A	1.625 DIM. WAS 6.50 PER ECOM98-1492	12/4/94	SP

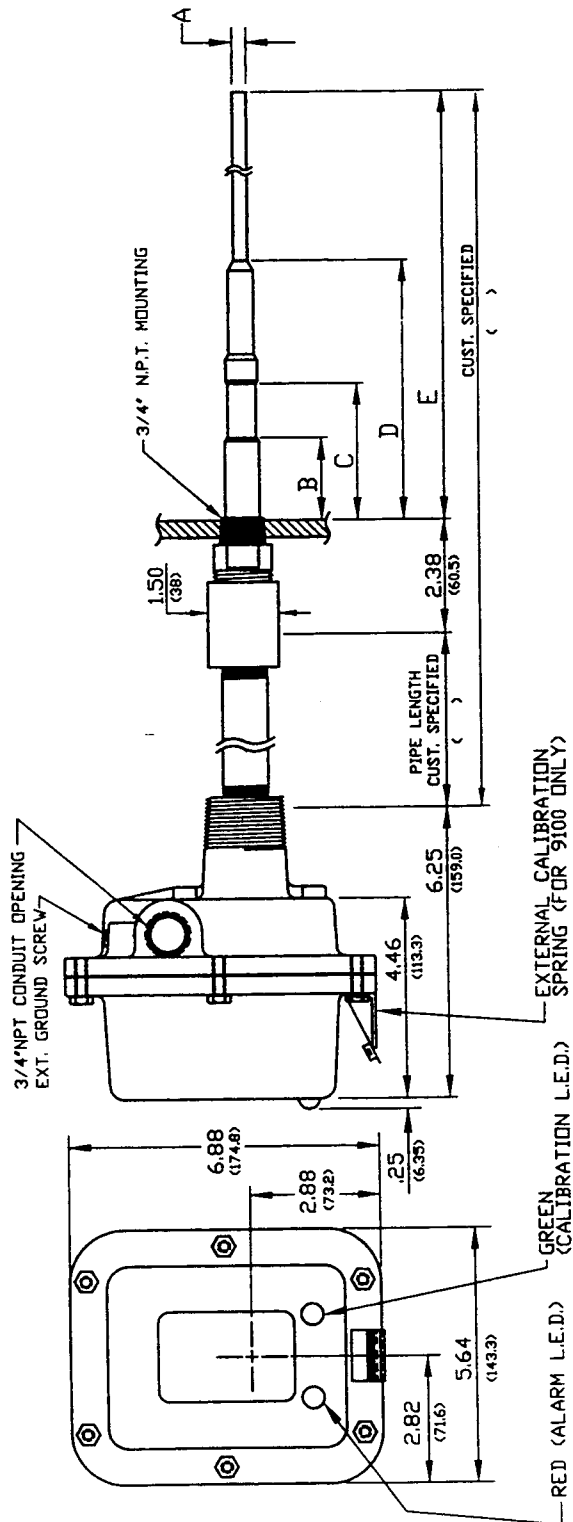

APPROX DIM'S	STD. & FOODGRADE	H.D.	STD. KYNAR COATED	H.D. KYNAR COATED	STUB
A	.31 DIA.	.38 DIA.	.31 DIA.	.38 DIA.	.31 DIA.
B	1.75	1.50	1.50	1.50	1.75
C	2.25	2.38	2.38	2.38	2.25
D	2.63	2.75	2.75	2.75	2.63
E	14.25	14.62	14.62	14.62	14.25

DO NOT SCALE DIM'S. ARE IN INCHES
BRACKETED DIM'S ARE IN MM

DET REQ	REQSHT	DESCRIPTION	MATERIAL	FINISH	SCALE	TITLE	MANUAL DRAWING
DRWN	CHKD	APPROVED	DATE	DATE	DATE	DATE	DATE
9/23/94	9/27/94	9/28/94	9/28/94	9/28/94	9/28/94	9/28/94	9/28/94
SIZE	NONE	B	LRF180162				

BINDICATOR®
PORT HURON, MICHIGAN 48060

REVISIONS

DATE: 8/1/97

BY: J.P.P.

1-1/4" N.P.T. MOUNTING
3/4" NPT CONDUIT OPENING
EXT. GROUND SCREW

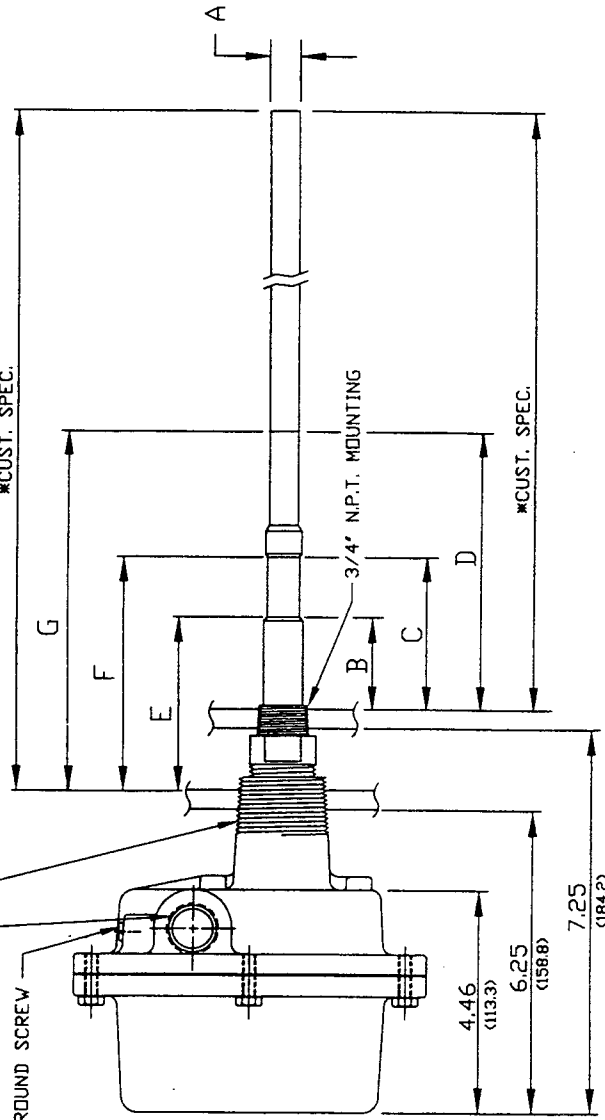
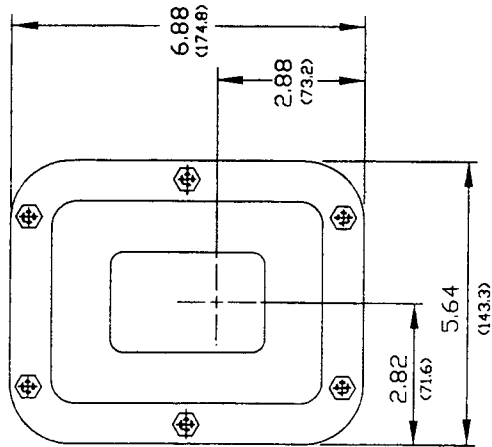

*CUST. SPEC.

*CUST. SPEC.

- *STANDARD LENGTH/ND TIP EXTENSION
- 1) 14.63(371.6) FOR 3/4" N.P.T. MOUNT
- 2) 16.00(406.4) FOR 1-1/4" N.P.T. MOUNT
- *HEAVY DUTY LENGTH/ND TIP EXTENSION
- 1) 18.38(466.4) FOR 3/4" N.P.T. MOUNT
- 2) 19.75(501.7) FOR 1-1/4" N.P.T. MOUNT

DO NOT SCALE DIM'S. ARE IN INCHES
BRAK'TED. DIM'S ARE IN MM.

G	7.00 (177.8)	11.75 (298.5)
F	4.50 (114.3)	10.00 (254.0)
E	3.50 (88.9)	8.50 (215.9)
D	6.00 (152.4)	10.75 (273.1)
C	3.00 (76.2)	9.00 (228.6)
B	2.38 (60.3)	7.50 (190.5)
A	.64 DIA. (16.3)	.64 DIA. (16.3)
APPROX DIM'S	STD.	H.D.

MATERIAL	FINISH	UNSPECIFIED TOL.	DRAWN	CHECKED	APPROVED	PROD.	MARKET.
		TECHNICAL ANGLES & V.P. LEADER LINES	DATE	DATE	DATE	DATE	DATE
			8/15/97	8/15/97	8/15/97	8/15/97	8/15/97
TITLE		DRAWING		SCALE		PART OR DRAWING	
RF 9000 G/P		RF 9000 & MOUNTING		NONE		B	
		V/TEFLON COATED PROBE				LRF 180201	

GENERAL TERMS AND CONDITIONS OF SALE

- 1. PAYMENT** Terms of payment are Net 30 days and are effective from the actual date of invoice. If, in the Seller's opinion, the financial condition of the Buyer at any time—or any other circumstances do not justify the incurrence of production costs or shipment on the terms of payment specified, the Seller may require partial or full payment in advance.
- 2. F.O.B.** All shipments are F.O.B. Seller's factory in Port Huron, Michigan, unless otherwise stated in the quotation.
- 3. QUOTATION AND PRICES** Quoted prices are firm for thirty days and are subject to change without notice after expiration of this period. Orders calling for future deliveries will be invoiced according to prices in effect at the time of shipment.
- 4. TAXES** Any applicable sales, use, revenue, excise or other taxes not specifically stated in the quotation are to be remitted by the Buyer directly to the appropriate regulatory agency.
- 5. EQUIPMENT WARRANTY/LIMITATION** The following BINDICATOR products are warranted for a period of two years from date of shipment against defective materials and workmanship: RF Series, Mark III Yo-Yo, General Purpose Yo-Yo, Micro-Sonic Series, Eagle, Mach One, Leveldata, Tracker, and Levelite Series. All CELTEK and other Bindicator products are warranted for a period of one year from date of shipment against defective materials and workmanship. WE MAKE NO OTHER WARRANTY, EXPRESS OR IMPLIED, AND ANY WARRANTY OF MERCHANTABILITY OR FITNESS FOR A PARTICULAR PURPOSE WHICH EXCEEDS THE FOREGOING IS HEREBY DISCLAIMED AND EXCLUDED FROM THIS CONTRACT. If the products are being acquired for resale, Buyer will make, in connection with any such resale, only those warranties contained herein and will indemnify us against any claims, causes of actions and judgments which arise from any representations, warranties or agreements made by or entered into by Buyer, other than those contained herein.
- 6. BUYER'S EXCLUSIVE REMEDY** In the event of any breach of warranty, the sole and exclusive remedy of Buyer (or any person claiming through Buyer) shall be limited to the repair or replacement of defective products or parts, at our plant or at Seller's option, to the refund of the purchase price, provided that notice of such defects is given within six months after shipment. In no event will our liability include any incidental or consequential damages.
- 7. DELIVERY** The Seller shall not be liable for loss or damage of any kind resulting from delay or inability to deliver or account of flood, fire, strike, labor troubles, riot, civil disturbances, accidents, acts or orders or regulations of civil or military authorities, shortages of materials, or any other cause or causes (whether or not similar in nature to any of these enumerated) beyond Seller's control.
- 8. PRODUCT CHANGES** In keeping with our continuing policy of product improvement, we reserve the right to make changes in our products at any time, without incurring an obligation to change equipment previously shipped.
- 9. RETURN OF GOODS** In no case may products or parts be returned without Seller's prior written permission. Products or parts returned under the aforementioned Equipment Guarantee must be shipped with transportation charges prepaid. All other returns must be shipped with transportation charges prepaid and will be subject to a restocking charge. Only products of standard Bindicator manufacture will be accepted for return. Products which are specially modified or produced to the Buyer's specifications will not be accepted for return.
- 10. CONTRACT FORMATION** A binding contract shall not be effective until a written purchase order is received at Seller's office in Port Huron, Michigan and accepted in writing by an authorized employee of the Seller at its Port Huron office. The terms and conditions in our quotation or acknowledgment shall govern the contract and any different or additional terms in Buyer's purchase order, unless approved by Seller in writing, are hereby objected to.
- 11. CONSTRUCTION** Any agreement arrived at shall be considered to be a Michigan contract and shall be construed under the laws of the State of Michigan.
- 12. CANCELLATION** Request for cancellation must be in writing and referred to Bindicator. No orders will be accepted with the understanding that they may later be cancelled. If and when cancellation is approved by Bindicator, it is with the understanding that Bindicator will be fully reimbursed by payment of cancellation charge: which are to be determined by Bindicator.
- 13. CERTIFICATION OF NONSEGREGATED FACILITIES** Our firm does not maintain facilities of a segregated nature contrary to the provision of 41 CFR 60-1.8, and further that if we have 50 or more employees and our contractual arrangements of \$50,000 or more we have complied with 41 CFR 60-1.7 concerning the annual filing of a report on Standard Form 100 (EEO-1) and with 41 CFR 60-1.40 by developing a written Affirmative Action Compliance Program.



150 Venture Boulevard
Spartanburg, SC 29306
Phone: (864) 574-8060, Fax: (864) 574-8063
Customer Service: (800) 778-9242
Internet: www.bindicator.com
Email: sales@bindicator.com