

MVS-Modbus Installation and Operation Manual

CAUTION

It is essential that all instructions in this manual be followed precisely to ensure proper operation of the equipment.

NOTICE

The content of this document is the intellectual property of Kistler-Morse Corporation. Any reproduction or translation of this document without the written authorization of a Kistler-Morse corporate officer is prohibited.

This manual reflects MVS software revision 'L' and MVS-Modbus software revision 'E.' If you have a previous revision(s), contact Kistler-Morse.

Revision Description

Following is a description of the major differences between Revision New and Revision A of this manual:

- References to the SVS 2000, which can now interface with the MVS-Modbus, were added to the manual.
- Chapter 3 — Revision K and later MVS software eliminated the need to enter the KM Mfg Code to access the *Add* and *Del* Menus. The manual was updated to correspond. A note was added explaining that the KM Mfg Code is required for older versions of the product.

Following is a description of the major differences between Revision A and Revision B of this manual:

Updated KM logo.

Following is a description of the major differences between Revision B and Revision C of this manual:

Updated to add ultra-wave™ Ultra-sonic system.

Table of Contents

Revision Description	Rev-1
Chapter 1. Introduction	1-1
Introduction	1-1
Multi-Vessel System	1-1
Modbus Interface (MVS-Modbus)	1-1
Data Organization	1-1
Modes of Operation	1-2
Modbus Function Codes	1-2
MVS Physical Description	1-3
Using MVS Display and Keyboard	1-4
Auto/Man Key	1-4
Up and Down Arrow Keys	1-5
Tare/Net/Gross Key	1-5
Menu Key	1-5
F1, F2, and F3 Keys	1-5
Esc Key	1-5
⇐ (backspace) Key	1-5
Shift Key	1-6
Enter Key	1-6
‘.’ (Period) Key	1-6
Alphanumeric Keys	1-6
Manual Conventions	1-6
Chapter 2. Hardware Setup.....	2-1
Introduction	2-1
MVS-Modbus PCB	2-1
MVS-Modbus Termination PCB	2-1
Installing Additional MVS-Modbus PCBs in MVS	2-1
Alignment Key Placement	2-1
MVS-Modbus PCB Installation	2-2
Chapter 3. Setting Up the MVS-Modbus	3-1
Introduction	3-1
Setting Up MVS to Recognize MVS-Modbus PCB	3-1
Adding and Deleting MVS-Modbus Channels	3-4
Setting Up MVS-Modbus PCB to Interface with Modbus-Compatible Device	3-5
Resetting MVS-Modbus PCB to Default Parameters	3-8
Channel Report	3-8
Chapter 4. Programming	4-1
Introduction	4-1
Modes of Operation	4-1
Data Structure	4-1
Control Mode Miscellaneous System Commands	4-6
Chapter 5. Commands for MVS-Modbus/ MVS ADC, Setpoints, and Current Outputs.....	5-1
Chapter Contents	5-1

Chapter 6. Commands for MVS-Modbus/ Sonologic 5000 Series-ITU-SSU	6-1
Chapter 7. Commands for MVS-Modbus/ ITX Belt Scale Integrator	7-1
Chapter 8. Commands for MVS-Modbus/ STX Signal Transmitter	8-1
Chapter 9. Commands for MVS-Modbus/ Models 1000 and 1020.....	9-1
Chapter 10. Commands for MVS-Modbus/Sono II & U-W	10-1
Chapter 11. Commands for MVS-Modbus/Weigh II	11-1
Chapter 12. Commands for MVS-Modbus/SVS 2000	12-1
Appendix A. Kistler-Morse Service and Warranty	A-1
Product Warranty	A-1
Service	A-1
Return Material Authorization	A-2
Address and Telephone Numbers	A-2
Appendix B. Technical Drawings	B-1

Chapter 1. Introduction



Half-Rack MVS
(MVS-4D)



19" Rack MVS (MVS-8D)

Figure 1-1. Multi-Vessel Systems

Introduction

This manual covers the setup and program commands for interfacing the Kistler-Morse Multi-Vessel System™ (MVS) with a Modbus™-compatible device via a Modbus Remote Terminal Unit (RTU) serial link.

Refer to Chapter 2, Hardware Setup, for MVS-Modbus hardware installation and setup procedures. MVS-Modbus parameters such as data type, mode, serial address, baud rate, stop bits, parity, and starting index are set up by using the MVS menu. Using the MVS menu is described in Chapter 3, Setting Up the MVS-Modbus. Refer to Chapter 4, Programming, for programming instructions.

Multi-Vessel System

The MVS, shown in Figure 1-1, is a multi-channel signal processing and display system that receives analog and digital serial inputs. The MVS monitors and displays material information for the following:

- Strain gage sensors/transducers connected to the MVS ADC Printed Circuit Board (PCB)
- Strain gage sensors/transducers connected to the MVS STX Signal Transmitter PCB; STX signal processors communicating serially with the MVS

- Belt scale monitoring sensors connected to the MVS ITX Integrator PCB; ITX signal processors communicating serially with the MVS
- Sonologic 5000 series-Intelligent Transceiver Units (ITUs)-Sensor Switching Units (SSUs) ultrasonic signal processors communicating serially with the MVS
- 1000/1020 weight indicators communicating serially with the MVS
- Sonologic II® & ultra-wave™ ultrasonic signal processors communicating serially with the MVS
- Weigh II weight indicators communicating serially with the MVS
- SVS 2000™ weight indicators communicating serially with the MVS
- Slave MVS

Installation, setup, and calibration of the MVS and the sensors should be done before using this manual to set up the Modbus serial link (refer to the *MVS Installation and Operation Manual*).

Modbus Interface (MVS-Modbus)

The Modbus Interface (i.e., MVS-Modbus) was developed by K-M to provide an interface between K-M level, weight, and flow measurement systems and Modbus-compatible devices.

Note

The MVS-Modbus PCB installs in a card slot in both the MVS-8D and the MVS-4D. Rev. E of the MVS-Modbus firmware supports all the listed signal processors.

Data Organization

Information passed between the MVS and a Modbus device is placed in blocks of registers on the MVS-Modbus PCB. The register blocks emulate the holding registers of a PLC to provide a memory map for the exchange of data.

The MVS-Modbus registers are organized into two contiguous blocks, one for command inputs from a Modbus master device and one for MVS channel data output. During setup of the MVS-Modbus parameters, MVS channels designated for Modbus interface are assigned specific register locations in each block.

A Modbus master device may retrieve MVS signal processor data from the MVS-Modbus output register block and send command and data words to the MVS-Modbus input register block via the Modbus link.

The MVS integrates data acquired from signal processor modules installed in the MVS backplane and from remote serial devices. The MVS microprocessor PCB periodically scans the MVS-Modbus input block for commands from the Modbus master device and updates the Modbus output register block with data.

Modes of Operation

The MVS-Modbus operates in one of two modes: Control or Monitor.

See Figure 1-2. Control Mode operation requires the Modbus master device to write command and data words to the MVS-Modbus input register block with Modbus function codes 06H (preset single register) or 10H (preset multiple registers). The MVS-Modbus processes the command and updates the output registers with a data word and a command echo word. The master device may then read the data and command echo words from the Modbus output register block with Modbus function code 03H (read holding registers). The MVS-Modbus processes channel commands 1 and 2 for every signal processor data acquisition

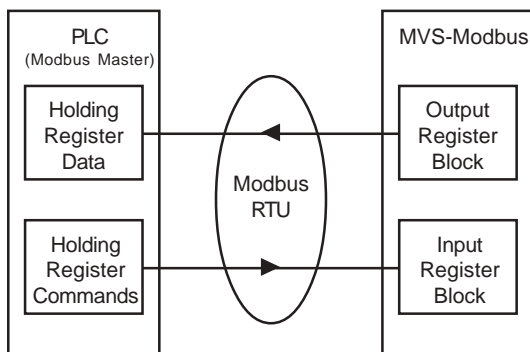

Figure 1-2. MVS-Modbus Interface Block Diagram: Control Mode

cycle of a channel while these commands remain in the command input register block. Command 1 and Command 2 (where applicable) provide the monitoring information from the signal processor, such as gross weight, net weight, level, or flow, as applicable. See Chapters 5 through 12 for specific parameters returned by Commands 1 and 2 for each signal processor. The remaining commands in a channel's command set are executed only once upon initial receipt and no other commands are processed until a new (different) command for that channel is sent.

See Figure 1-3. In Monitor Mode operation the MVS-Modbus places data words of a predefined type into the MVS-Modbus output register block, which can then be read by the master device with Modbus function code 03H (read holding registers). No command inputs from the master device are processed in Monitor Mode. The output registers are updated during every MVS-Modbus channel scan. The pre-defined types are Data1 and Data2, which correspond to the data from Control Mode Commands 1 and 2, respectively. For example, looking at the Quick Command Reference Table for MVS-Modbus/MVS ADC PCB in Chapter 5, Control Mode Command 1 returns the gross weight and Control Mode Command 2 returns the net weight. Therefore, Monitor Mode Data1 returns the gross weight while Monitor Mode Data2 returns the net weight. The selection of Data1 or Data2 is described in Chapter 3, Setting Up the MVS-Modbus.

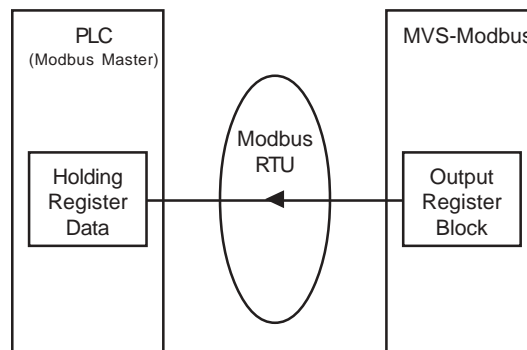

Figure 1-3. MVS-Modbus Interface Block Diagram: Monitor Mode

Modbus Function Codes

The holding registers of a Modbus device are 16 bits in length and have a starting index range of 40,001-49,999 (decimal). The MVS-Modbus supports Modbus function codes for Read and Write commands as shown in Table 1-1.

Function Code (Hexadecimal)	Description
03	Read holding register(s)
06	Write single register
10	Write multiple register(s)

Table 1-1. Modbus Function Codes

The MVS-Modbus is a slave device. All commands are issued in a continuous stream of 8-bit binary characters with the appropriate number of start, stop, and parity bits. This is followed by a silent interval of 3.5 character lengths (minimum) before the next query or response.

MVS Physical Description

There are two types of MVSs available: the MVS-8D with the industry-standard 19-inch rack and the MVS-4D with a NEMA-rated enclosure for wall and panel mounting. Figure 1-1 illustrates both types.

The MVS-8D consists of a rack(s) that holds a microprocessor PCB, a power supply, and up to eight optional, modular PCBs. The rack is designed to mount on a frame in a control room environment and has a backplane PCB. The modular PCBs slide into the rack and plug into connectors on the front of the backplane. Each modular PCB has a corresponding termination board PCB. The termination boards mate to the rear of the backplane, opposite the corresponding modular PCBs, and accept the wires from the sensors, peripheral equipment, etc. The MVS-Modbus termination board accepts the Modbus multidrop signal cable.

The MVS-4D's NEMA-rated enclosure is usually wall-mounted and is designed to be wired from the front. The rack inside the enclosure has four available card slots for optional, modular PCBs and a backplane PCB with connectors that extend below the rack and face forward. Termination boards plug onto these connectors and are accessed

through the front of the enclosure. The termination boards accept the wires from the sensors, peripheral equipment, etc. The MVS-Modbus termination board accepts the Modbus multidrop signal cable. The modular PCBs slide into the rack and plug onto the backplane the same as for the MVS-8D.

The PCBs available to make up an MVS are:

- Modbus Interface PCB (MVS-Modbus)
- Microprocessor PCB with RS-232/RS-422/RS-485 serial ports
- 8-channel ADC Strain Input PCB
- 8-channel Current Input PCB
- 8-channel Voltage Input PCB
- Regulator PCB
- 8-channel Current Output PCB
- 8-channel Relay Output PCB
- 1-channel STX PCB (MVS-STX)
- 1-channel ITX PCB
- Remote Tare PCB
- Allen-Bradley Remote I/O Interface PCB (MVS-RIO)

The modular PCBs are easily inserted and removed from the rack(s), so the MVS can be configured to address the needs of a particular application.

Every MVS must have a Microprocessor PCB and a Keyboard/Display panel. Other PCBs can be added as needed, depending on the auxiliary equipment used with the system. Additional racks of PCBs can be interfaced to the rack with the Microprocessor PCB.

The following K-M signal processors can be connected serially with RS-422A/RS-485:

- Stand-alone STX Signal Transmitter
- Stand-alone ITX Belt Scale Integrator
- Model 5000 Sonologic level indicator
- Model 5100 Sonologic Dual level indicator
- ITU Sonologic Intelligent Transceiver Unit
- SSU Sonologic Sensor Switching Unit (8 Channel)
- 1000/1020 weight indicator
- Sonologic II & ultra-wave™ signal processor
- Weigh II weight indicator
- SVS 2000 weight indicator
- Slave MVS — a Modbus-compatible device can only read level/weight/flow data from a slave MVS. Calibration data, setpoints, current outputs, etc. cannot be read or modified.

A Display/Keyboard panel is the same on both the MVS-4D and MVS-8D. On the MVS-8D, the Display/Keyboard panel is hinged to the front of the rack and swings down for easy access to the PCBs. On the MVS-4D, the Display/Keyboard panel is on the hinged front door of the enclosure. The display is a digital, backlit LCD and provides two lines of 16 digits in an alphanumeric format. The display can show monitoring information in a bar graph format as well as in alphanumeric form. The keyboard is used to access functions during operation and input parameter values during setup and calibration. The following section explains in detail the use of the display and keyboard.

Using MVS Display and Keyboard

The MVS Display/Keyboard Panel (Figure 1-4) has a liquid crystal display (LCD) with two 16-character lines. The LCD displays the vessel ID, material weight numerically or in bar graph format, menu selections, and error messages.

The keyboard is used to access the menus, scroll through the channel monitoring display screens, and input setup and calibration parameters. The function of each key is described below.

Auto/Man Key

When channel monitoring, the MVS displays the factory-set ID (or customer-defined ID, if input) and material weight/level. The MVS can be set up to scroll automatically through the display screen for each channel (Auto Mode) or remain fixed on a selected channel (Manual Mode). The Auto/Man Key toggles between Auto and Manual Modes.

- When in Auto Mode, the display remains on one channel for a preset period of time before scrolling to the next channel. The Auto LED to the right of the LCD is illuminated when in Auto Mode.
- When in Manual Mode, the display remains fixed on a selected channel and must be scrolled manually with the Up or Down Arrow Keys to display information on another channel. The Auto LED is off when in Manual Mode.

The Auto/Man Key is also used to exit any function in the menu tree and return the display to channel monitoring in Manual Mode.

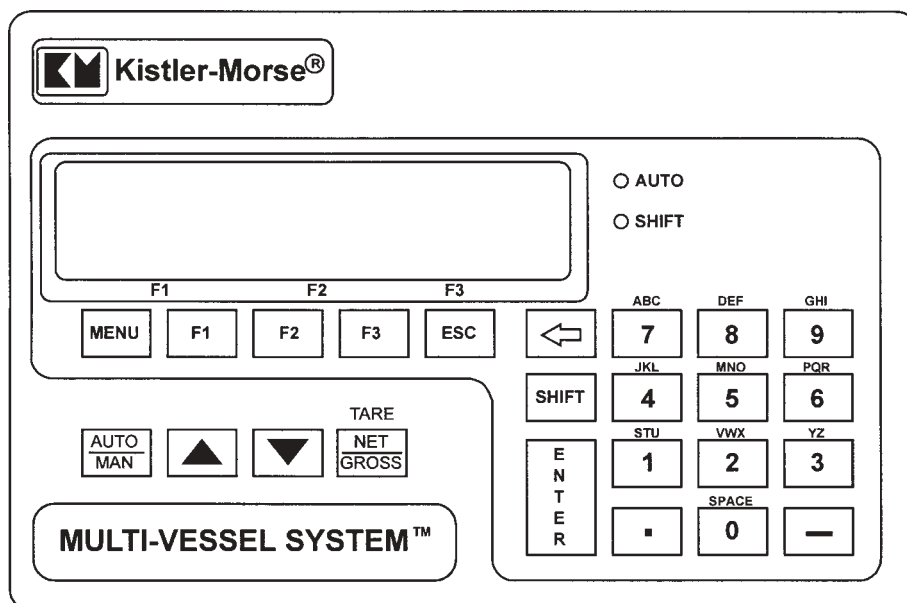

Figure 1-4. MVS Display and Keyboard

Up and Down Arrow Keys

The Up and Down Arrow Keys are used to manually scroll the display through the channels when channel monitoring in Manual Mode.

These keys are also used to scroll to desired values when in the menu tree, entering setup and calibration parameters. For example, when setting the *Lo Span* and *Hi Span* values in the *Auto Cal* Menu, the Arrow Keys can be used to scroll to a desired value.

Tare/Net/Gross Key

The Tare/Net/Gross Key is used when channel monitoring in Manual Mode (Auto LED off). This key works in conjunction with the Shift Key:

- Shift Key on (Shift LED illuminated) — The Tare Key is enabled. Pressing this key ‘tares’ the vessel on the display, setting the net value (for example, weight) to zero. The tare function is useful when you want to monitor how much material is added to or removed from the vessel from a given point.
- Shift Key off (Shift LED off) — The Net/Gross Key is enabled. Pressing this key toggles the display between the net value (weight added to or removed from the vessel since the last time the vessel was tared) and gross value (total weight of material in the vessel).

Menu Key

Note

The MVS must be channel monitoring in Manual Mode to access the menus.

Pressing the Menu Key accesses the *Main* Menu. If there are multiple pages to the menu, pressing the Menu Key again scrolls the display to the next page. For example, the *Main* Menu has two pages. Page 1 shows:

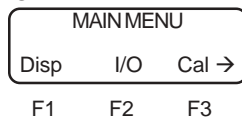

The → signifies there is a following page. Pressing the Menu Key again displays the second page:

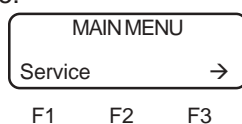

Note that the second page also has a → to indicate there are additional page(s) (in this case, you already viewed the other page). Pressing the Menu Key again returns the display to the first page.

The Menu Key has the same scrolling function when a submenu is accessed. Pressing the Menu Key scrolls through the pages of the submenu. Pressing the Esc Key backs through the submenus one level at a time and returns to the channel monitoring display.

F1, F2, and F3 Keys

The Function Keys — F1, F2, and F3 — are used to select the items on the menus. The faceplate has F1, F2, and F3 labeled underneath the LCD. When a menu is displayed, the menu items are located above these labels. Pressing the Function Key that corresponds to the desired selection provides access to the menu item. For example, when the *Main* Menu is displayed, the selections are:

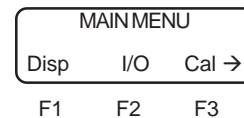

Disp is above the F1 label on the faceplate, *I/O* above F2, and *Cal* above F3. Pressing the F2 Key accesses the submenus under *I/O*.

Esc Key

The Esc Key has several functions:

- The Esc Key is used to back through the submenus one menu level at a time. Pressing this key while in the *Main* Menu returns the display to channel monitoring in Manual Mode.
- The MVS arrives from the factory with a factory-set ID number assigned to each channel. If you replaced the ID with a customer-defined ID in the *Disp* Menu, pressing the Esc Key while channel monitoring in Manual Mode (Auto LED off) briefly displays the factory-set ID.

⇐ (backspace) Key

The ⇐ Key is used to back up the cursor on the LCD display when using the alphanumeric keypad.

Shift Key

The Shift LED, located below the Auto LED on the faceplate, illuminates when the Shift Key is on. The Shift Key has several functions:

- The Shift Key is used in conjunction with the Alphanumeric Keys. When the Shift Key is on, the keypad types the letters labeled above the Alphanumeric Key (see Alphanumeric Keys below for information on toggling between the letters). When the Shift Key is off, the keypad types the number labeled on the key. The Shift Key is also used in conjunction with other keys on the panel to provide additional alphanumeric characters.
- The Shift Key is also used in conjunction with the Tare/Net/Gross Key.

Enter Key

The Enter Key has several functions:

- The Enter Key is used to save in memory any parameter set up in the menus. For example, if you enter a *Lo Span* value in the *Cal* Menu, pressing the Enter key saves it to memory. The value remains in memory until a new value is entered.
- When typing in a vessel ID, the Enter Key advances the cursor one space to the right.
- When the MVS is displaying gross values in Manual Mode, pressing the Enter Key toggles the display from numerical to bar graph format. The display remains in bar graph format (even when the MVS is turned off and back on again) until the Enter Key is pressed to toggle back to numerical format.

‘.’ (Period) Key

When the MVS is channel monitoring in Manual Mode, pressing the ‘.’ Key briefly displays the current MVS microprocessor card software revision letter and the date of the revision.

Alphanumeric Keys

The Alphanumeric Keys are used to type in numbers during setup and calibration.

When the Shift Key is on (Shift LED illuminated), the letters above the keys are accessed for use in inputting a customer-defined ID. Pressing an Alphanumeric Key repeatedly toggles the display through the three letters listed above the Key. When the desired letter is displayed, pressing the Enter Key or a different Alphanumeric Key advances the cursor one space to the right.

Manual Conventions

Three kinds of special explanations appear throughout the manual — **WARNING**, **CAUTION**, and *Note*. The format and significance of each is defined below:

WARNING

**Possible danger to people.
Injury may result if this information
is ignored.**

CAUTION

Possible risk to the product. The signal processor or other equipment may be damaged if this information is ignored.

Note

Contains additional information about a step or feature critical to the installation or operation of the signal processor.

Chapter 2. Hardware Setup

Introduction

The MVS-Modbus consists of two PCBs: the MVS-Modbus PCB that plugs into the MVS rack and the Termination PCB that plugs onto the MVS backplane opposite the MVS-Modbus PCB. This chapter describes how to connect the MVS-Modbus hardware to the Modbus RTU serial link and set jumpers on the PCBs for programming and operation.

MVS-Modbus PCB

Refer to TI-MP.MVSC-02 in Appendix B, Technical Drawings. Set the dipswitches S1, S3, S4, and S5 for RS-422, RS-232, or RS-485 as shown on the drawing.

MVS-Modbus Termination PCB

Note

When using RS-232, the Modbus does not support handshaking. If the master device requires handshaking, refer to the documentation for the Modbus device to configure the CTS and RTS lines.

Refer to TI-MP.MVSC-02 in Appendix B, Technical Drawings. The Termination PCB plugs onto the MVS backplane opposite the MVS-Modbus PCB. Connect the Modbus multidrop serial cable to TB2 for RS-232, RS-422, or RS-485 as shown on the drawing.

Installing Additional MVS-Modbus PCBs in MVS

The MVS arrives from the factory with the MVS-Modbus PCBs installed. However, you can expand your system by buying additional PCBs and installing them in vacant slots in the rack. This section describes how to install a PCB into the rack.

When you receive a new MVS-Modbus PCB from K-M, you should have the following items in the shipment:

- MVS-Modbus PCB
- Termination PCB
- Two 4-40 x 1/4 PHS screws to secure the Termination PCB to the MVS backplane
- Strip of alignment keys for MVS backplane connector
- PCB identification label

Alignment Key Placement

The J2 connector on the MVS-Modbus PCB and its mating MVS backplane connector accept removable alignment keys. The alignment keys are installed as a safeguard to prevent PCBs from being inserted into the wrong rack position. If the keys in the connectors do not align, the connectors cannot be plugged together.

CAUTION

Damage to the MVS may occur if a PCB is installed incorrectly.

The MVS-Modbus PCB and backplane connectors have twelve positions that accept alignment keys (labeled 'A' through 'I', 'K' through 'M'). The MVS-Modbus PCB arrives from the factory with its alignment keys in place.

The backplane connector must have alignment keys installed from the strip of keys provided in the shipping kit. Table 2-1 shows the positions of the keys. Break off as many keys as needed and insert the keys into the connector positions shown in the table.

MVS-Modbus PCB		
Key	Backplane	PCB
A	0	1
B	0	1
C	1	0
D	0	1
E	0	1
F	0	1
G	1	0
H	0	1
I	0	1
K	0	1
L	0	1
M	1	0

Legend: 1 = key in place; 0 = empty slot

Table 2-1. Location of Alignment Keys in MVS-Modbus PCB and Backplane Connector

MVS-Modbus PCB Installation

PCBs can go into any open rack position regardless of whether you have an MVS-8D or an MVS-4D. However, keeping the Setpoint PCBs to the right side of the rack and the MVS-Modbus and ADC PCBs to the left side is good policy.

Follow this procedure to install the MVS-Modbus PCB in the MVS:

1. Open the front of the MVS. Turn off power to the MVS.
2. Slide the MVS-Modbus PCB into the designated rack position. Be sure the PCB connector inserts completely into the backplane connector. Use the card extractor on the front of the PCB to secure it in place.
3. **MVS-8D** — plug the Termination PCB onto the rear of the MVS backplane opposite the MVS-Modbus PCB.
MVS-4D — plug the Termination PCB onto the backplane underneath the MVS-Modbus PCB.

4. Secure the Termination PCB in place with the two 4-40 x 1/4 PHS screws supplied in the shipment.
5. Place the self-adhesive label from the shipment (PCB identification) on the rack underneath the MVS-Modbus PCB.
6. Connect the field wiring to the Termination PCB.
7. Restore power to the MVS. Close the front panel. Installation is complete.
8. When you add a new MVS-Modbus PCB, you must perform the *RScn* (rescan) procedure to bring the new PCB on-line with the rest of the system. Refer to the section titled *Setting Up MVS to Recognize MVS-Modbus PCB* in Chapter 3, *Setting Up the MVS-Modbus*, for the *RScn* procedure.

Chapter 3. Setting Up the MVS-Modbus

Introduction

The MVS's menu tree is used to setup and calibrate the MVS. This chapter covers only the menus and submenus needed to set up the MVS-Modbus. Figure 3-1 is the menu tree for the MVS, with only those menu items applicable to the MVS-Modbus detailed. For a complete description of all MVS menu functions, refer to the *MVS Installation and Operation Manual*.

The *PLC* Menu is under the *I/O* Menu. Below this are five submenus:

- *Set* — sets up data type, mode, serial address, baud rate, stop bits, parity, and starting index
- *Reset* — resets nonvolatile EEPROM memory to default parameters (but does not delete assigned MVS-Modbus channels)
- *Rprt* — views MVS-Modbus channel numbers assigned to the current MVS channel
- *Del* — deletes MVS-Modbus channels previously assigned to the current MVS channel
- *Add* — assigns MVS-Modbus channels to the current MVS channel

Note

For older versions of this product, the *Del* and *Add* Menus appear only if you entered the K-M Mfg Code (9111).

The *Rscan* function is also needed to set up the MVS-Modbus. *Rscan* allows the MVS to recognize the address of any MVS-Modbus PCBs that you install (not required for factory-installed MVS-Modbus PCBs). *Rscan* is under *Micro* in the *Service* Menu.

The remaining sections of this chapter cover the use of these submenus in setting up the MVS-Modbus interface with the Modbus-compatible device.

Note

The screen displays shown in this chapter are for the MVS with an ADC PCB. There are small variations in the screen displays if accessing another device through the MVS. These variations include additional menu items which are not applicable to setting up the MVS-Modbus.

Setting Up MVS to Recognize MVS-Modbus PCB

Note

When the MVS arrives from the factory, it is set up to recognize the addresses of all factory-installed PCBs. If the MVS-Modbus PCB(s) was factory-installed, proceed to *Adding and Deleting MVS-Modbus Channels*.

See Figure 3-1. The *RScn* function allows the MVS to rescan addresses in the system. If you add MVS-Modbus PCBs to the MVS, follow this procedure **before proceeding with any other setup of the MVS-Modbus** so the MVS recognizes the MVS-Modbus PCB:

1. If in Auto Mode (Auto LED illuminated), press the Auto/Man Key to put the MVS in Manual Mode. The Auto LED turns off.
2. Press the Menu Key to display the *Main* Menu. The display shows:

```

MAIN MENU
Disp  I/O  Cal →
F1    F2    F3
  
```

3. Press the Menu Key to display the menu's second page. The display shows:

```

MAIN MENU
Service →
F1    F2    F3
  
```

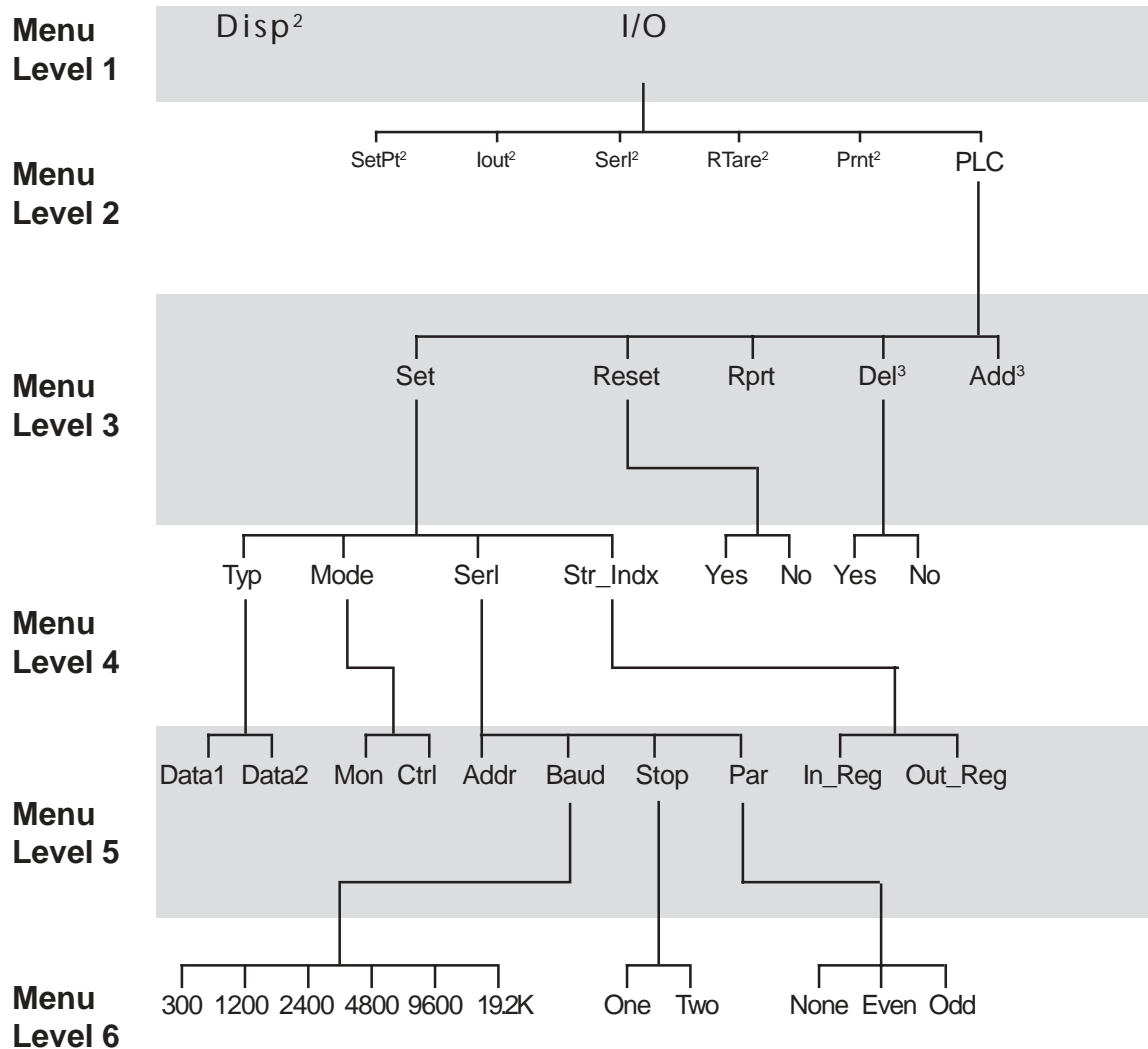

Notes:

1. The menu tree shown is for the MVS with an ADC PCB, with no other signal processors wired to the MVS. There may be small variations in the menu tree if accessing another device through the MVS.
2. See the *MVS Installation and Operation Manual* for information on these menus and any sub-menus, which are not needed to set up the MVS-Modbus.
3. For older versions of this product, the *Add* and *Del* Menus appear only if the K-M Mfg Code (9111) has been entered in the Service Menu.

Figure 3-1. MVS Menu Tree (continued on next page)

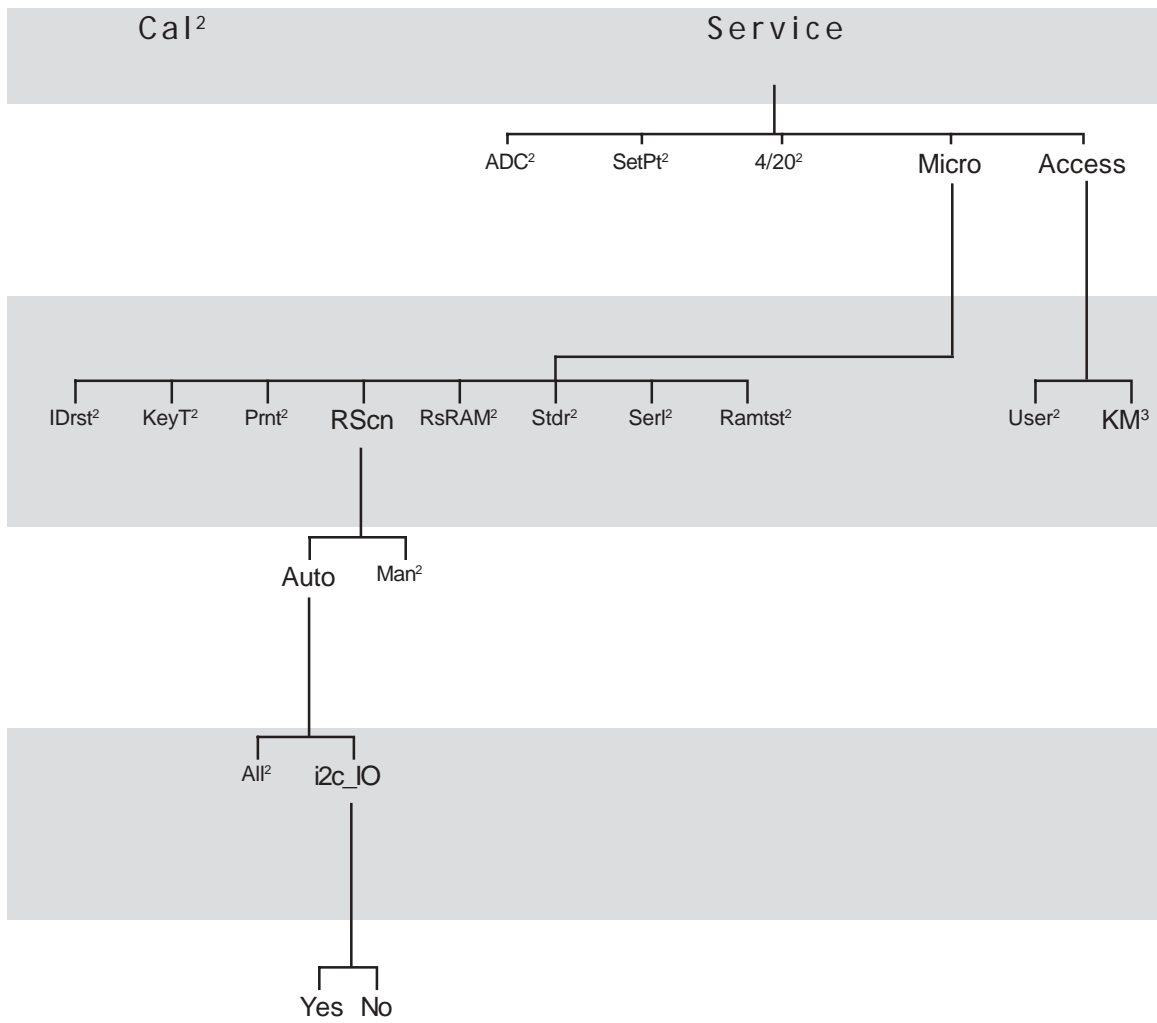

Figure 3-1. MVS Menu Tree (continued from previous page)

- Press the F1 Key to access the *Service* Menu. The display shows:

```

SERVICE ROUTINES
ADC SetPt 4/20→
F1   F2   F3
    
```

- Press the Menu Key to display the menu's second page. The display shows:

```

SERVICE ROUTINES
Micro      Access→
F1   F2   F3
    
```

- Press the F1 Key to access the *Micro* Menu. The display shows:

```

MICROFUNCTIONS
IDrst KeyT Prnt→
F1   F2   F3
    
```

- Press the Menu Key to display the menu's second page. The display shows:

```

MICROFUNCTIONS
RScn RsRAM Stdr→
F1   F2   F3
    
```

- Press the F1 Key to access the *RScn* Menu. The display shows:

```

RE-SCAN MENU
Auto      Man
F1   F2   F3
    
```

- Press the F1 Key to access the *Auto* Menu. The display shows:

```

AUTO SCAN MENU
All      i2c_IO
F1   F2   F3
    
```

- Press the F3 Key to access the *i2c_IO* Menu. The display shows:

```

RE-SCAN i2c BUS?
Yes      No
F1   F2   F3
    
```

- Press the F1 Key to select Yes. The MVS scans the entire network and brings on-line the new MVS-Modbus PCB(s). The display returns to:

```

RE-SCAN MENU
Auto      Man
F1   F2   F3
    
```

- Press the Esc Key to scroll up the menu tree or press the Auto/Man Key to return to channel monitoring.
- Follow the procedures in *Adding and Deleting MVS-Modbus Channels* and *Setting Up MVS-Modbus PCB to Interface with Modbus-Compatible Device* to complete setting up the system.

Adding and Deleting MVS-Modbus Channels

The *Add* Function adds (assigns) MVS-Modbus channels (up to two per MVS channel) to an MVS channel (vessel monitoring or math channel). Note that an MVS-Modbus channel **must be added** for the Modbus-compatible device to communicate with the corresponding MVS channel. It is not necessary to assign the MVS-Modbus channels sequentially to the MVS channels.

The *Del* Function allows previously added MVS-Modbus channels to be removed.

Note

For older versions of this product, the *Del* and *Add* Menus appear only if you entered the K-M Mfg Code (9111).

See Figure 3-1. Follow this procedure to add or delete MVS-Modbus channels:

- If in Auto Mode (Auto LED illuminated), press the Auto/Man Key to put the MVS in Manual Mode. The Auto LED turns off.
- Use the Arrow Keys to scroll the display to the MVS channel for which you want to add or delete the MVS-Modbus channel(s).
- Press the Menu Key to display the *Main* Menu. The display shows:

```

MAIN MENU
Disp  I/O  Cal →
F1   F2   F3
    
```

- Press the F2 Key to access the *I/O* Menu. The display shows:

```

INPUT/OUTPUT MENU
SetPt  Iout SerI →
F1   F2   F3
    
```

- Press the Menu Key to display the menu's second page. The display shows:

```

INPUT/OUTPUT MENU
RTare  Prnt PLC→
F1   F2   F3
    
```

- Press the F3 Key to access the *PLC* Menu. The display shows:

```

MODBUS MENU
Set    Reset Rprt→
F1   F2   F3
    
```

7. Press the Menu Key to access the menu's second page. The display shows:

```

MODBUS MENUS
Del  Add  →
F1   F2   F3

```

To add MVS-Modbus channels, proceed to Step 8. To delete MVS-Modbus channels, proceed to Step 12.

8. Press the F2 Key to add a channel. The display shows the channel number of the first available MVS-Modbus channel:

```

ADD MODBUS CHANN
Addr XX  Chan# YY
F1   F2   F3

```

The address and channel number of the first available MVS-Modbus channel displays instead of 'XX' and 'YY.'

9. Press the Arrow Keys to cycle through the available MVS-Modbus channels until the one you want is displayed. Press the Enter Key to add the channel. The display acknowledges the selection and returns to:

```

MODBUS MENUS
Del  Add  →
F1   F2   F3

```

10. Repeat Steps 8 and 9 to add an additional MVS-Modbus channel to this MVS channel if desired (up to two MVS-Modbus channels per MVS channel).
11. Press the Esc Key to scroll up the menu tree or the Auto/Man Key to return to channel monitoring.

Note

To assign additional MVS-Modbus channels to other MVS channels, return to channel monitoring, scroll to a different MVS channel using the Arrow Keys, and repeat Steps 3 through 11.

12. The remaining steps in this procedure deal with deleting an MVS-Modbus channel. Press the F1 Key to delete an MVS-Modbus channel. If there are two MVS-Modbus channels assigned to this MVS channel, the display looks like this:

```

1ST MODBUS CHAN
Addr XX Chan #YY
F1   F2   F3

```

The address and channel number of the first available MVS-Modbus channel displays instead of 'XX' and 'YY.'

13. If there are two MVS-Modbus channels assigned to this MVS channel, press the Arrow Keys to switch between the assigned MVS-Modbus channels until the one you want is displayed. Press the Enter Key to delete the channel. The display shows:

```

DELETE CHANNEL?
Yes           No
F1   F2   F3

```

14. Press the F1 Key to delete the channel. The display acknowledges the selection and returns to:

```

MODBUS MENUS
Del  Add  →
F1   F2   F3

```

15. Follow Steps 12 through 14 to delete another MVS-Modbus channel, press the Esc Key to scroll up the menu tree, or press the Auto/Man Key to return to channel monitoring.

Setting Up MVS-Modbus PCB to Interface with Modbus-Compatible Device

The following MVS-Modbus PCB setup parameters are entered in the *Set* Menu (see Figure 3-1): data type (*Typ*), mode (*Mode*), serial parameters (*Serl*), and starting index (*Str_Indx*). The setup parameters are selected while in the menu tree for **any MVS channel that has an MVS-Modbus channel assigned to it**, and apply to *all* the MVS-Modbus channels in the system. Table 3-1 shows the default setup parameters.

The starting index entered in the *Set* Menu can range from 0 to 9,998. To provide full 32-channel capacity, the entered starting index must be less than or equal to 9,967. **Note that the entered starting index range of 0 to 9,998 corresponds to an actual starting index range of 40,001 to 49,999 in the Modbus holding register.**

Parameter	Default Value
Typ	Data 1
Mode	Control
Serl:	
Addr	01 D, 01 H
Baud	19.2K
Stop	One
Par	None
Str_Indx:	
In_Reg	128
Out_Reg	0

Table 3-1. Setup Default Parameters

See Figure 3-1. Follow this procedure to set up the MVS-Modbus PCB:

1. If in Auto Mode (Auto LED illuminated), press the Auto/Man Key to put the MVS in Manual Mode. The Auto LED turns off.
2. Use the Arrow Keys to scroll the display to an MVS channel which has an MVS-Modbus channel(s) assigned to it.
3. Press the Menu Key to display the *Main* Menu. The display shows:

```

MAINMENU
Disp  I/O  Cal →
F1    F2    F3
    
```

4. Press the F2 Key to access the *I/O* Menu. The display shows:

```

INPUT/OUTPUT MENU
SetPt  Iout  Serl →
F1    F2    F3
    
```

5. Press the Menu Key to display the menu's second page. The display shows:

```

INPUT/OUTPUT MENU
RTare  Prnt  PLC →
F1    F2    F3
    
```

6. Press the F3 Key to access the *PLC* Menu. The display shows:

```

MODBUS MENU
Set    Reset  Rprt →
F1    F2    F3
    
```

7. Press the F1 Key to access the *Set* Menu. The display shows:

```

CHOOSE PARAMETER
Typ    Mode  Serl →
F1    F2    F3
    
```

8. Press the F2 Key to select the *Mode*. The display shows:

```

CHOOSE MODE:
Mon    *Ctrl
F1    F2    F3
    
```

(Asterisk indicates the current selection.)

9. Press the F1 Key to select Monitor Mode or the F3 Key to select Control Mode. The display acknowledges the selection and returns to:

```

CHOOSE PARAMETER
Typ    Mode  Serl →
F1    F2    F3
    
```

If you selected Control Mode (*Ctrl*), proceed to Step 12.

10. Press the F1 Key to select the data type. The display shows:

```

CHOOSE DATA TYPE
Data1*  Data2
F1    F2    F3
    
```

(Asterisk indicates the current selection.)

Note

Data type applies to Monitor Mode only. The MVS ignores your selection of data type if you select Control Mode (*Ctrl*). Data types 1 and 2 correspond to MVS-Modbus Control Mode commands 1 and 2, respectively. With the STX, for example, the gross weight is transmitted if data type 1 is selected or the net weight is transmitted if data type 2 is selected. Refer to Chapters 5 through 12 for the Control Mode commands for each K-M signal processor.

11. Press the F1 Key to select *Data1* or the F3 Key to select *Data2*. The display acknowledges the selection and returns to:

```

CHOOSE PARAMETER
Typ    Mode  Serl →
F1    F2    F3
    
```

12. Press the F3 Key to select *Serl*. The display shows:

```

SELECT FUNCTION
Addr    Baud →
F1    F2    F3
    
```

13. Press the F1 Key to set the address. The display shows:

```

MODBUS ADDRESS?
> XX Dec = YY Hex
F1    F2    F3
    
```

An existing address displays in place of 'XX' and 'YY.'

14. Use the Arrow Keys to scroll to a desired address or enter a decimal number with the keypad. The hexadecimal number automatically changes to correspond. Press the Enter Key to save the address in memory. The display acknowledges the selection and returns to:

```

SELECT FUNCTION
Addr          Baud→
F1    F2    F3

```

15. Press the F3 Key to select the baud rate. The display shows:

```

CHOOSE DATA RATE
4800  9600  19.2k*→
F1    F2    F3

```

(Asterisk indicates the current selection.)

16. If the displayed menu does not have the desired baud rate, press the Menu Key to display the menu's second page. The display shows:

```

CHOOSE DATA RATE
300   1200  2400→
F1    F2    F3

```

17. Press the F1, F2, or F3 Key to select the desired baud rate. The display acknowledges the selection and returns to:

```

SELECT FUNCTION
Addr          Baud→
F1    F2    F3

```

18. Press the Menu Key to display the menu's second page. The display shows:

```

SELECT FUNCTION
Stop        Par→
F1    F2    F3

```

19. Press the F1 Key to select the stop bits. The display shows:

```

SELECT STOP BITS
One*        Two
F1    F2    F3

```

(Asterisk indicates the current selection.)

20. Press the F1 Key for *One* or the F3 Key for *Two*. The display acknowledges the selection and returns to:

```

SELECT FUNCTION
Stop        Par→
F1    F2    F3

```

21. Press the F3 Key to select the parity. The display shows:

```

SELECT PARITY
None*  Even  Odd
F1    F2    F3

```

(Asterisk indicates the current selection.)

22. Press the F1, F2, or F3 Key to select the parity. The display acknowledges the selection and returns to:

```

SELECT FUNCTION
Stop        Par→
F1    F2    F3

```

23. Press the Esc Key to scroll up one screen. The display shows:

```

CHOOSE PARAMETER
Typ  Mode  Serl→
F1    F2    F3

```

24. Press the Menu Key to display the menu's second page. The display shows:

```

CHOOSE PARAMETER
Str_Indx  →
F1    F2    F3

```

25. Press the F1 Key to select the starting index. The display shows:

```

CHOOSE INDEX
In_Reg  Out_Reg
F1    F2    F3

```

26. Press the F1 Key to enter the starting index of the input register block. The display shows:

```

IN BLOCK START
>      XXX
F1    F2    F3

```

27. Use the Arrow Keys to scroll to a desired address or enter a number directly with the keypad. Press the Enter Key to enter the starting index in memory. The display acknowledges the selection and returns to:

```

CHOOSE INDEX
In_Reg  Out_Reg
F1    F2    F3

```

28. Press the F3 Key to enter the starting index of the output register block. The display shows:

```

OUT BLOCK START
>      XXX
F1    F2    F3

```

- Use the Arrow Keys to scroll to a desired address or enter a number directly with the keypad. Press the Enter Key to enter the starting index in memory. The display acknowledges the selection and returns to:

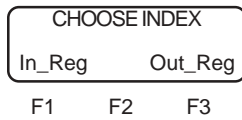

- Press the Esc Key to scroll up the menu tree or press the Auto/Man Key to return to channel monitoring.

Note

Reconfigure the Modbus-compatible device to match the MVS parameters you entered.

Resetting MVS-Modbus PCB to Default Parameters

The MVS-Modbus PCB default setup parameters are listed in Table 3-1. *Reset* resets the parameters to default values.

Note

Reset does not delete assigned channels. The *Service/Micro/RsRAM* Menu deletes assigned channels, but also **changes all system values (calibration data, setpoints, current outputs, etc.) to default values.**

See Figure 3-1. Follow this procedure to reset the MVS-Modbus PCB to default parameters.

- If in Auto Mode (Auto LED illuminated), press the Auto/Man Key to put the MVS in Manual Mode. The Auto LED turns off.
- Press the Menu Key to display the *Main* Menu. The display shows:

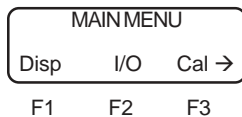

- Press the F2 Key to access the *I/O* Menu. The display shows:

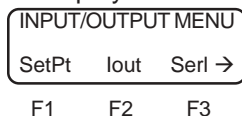

- Press the Menu Key to display the menu's second page. The display shows:

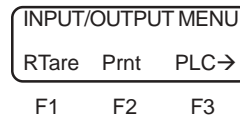

- Press the F3 Key to access the *PLC* Menu. The display shows:

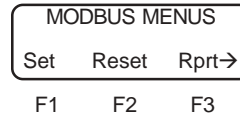

- Press the F2 Key to access the *Reset* Menu. The display prompts you to enter the Service Code (if you have not already entered it while in the Manual Mode in the menu tree). Then, the display shows:

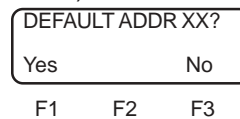

- Press the F1 Key to select *Yes*. The parameters are automatically defaulted. The display flashes a message acknowledging the selection. If there are no more Modbus PCBs to reset, the display then flashes *No Modbus Cards to Reset* and returns to:

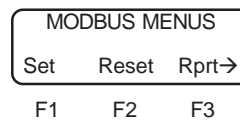

- Press the Esc Key to scroll up the menu tree or press the Auto/Man Key to return to channel monitoring.

Note

Reconfigure the Modbus-compatible device to match the MVS parameters you defaulted to.

Channel Report

The MVS allows you to view the MVS-Modbus channel numbers of the channels assigned to the current MVS channel. Follow this procedure:

- If in Auto Mode (Auto LED illuminated), press the Auto/Man Key to put the MVS in Manual Mode. The Auto LED turns off.
- Use the Arrow Keys to scroll the display to the MVS channel for which you want to view the channel report.

3. Press the Menu Key to display the *Main* Menu. The display shows:

```

MAINMENU
Disp  I/O  Cal →
F1    F2    F3

```

4. Press the F2 Key to access the *I/O* Menu. The display shows:

```

INPUT/OUTPUT MENU
SetPt  Iout  SerI →
F1    F2    F3

```

5. Press the Menu Key to display the menu's second page. The display shows:

```

INPUT/OUTPUT MENU
RTare  Prnt  PLC →
F1    F2    F3

```

6. Press the F3 Key to access the *PLC* Menu. The display shows:

```

MODBUS MENUS
Set  Reset  Rprt →
F1    F2    F3

```

7. Press the F3 Key to access the *Rprt* Menu. The display shows:

```

1ST MODBUS CHAN
Addr XX  Chan# YY
F1    F2    F3

```

In place of 'XX' and 'YY' are the address and channel number for the first assigned MVS-Modbus channel for the current MVS channel.

8. Press the Arrow Keys to view the second MVS-Modbus channel (if assigned).
 9. Press the Esc Key to return the display to:

```

MODBUS MENUS
Set  Reset  Rprt →
F1    F2    F3

```

10. Press the Esc Key to scroll up the menu tree or press the Auto/Man Key to return to channel monitoring.
 11. Repeat Steps 1 through 10 as required to view the MVS-Modbus channel numbers assigned to other MVS channels.

Chapter 4. Programming

Introduction

This chapter documents the format for K-M's program commands for interfacing with a Modbus-compatible device. This material is written for users who have experience with Modbus programming and have Modbus documentation available for reference. Refer to the appropriate K-M manual(s) for your K-M product(s). These manuals provide complete installation, operation, and calibration procedures, and product specifications.

The MVS-Modbus PCB provides an interface for MVS weight, level, and flow systems to a Modbus-compatible device. This chapter documents the format for the Control Mode commands and contains the miscellaneous system commands for the MVS. The actual commands for each K-M signal processor supported by the MVS are in the following:

- MVS-Modbus/MVS ADC, Setpoints, and Current Outputs — Chapter 5
- MVS-Modbus/Sonologic 5000 Series-ITU-SSU — Chapter 6
- MVS-Modbus/ITX Belt Scale Integrator — Chapter 7
- MVS-Modbus/STX Signal Transmitter — Chapter 8
- MVS-Modbus/Models 1000 and 1020 — Chapter 9
- MVS-Modbus/Sonologic II & ultra-wave™ — Chapter 10
- MVS-Modbus/Weigh II — Chapter 11
- MVS-Modbus/SVS 2000 — Chapter 12

Modes of Operation

The MVS-Modbus operates in one of two modes:

- Control Mode — The MVS-Modbus can read monitoring data or read or write data on a number of operational parameters, including calibration values, setpoints, current outputs, etc.
- Monitor Mode — The MVS-Modbus can only read one parameter of monitoring data, such as gross weight, net weight, level, or flow. This parameter corresponds to the parameter defined by Command 1 or Command 2 for Control Mode commands. Selection of Command 1 (*Data 1*) or Command 2 (*Data 2*) data is described in Chapter 3, Setting Up the MVS-Modbus.

Data Structure

The MVS-Modbus PCB has a capacity of 32 channels. Up to two MVS-Modbus channels can be assigned to each MVS channel (vessel monitoring or math channel).

In Control Mode, the Modbus-compatible device transfers data to and from the MVS-Modbus PCB using Input and Output instructions. The data obtained from the MVS-Modbus PCB is set up by instructions sent by Input commands. Figure 4-1 shows the Input bit/word configuration for Control Mode. The first word of each channel is the data word. Data is placed here if the command is to send data from the Modbus-compatible device to the MVS. The second word of each channel is the command word, which may include subcommands and additional data (if the data could not fit within the 16 bits of the first word). Bit 15 of the command word is called the Write Bit. Bit 15 is set to '1' when the command is to send data from the Modbus-compatible device to the MVS. Bit 15 is set to '0' when the command is to send data from the MVS to the Modbus-compatible device. After the Input instruction has been completed, an Output instruction is used.

Figure 4-2 shows the Output bit/word configuration for Control Mode. The first word of each channel is the data word. Data is placed here if the command in the Input table is to send data from the MVS to the Modbus-compatible device. The second word of each channel is the command word. The command used in the Input is echoed here to confirm the command has been processed. Bit 15 of the command word is the error bit. If bit 15 is set to '1,' use the Status Command ('7') to determine the error source. If the error condition is cleared, Bit 15 is reset to '0.'

Figure 4-3 shows the Monitor Mode output bit/word configuration. There is only one word for each channel, the data word. Bit 15 of the word is the polarity bit. Bit 15 is set to '1' when the value is negative.

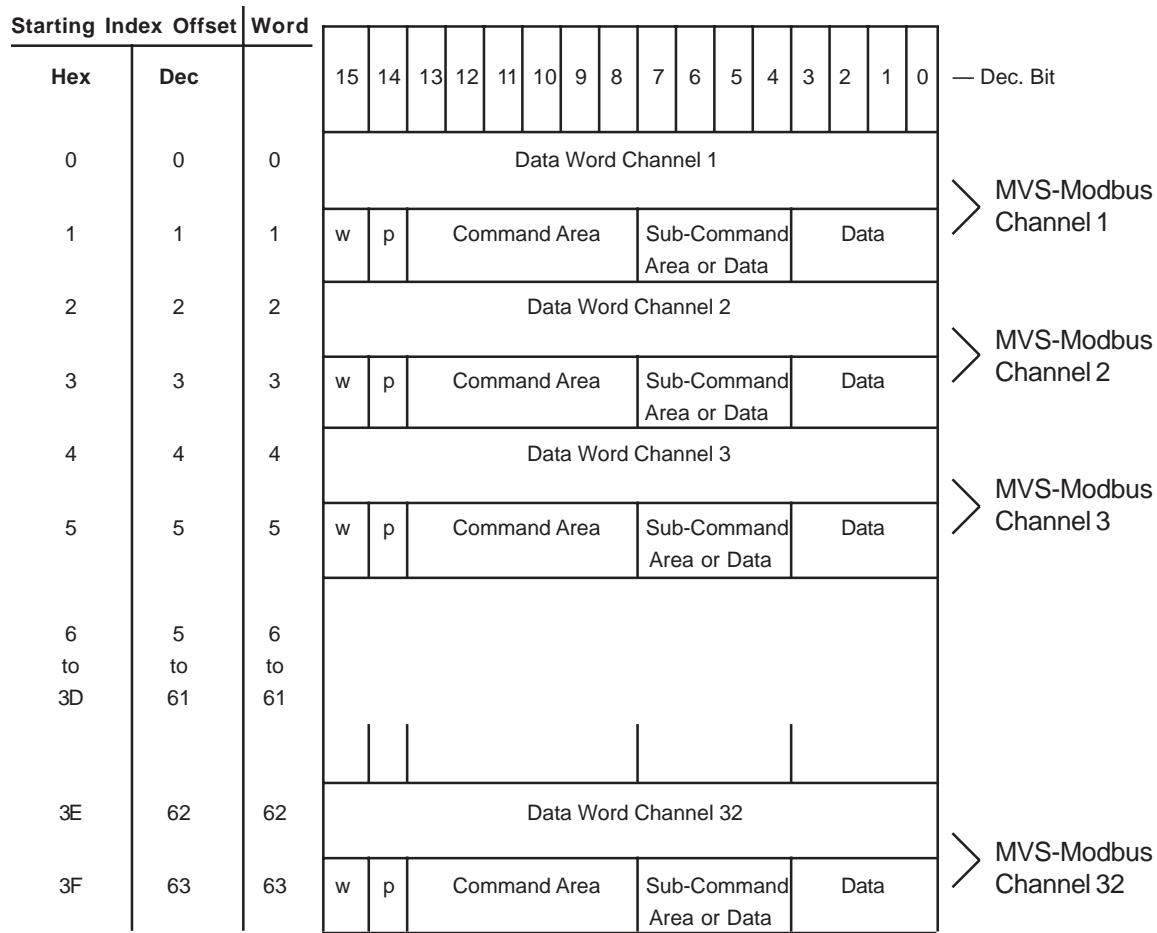

Control Mode Input Register Table

Notes:

1. Two words are used per MVS-Modbus channel. The first word is the Data Word and the second word is the Command Word.
2. Description of the Data Word: Bits 0-15 is the data area, used when data is to be sent/received.
3. Description of the Command Word:
 - Bits 0-7 is the data area. This area is used when data larger than 16 bit is to be sent/received (STX, ITX, Weigh II, and SVS 2000). Data Bits 0-15 are in the Data Word in the first word for the channel and the remaining data are in this area of the Command Word.
 - Bits 4-7 is the Sub-Command Area. This area is used (when not being used for data) to point to specific setpoints, current outputs, or entries in the linearization table for the MVS channel.
 - Bits 8-13 is the Command Area.
 - Bit 14 is the Polarity bit (p): '0' = +; '1' = -
 - Bit 15 is the Write bit (w). Set this bit to '1' when sending data from the Modbus-compatible device to the MVS. Set this bit to '0' when requesting that data be sent from the MVS to the Modbus-compatible device.

Figure 4-1. Basic Bit/Byte Word Configuration for Control Mode Input Register

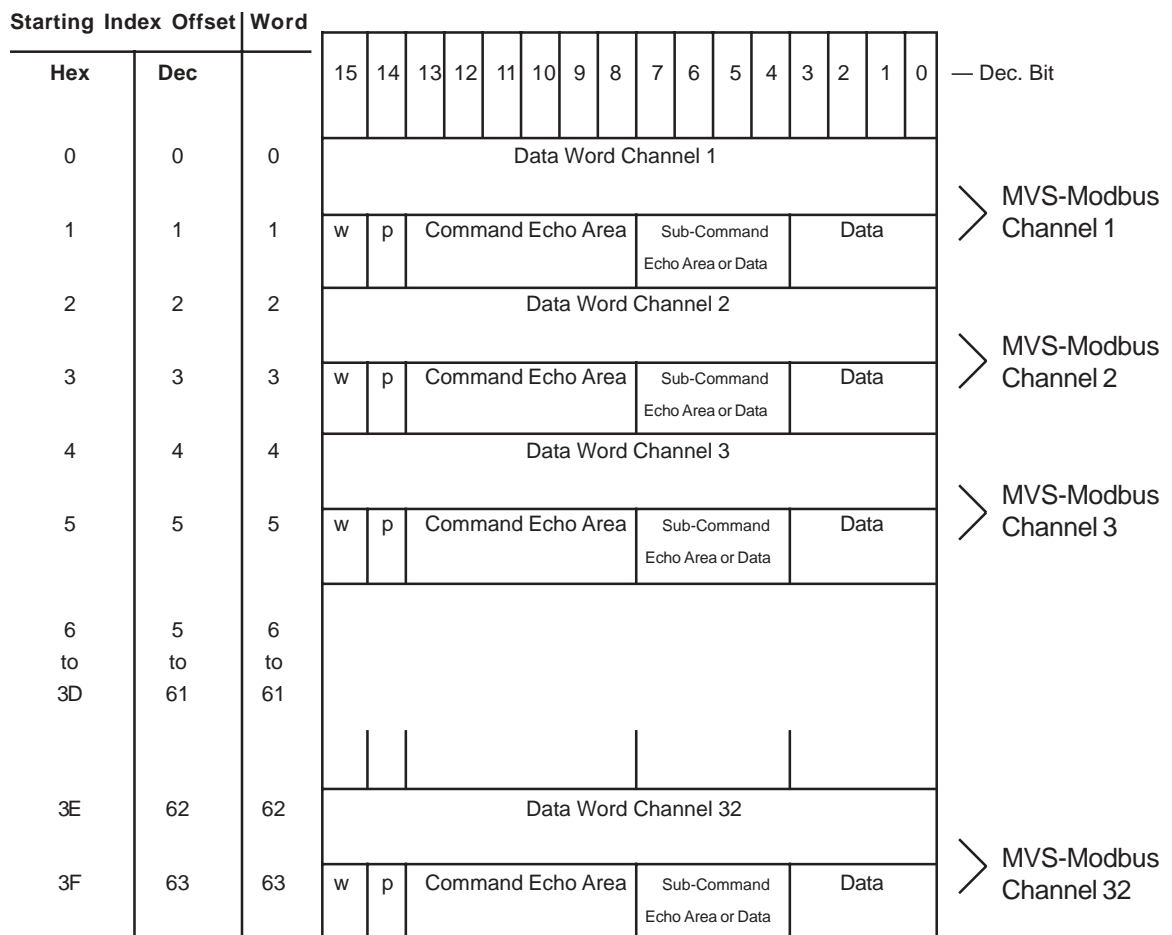

Control Mode Output Table

Notes:

- Two words are used per MVS-Modbus channel. The first word is the Data Word and the second word is the Command Word.
- Description of the Data Word: Bits 0-15 is the data area, used when data is to be sent/received.
- Description of the Command Word:
 - Bits 0-7 is the data area. This area is used when data larger than 16 bit is to be sent/received (STX, ITX, Weigh II, and SVS 2000). Data Bits 0-15 are in the Data Word in the first word for the channel and the remaining data are in this area of the Command Word.
 - Bits 4-7 is the Sub-Command Echo Area. This area is used (when not being used for data) to point to specific setpoints, current outputs, or entries in the linearization table for the MVS channel.
 - Bits 8-13 is the Command Echo Area.
 - Bit 14 is the Polarity bit (p): '0' = +; '1' = -
 - Bit 15 is the Error bit (e).

Figure 4-2. Basic Bit/Byte Word Configuration for Control Mode Output Table

Dec. Bit -	15	14	13	12	11	10	9	8	7	6	5	4	3	2	1	0
Word 0 -	p	Data Word Channel 1														Modbus Channel 1
Word 1 -	p	Data Word Channel 2														Modbus Channel 2
Word 2 -	p	Data Word Channel 3														Modbus Channel 3
Word 3 through Word 30 -																
Word 31 -	p	Data Word Channel 32														Modbus Channel 32

Monitor Mode Table

Notes:

1. Description of the Data Word:
 - Bits 0-14 is the data area
 - Bit 15 is the Polarity bit (p): '0' = +; '1' = -
2. The following values are returned for error conditions:
 - FFFF (hexadecimal) = ADC overrange (counts overrange)
 - 7FFF (hexadecimal) = scale overrange
(engineering units magnitude > maximum allowed for signal processor)
 - 8000 (hexadecimal) = scale underrange
(engineering units magnitude > maximum allowed for signal processor and polarity bit = 1)

Figure 4-3. Basic Bit/Byte Word Configuration for Monitor Mode Table

Control Mode Command Format Notes

Three types of commands are used when interfacing between the Modbus-compatible device and the MVS:

1. **Read only** commands are used to read a calculated parameter, such as a gross weight or net weight. This type of command is **always** used to send data from the **MVS to the Modbus-compatible device**. The Input and Output tables for these commands reflect that the data can only go from the MVS to the Modbus-compatible device. These commands are identified as “read only” in the Control Mode Commands.
2. **Set only** commands are used to set a parameter, such as a command to tare a channel. This type of command is **always** used to send data from the **Modbus-compatible device to the MVS**. The Input and Output tables for these commands reflect that the data can only go from the Modbus-compatible device to the MVS. These commands are identified as “set only” in the Control Mode Commands.
3. **Read or Set** commands are used to read a parameter value **or** set a parameter value, such as a command for Lo Span Calibration. This type of command can be used to send data from the MVS to the Modbus-compatible device or from the Modbus-compatible device to the MVS. Note that the Input and Output tables for these commands in the Control Mode Commands are written for the case where the data is being sent from the MVS to the Modbus-compatible device. However, these commands can also be used to set parameters.

Control Mode Miscellaneous System Commands

Quick Command Reference Table for MVS-Modbus Miscellaneous System Commands

System Parameters	Command Dec	Hex	Range	Comments	Page No.
Null Command	0	0	—	Returns zero in all data/command fields	4-6
MVS Device & Revision Report	5	5	0-255 MSB 0-255 LSB	MSB MVS-Modbus firmware revision: 0-127=XNEW-XZZV, 128-255=NEW-ZZV. LSB Signal processor type: 0=MVS, 1=Sono 5000 series-ITU-SSU, 2=STX; 5=ITX, 10=1000, 11=1020, 7=Sono II / u-w, 8 = Weigh II, 14 = SVS 2000	4-6

Control Mode Commands: MVS-Modbus Miscellaneous System Commands

Null Command (read only)

Dec: 0 Hex: 0 Range: N/A

Input Table

Dec. Bit -	15	14	13	12	11	10	9	8	7	6	5	4	3	2	1	0
Word 0 -	0	0	0	0	0	0	0	0	0	0	0	0	0	0	0	0
Word 1 -	0	0	0	0	0	0	0	0	0	0	0	0	0	0	0	0

Data Word
Command Word

Output Table

Dec. Bit -	15	14	13	12	11	10	9	8	7	6	5	4	3	2	1	0
Word 0 -	0	0	0	0	0	0	0	0	0	0	0	0	0	0	0	0
Word 1 -	e	p	0	0	0	0	0	0	0	0	0	0	0	0	0	0

Data Word
Command Word

MVS Device and Revision Report (read only)

Dec: 5 Hex: 5 Range: 0-255 MSB; 0-255 LSB

Input Table

Dec. Bit -	15	14	13	12	11	10	9	8	7	6	5	4	3	2	1	0
Word 0 -	0	0	0	0	0	0	0	0	0	0	0	0	0	0	0	0
Word 1 -	0	0	0	0	0	1	0	1	0	0	0	0	0	0	0	0

Data Word
Command Word

Output Table

Dec. Bit -	15	14	13	12	11	10	9	8	7	6	5	4	3	2	1	0
Word 0 -	d	d	d	d	d	d	d	d	d	d	d	d	d	d	d	d
Word 1 -	e	p	0	0	0	1	0	1	0	0	0	0	0	0	0	0

Data Word
Command Word

Notes: MSB MVS-Modbus firmware revision: 0-127=XNEW-XZZV, 128-255=NEW-ZZV.
LSB Signal processor type: 0=MVS, 1=Sono 5000 series-ITU-SSU, 2=STX, 5=ITX, 10=1000, 11=1020, 7=Sono II, 8 = Weigh II, 14 = SVS 2000

Legend: Dec = # in decimal form; Hex = # in hexadecimal form; e = error; p = polarity; ddd... = data; D... = subcommand

Chapter 5. Commands for MVS-Modbus/MVS ADC, Setpoints, and Current Outputs

Chapter Contents

Control Mode Commands: MVS ADC Card	5-2
Control Mode Commands: MVS Setpoints	5-9
Control Mode Commands: MVS Current Output	5-13

Note

Refer to Chapter 4 for general information on programming.

Quick Command Reference Table for MVS-Modbus/MVS ADC Card

MVS ADC Parameters	Command		Range	Comments	Page No.
	Dec	Hex			
Gross Weight	1	1	0-65535	Value in selected engineering units	5-3
Net Weight	2	2	0-±65535	Value in selected engineering units	5-3
Tare	6	6	—		5-3
Status (includes errors)	7	7	0-255		5-4
Zero Cal (Auto)	8	8	0-65535	Value in selected engineering units	5-4
Lo Span Cal (Auto)	9	9	0-65535	Value in selected engineering units	5-4
Hi Span Cal (Auto)	10	A	0-65535	Value in selected engineering units	5-5
Scale Factor Cts (Manual)	11	B	0-65535		5-5
Scale Factor Wt (Manual)	12	C	0-65535	Value in selected engineering units	5-5
Zero Counts (Manual)	13	D	0-65535		5-6
Excitation	14	E	0-255		5-6
Averaging Factor	16	10	1-255		5-6
Raw Input Counts	30	1E	0-65535	For linearization table. Bits 5, 6, & 7 of Command Word is Linear Table entry number: 0=1st, 1=2nd, 2=3rd, 3=4th, 4=5th	5-7
Corrected Output Counts	31	1F	0-65535	For linearization table. Bits 5, 6, & 7 of Command Word is Linear Table entry number: 0=1st, 1=2nd, 2=3rd, 3=4th, 4=5th	5-7
Linearization Enable	32	20	0-1	0=linearization off, 1=linearization on	5-7
Raw A/D Counts	33	21	0-65535		5-8

Legend: Dec = numbers in decimal form; Hex = numbers in hexadecimal form

Control Mode Commands: MVS-Modbus/MVS ADC Card

Gross Weight (read only)

Dec: 1 Hex: 1 Range: 0-65535

Input Table

Dec. Bit -	15	14	13	12	11	10	9	8	7	6	5	4	3	2	1	0
Word 0 -	0	0	0	0	0	0	0	0	0	0	0	0	0	0	0	0
Word 1 -	0	0	0	0	0	0	0	1	0	0	0	0	0	0	0	0

Data Word
Command Word

Output Table

Dec. Bit -	15	14	13	12	11	10	9	8	7	6	5	4	3	2	1	0
Word 0 -	d	d	d	d	d	d	d	d	d	d	d	d	d	d	d	d
Word 1 -	e	p	0	0	0	0	0	1	0	0	0	0	0	0	0	0

Data Word
Command Word

Net Weight (read only)

Dec: 2 Hex: 2 Range: 0-±65535

Input Table

Dec. Bit -	15	14	13	12	11	10	9	8	7	6	5	4	3	2	1	0
Word 0 -	0	0	0	0	0	0	0	0	0	0	0	0	0	0	0	0
Word 1 -	0	0	0	0	0	0	1	0	0	0	0	0	0	0	0	0

Data Word
Command Word

Output Table

Dec. Bit -	15	14	13	12	11	10	9	8	7	6	5	4	3	2	1	0
Word 0 -	d	d	d	d	d	d	d	d	d	d	d	d	d	d	d	d
Word 1 -	e	p	0	0	0	0	1	0	0	0	0	0	0	0	0	0

Data Word
Command Word

Tare (set only)

Dec: 6 Hex: 6 Range: N/A

Input Table

Dec. Bit -	15	14	13	12	11	10	9	8	7	6	5	4	3	2	1	0
Word 0 -	0	0	0	0	0	0	0	0	0	0	0	0	0	0	0	1
Word 1 -	1	0	0	0	0	1	1	0	0	0	0	0	0	0	0	0

Data Word
Command Word

Output Table

Dec. Bit -	15	14	13	12	11	10	9	8	7	6	5	4	3	2	1	0
Word 0 -	0	0	0	0	0	0	0	0	0	0	0	0	0	0	0	0
Word 1 -	e	p	0	0	0	1	1	0	0	0	0	0	0	0	0	0

Data Word
Command Word

Note: To set tare, set bit 0 of Data Word to 1 and use the Write bit.

Legend: Dec = # in decimal form; Hex = # in hexadecimal form; e = error; p = polarity; ddd... = data; D... = subcommand

Control Mode Commands: MVS-Modbus/MVS ADC Card

Status (read only)

Dec: 7 Hex: 7 Range: 0-255

Input Table

Dec. Bit -	15	14	13	12	11	10	9	8	7	6	5	4	3	2	1	0	
Word 0 -	0	0	0	0	0	0	0	0	0	0	0	0	0	0	0	0	Data Word
Word 1 -	0	0	0	0	0	1	1	1	0	0	0	0	0	0	0	0	Command Word

Output Table

Dec. Bit -	15	14	13	12	11	10	9	8	7	6	5	4	3	2	1	0	
Word 0 -	d	d	d	d	d	d	d	d	0	0	0	0	0	0	0	0	Data Word
Word 1 -	e	p	0	0	0	1	1	1	0	0	0	0	0	0	0	0	Command Word

Note: Description of status (bits 8-15 of data word)

Bit 8 - Net units negative

Bit 9 - N/A

Bit 10 - During Auto Cal "Warning: Move More Material"

Bit 11 - During Auto Cal: "Ambiguous Error",

lo_cnt>hi_cnt. Other: Illegal average factor

Bit 12 - COM error condition

Bit 13 - Analog input overrange

Bit 14 - Engineering unit overflow

Bit 15 - Gross units negative

Zero Cal (Auto Calibration)

Dec: 8 Hex: 8 Range: 0-65535

Input Table

Dec. Bit -	15	14	13	12	11	10	9	8	7	6	5	4	3	2	1	0	
Word 0 -	0	0	0	0	0	0	0	0	0	0	0	0	0	0	0	0	Data Word
Word 1 -	0	0	0	0	1	0	0	0	0	0	0	0	0	0	0	0	Command Word

Output Table

Dec. Bit -	15	14	13	12	11	10	9	8	7	6	5	4	3	2	1	0	
Word 0 -	d	d	d	d	d	d	d	d	d	d	d	d	d	d	d	d	Data Word
Word 1 -	e	p	0	0	1	0	0	0	0	0	0	0	0	0	0	0	Command Word

Note: You must move material when performing Auto Cal. See *MVS Installation and Operation Manual*.

Lo Span Cal (Auto Calibration)

Dec: 9 Hex: 9 Range: 0-65535

Input Table

Dec. Bit -	15	14	13	12	11	10	9	8	7	6	5	4	3	2	1	0	
Word 0 -	0	0	0	0	0	0	0	0	0	0	0	0	0	0	0	0	Data Word
Word 1 -	0	0	0	0	1	0	0	1	0	0	0	0	0	0	0	0	Command Word

Output Table

Dec. Bit -	15	14	13	12	11	10	9	8	7	6	5	4	3	2	1	0	
Word 0 -	d	d	d	d	d	d	d	d	d	d	d	d	d	d	d	d	Data Word
Word 1 -	e	p	0	0	1	0	0	1	0	0	0	0	0	0	0	0	Command Word

Note: You must move material when performing Auto Cal. See *MVS Installation and Operation Manual*.

Legend: Dec = # in decimal form; Hex = # in hexadecimal form; e = error; p = polarity; ddd... = data; D... = subcommand

Control Mode Commands: MVS-Modbus/MVS ADC Card

Hi Span Cal (Auto Calibration)

Dec: 10 Hex: A Range: 0-65535

Input Table

Dec. Bit -	15	14	13	12	11	10	9	8	7	6	5	4	3	2	1	0
Word 0 -	0	0	0	0	0	0	0	0	0	0	0	0	0	0	0	0
Word 1 -	0	0	0	0	1	0	1	0	0	0	0	0	0	0	0	0

Data Word
Command Word

Output Table

Dec. Bit -	15	14	13	12	11	10	9	8	7	6	5	4	3	2	1	0
Word 0 -	d	d	d	d	d	d	d	d	d	d	d	d	d	d	d	d
Word 1 -	e	p	0	0	1	0	1	0	0	0	0	0	0	0	0	0

Data Word
Command Word

Note: You must move material when performing Auto Cal. See *MVS Installation and Operation Manual*.

Scale Factor Counts (Manual Calibration)

Dec: 11 Hex: B Range: 0-65535

Input Table

Dec. Bit -	15	14	13	12	11	10	9	8	7	6	5	4	3	2	1	0
Word 0 -	0	0	0	0	0	0	0	0	0	0	0	0	0	0	0	0
Word 1 -	0	0	0	0	1	0	1	1	0	0	0	0	0	0	0	0

Data Word
Command Word

Output Table

Dec. Bit -	15	14	13	12	11	10	9	8	7	6	5	4	3	2	1	0
Word 0 -	d	d	d	d	d	d	d	d	d	d	d	d	d	d	d	d
Word 1 -	e	p	0	0	1	0	1	1	0	0	0	0	0	0	0	0

Data Word
Command Word

Scale Factor Weight (Manual Calibration)

Dec: 12 Hex: C Range: 0-65535

Input Table

Dec. Bit -	15	14	13	12	11	10	9	8	7	6	5	4	3	2	1	0
Word 0 -	0	0	0	0	0	0	0	0	0	0	0	0	0	0	0	0
Word 1 -	0	0	0	0	1	1	0	0	0	0	0	0	0	0	0	0

Data Word
Command Word

Output Table

Dec. Bit -	15	14	13	12	11	10	9	8	7	6	5	4	3	2	1	0
Word 0 -	d	d	d	d	d	d	d	d	d	d	d	d	d	d	d	d
Word 1 -	e	p	0	0	1	1	0	0	0	0	0	0	0	0	0	0

Data Word
Command Word

Legend: Dec = # in decimal form; Hex = # in hexadecimal form; e = error; p = polarity; ddd... = data; D... = subcommand

Control Mode Commands: MVS-Modbus/MVS ADC Card

Zero Counts (Manual Calibration)

Dec: 13 Hex: D Range: 0-65535

Input Table

Dec. Bit -	15	14	13	12	11	10	9	8	7	6	5	4	3	2	1	0
Word 0 -	0	0	0	0	0	0	0	0	0	0	0	0	0	0	0	0
Word 1 -	0	0	0	0	1	1	0	1	0	0	0	0	0	0	0	0

Data Word
Command Word

Output Table

Dec. Bit -	15	14	13	12	11	10	9	8	7	6	5	4	3	2	1	0
Word 0 -	d	d	d	d	d	d	d	d	d	d	d	d	d	d	d	d
Word 1 -	e	p	0	0	1	1	0	1	0	0	0	0	0	0	0	0

Data Word
Command Word

Excitation

Dec: 14 Hex: E Range: 0-255

Input Table

Dec. Bit -	15	14	13	12	11	10	9	8	7	6	5	4	3	2	1	0
Word 0 -	0	0	0	0	0	0	0	0	0	0	0	0	0	0	0	0
Word 1 -	0	0	0	0	1	1	1	0	0	0	0	0	0	0	0	0

Data Word
Command Word

Output Table

Dec. Bit -	15	14	13	12	11	10	9	8	7	6	5	4	3	2	1	0
Word 0 -	0	0	0	0	0	0	0	0	d	d	d	d	d	d	d	d
Word 1 -	e	p	0	0	1	1	1	0	0	0	0	0	0	0	0	0

Data Word
Command Word

Averaging Factor

Dec: 16 Hex: 10 Range: 1-255

Input Table

Dec. Bit -	15	14	13	12	11	10	9	8	7	6	5	4	3	2	1	0
Word 0 -	0	0	0	0	0	0	0	0	0	0	0	0	0	0	0	0
Word 1 -	0	0	0	1	0	0	0	0	0	0	0	0	0	0	0	0

Data Word
Command Word

Output Table

Dec. Bit -	15	14	13	12	11	10	9	8	7	6	5	4	3	2	1	0
Word 0 -	0	0	0	0	0	0	0	0	d	d	d	d	d	d	d	d
Word 1 -	e	p	0	1	0	0	0	0	0	0	0	0	0	0	0	0

Data Word
Command Word

Legend: Dec = # in decimal form; Hex = # in hexadecimal form; e = error; p = polarity; ddd... = data; D... = subcommand

Control Mode Commands: MVS-Modbus/MVS ADC Card

Raw Input Counts (Linearization Table)

Dec: 30 Hex: 1E Range: 0-65535

Input Table

Dec. Bit -	15	14	13	12	11	10	9	8	7	6	5	4	3	2	1	0	
Word 0 -	0	0	0	0	0	0	0	0	0	0	0	0	0	0	0	0	Data Word
Word 1 -	0	0	0	1	1	1	1	0	D	D	D	0	0	0	0	0	Command Word

Output Table

Dec. Bit -	15	14	13	12	11	10	9	8	7	6	5	4	3	2	1	0	
Word 0 -	d	d	d	d	d	d	d	d	d	d	d	d	d	d	d	d	Data Word
Word 1 -	e	p	0	1	1	1	1	0	0	0	0	0	0	0	0	0	Command Word

Note: Bits 5, 6, and 7 are the Linear Table entry number (0=1st, 1=2nd, 2=3rd, 3=4th, and 4=5th)

Corrected Output Counts (Linearization Table)

Dec: 31 Hex: 1F Range: 0-65535

Input Table

Dec. Bit -	15	14	13	12	11	10	9	8	7	6	5	4	3	2	1	0	
Word 0 -	0	0	0	0	0	0	0	0	0	0	0	0	0	0	0	0	Data Word
Word 1 -	0	0	0	1	1	1	1	1	D	D	D	0	0	0	0	0	Command Word

Output Table

Dec. Bit -	15	14	13	12	11	10	9	8	7	6	5	4	3	2	1	0	
Word 0 -	d	d	d	d	d	d	d	d	d	d	d	d	d	d	d	d	Data Word
Word 1 -	e	p	0	1	1	1	1	1	0	0	0	0	0	0	0	0	Command Word

Note: Bits 5, 6, and 7 are the Linear Table entry number (0=1st, 1=2nd, 2=3rd, 3=4th, and 4=5th)

Linearization Enable

Dec: 32 Hex: 20 Range: 0-1

Input Table

Dec. Bit -	15	14	13	12	11	10	9	8	7	6	5	4	3	2	1	0	
Word 0 -	0	0	0	0	0	0	0	0	0	0	0	0	0	0	0	0	Data Word
Word 1 -	0	0	1	0	0	0	0	0	0	0	0	0	0	0	0	0	Command Word

Output Table

Dec. Bit -	15	14	13	12	11	10	9	8	7	6	5	4	3	2	1	0	
Word 0 -	0	0	0	0	0	0	0	0	0	0	0	0	0	0	0	d	Data Word
Word 1 -	e	p	1	0	0	0	0	0	0	0	0	0	0	0	0	0	Command Word

Note: Bit 0 of data word: 0=disable, 1=enable

Legend: Dec = # in decimal form; Hex = # in hexadecimal form; e = error; p = polarity; ddd... = data; D... = subcommand

Control Mode Commands: MVS-Modbus/MVS ADC Card

Raw A/D Counts (read only)

Dec: 33 Hex: 21 Range: 0-65535

Input Table

Dec. Bit -	15	14	13	12	11	10	9	8	7	6	5	4	3	2	1	0	
Word 0 -	0	0	0	0	0	0	0	0	0	0	0	0	0	0	0	0	Data Word
Word 1 -	0	0	1	0	0	0	0	1	0	0	0	0	0	0	0	0	Command Word

Output Table

Dec. Bit -	15	14	13	12	11	10	9	8	7	6	5	4	3	2	1	0	
Word 0 -	d	d	d	d	d	d	d	d	d	d	d	d	d	d	d	d	Data Word
Word 1 -	e	p	1	0	0	0	0	1	0	0	0	0	0	0	0	0	Command Word

Legend: Dec = # in decimal form; Hex = # in hexadecimal form; e = error; p = polarity; ddd... = data; D... = subcommand

Quick Command Reference Table for MVS Setpoints

Setpoint Parameters	Command		Range	Comments	Page No.
	Dec	Hex			
Setpoint Value ^{1,2}	40	28	0-±65535	Value in selected engineering units	5-10
Deadband ¹	41	29	0-65535	Value in selected engineering units	5-10
Hi/Lo ¹	42	2A	0-1	0=Lo, 1=Hi	5-11
Net/Gross ¹	43	2B	0-1	0=Gross, 1=Net	5-11
Failsafe ¹	44	2C	0-2	0=Off, 1=No Change, 2=On	5-12
Force Mode ^{1,3}	45	2D	—		5-12

Notes:

- Bits 4, 5, and 6 of Command Word is the setpoint number (000=Setpoint 1 through 111=Setpoint 8).
- When Net Mode is selected, Bit 7 of Command Word is polarity for the Setpoint Value.
- To activate the Force Mode, set bit 1 of Data Word to 1 and set the Write bit to 1. To deactivate the Force Mode, set bit 1 of the Data Word to 0 and set the write bit to 1. Bit 0 of Data Word represents the state of the setpoint (1=On, 0=Off) when the Force Mode is active. When the Force Mode is inactive, the setpoint is controlled by the MVS microprocessor card.

CAUTION

The Force Mode command removes control of the setpoint from the MVS and gives it to the PLC. The MVS will not update the setpoint when this mode is active.

Control Mode Commands: MVS-Modbus/MVS Setpoints

Setpoint Value

Dec: 40 Hex: 28 Range: 0-±65535

Input Table

Dec. Bit -	15	14	13	12	11	10	9	8	7	6	5	4	3	2	1	0	
Word 0 -	0	0	0	0	0	0	0	0	0	0	0	0	0	0	0	0	Data Word
Word 1 -	0	0	1	0	1	0	0	0	0	D	D	D	0	0	0	0	Command Word

Output Table

Dec. Bit -	15	14	13	12	11	10	9	8	7	6	5	4	3	2	1	0	
Word 0 -	d	d	d	d	d	d	d	d	d	d	d	d	d	d	d	d	Data Word
Word 1 -	e	0	1	0	1	0	0	0	p	0	0	0	0	0	0	0	Command Word

Notes:

1. Bits 4, 5, and 6 of Command Word is the setpoint number (000=Setpoint 1 through 111=Setpoint 8).
2. When Net Mode is selected, Bit 7 of Command Word is polarity for the Setpoint Value.

Deadband

Dec: 41 Hex: 29 Range: 0-65535

Input Table

Dec. Bit -	15	14	13	12	11	10	9	8	7	6	5	4	3	2	1	0	
Word 0 -	0	0	0	0	0	0	0	0	0	0	0	0	0	0	0	0	Data Word
Word 1 -	0	0	1	0	1	0	0	1	0	D	D	D	0	0	0	0	Command Word

Output Table

Dec. Bit -	15	14	13	12	11	10	9	8	7	6	5	4	3	2	1	0	
Word 0 -	d	d	d	d	d	d	d	d	d	d	d	d	d	d	d	d	Data Word
Word 1 -	e	p	1	0	1	0	0	1	0	0	0	0	0	0	0	0	Command Word

Note: Bits 4, 5, and 6 of Command Word is the setpoint number (000=Setpoint 1 through 111=Setpoint 8)

Control Mode Commands: MVS-Modbus/MVS Setpoints

Hi/Lo

Dec: 42 Hex: 2A Range: 0-1

Input Table

Dec. Bit -	15	14	13	12	11	10	9	8	7	6	5	4	3	2	1	0	
Word 0 -	0	0	0	0	0	0	0	0	0	0	0	0	0	0	0	0	Data Word
Word 1 -	0	0	1	0	1	0	1	0	0	D	D	D	0	0	0	0	Command Word

Output Table

Dec. Bit -	15	14	13	12	11	10	9	8	7	6	5	4	3	2	1	0	
Word 0 -	0	0	0	0	0	0	0	0	0	0	0	0	0	0	0	d	Data Word
Word 1 -	e	p	1	0	1	0	1	0	0	0	0	0	0	0	0	0	Command Word

Notes:

- Bits 4, 5, and 6 of Command Word is the setpoint number (000=Setpoint 1 through 111=Setpoint 8)
- Bit 0 of Data Word: 0=Lo, 1=Hi

Net/Gross

Dec: 43 Hex: 2B Range: 0-1

Input Table

Dec. Bit -	15	14	13	12	11	10	9	8	7	6	5	4	3	2	1	0	
Word 0 -	0	0	0	0	0	0	0	0	0	0	0	0	0	0	0	0	Data Word
Word 1 -	0	0	1	0	1	0	1	1	0	D	D	D	0	0	0	0	Command Word

Output Table

Dec. Bit -	15	14	13	12	11	10	9	8	7	6	5	4	3	2	1	0	
Word 0 -	0	0	0	0	0	0	0	0	0	0	0	0	0	0	0	d	Data Word
Word 1 -	e	p	1	0	1	0	1	1	0	0	0	0	0	0	0	0	Command Word

Notes:

- Bits 4, 5, and 6 of Command Word is the setpoint number (000=Setpoint 1 through 111=Setpoint 8)
- Bit 0 of Data Word: 0=Gross, 1=Net

Control Mode Commands: MVS-Modbus/MVS Setpoints

Failsafe

Dec: 44 Hex: 2C Range: 0-2

Input Table

Dec. Bit -	15	14	13	12	11	10	9	8	7	6	5	4	3	2	1	0	
Word 0 -	0	0	0	0	0	0	0	0	0	0	0	0	0	0	0	0	Data Word
Word 1 -	0	0	1	0	1	1	0	0	0	D	D	D	0	0	0	0	Command Word

Output Table

Dec. Bit -	15	14	13	12	11	10	9	8	7	6	5	4	3	2	1	0	
Word 0 -	0	0	0	0	0	0	0	0	0	0	0	0	0	0	d	d	Data Word
Word 1 -	e	p	1	0	1	1	0	0	0	0	0	0	0	0	0	0	Command Word

Notes:

1. Bits 4, 5, and 6 of Command Word is the setpoint number (000=Setpoint 1 through 111=Setpoint 8)
2. Bits 0 and 1 of Data Word: 0=Off, 1=No Change, 2=On

Force Mode (set only)

Dec: 45 Hex: 2D Range: N/A

Input Table

Dec. Bit -	15	14	13	12	11	10	9	8	7	6	5	4	3	2	1	0	
Word 0 -	0	0	0	0	0	0	0	0	0	0	0	0	0	0	1	d	Data Word
Word 1 -	1	0	1	0	1	1	0	1	0	D	D	D	0	0	0	0	Command Word

Output Table

Dec. Bit -	15	14	13	12	11	10	9	8	7	6	5	4	3	2	1	0	
Word 0 -	0	0	0	0	0	0	0	0	0	0	0	0	0	0	0	0	Data Word
Word 1 -	0	0	1	0	1	1	0	1	0	0	0	0	0	0	0	0	Command Word

Notes:

1. Bits 4, 5, and 6 of Command Word is the setpoint number (000=Setpoint 1 through 111=Setpoint 8).
2. To activate the Force Mode, set bit 1 of the Data Word to 1 and set the write bit (bit 15 of Command Word) to 1. To deactivate the Force Mode, set bit 1 of the Data Word to 0 and set the write bit to 1.
3. Bit 0 of the Data Word represents the state of the setpoint (1=On, 0=Off) when the Force Mode is active. When the Force Mode is inactive, the setpoint is controlled by the MVS microprocessor card.

CAUTION

The Force Mode command removes control of the setpoint from the MVS and gives it to the PLC. The MVS will not update the setpoint when this mode is active.

Quick Command Reference Table for MVS Current Output

Current Output Parameters	Command		Range	Comments	Page No.
	Dec	Hex			
0/4 mA Mode ¹	46	2E	0-1	0=0-20mA; 1=4-20mA	5-14
Lo mA Value ^{1,2}	47	2F	0-±65535	Value in selected engineering units	5-14
20 mA Value ^{1,2}	48	30	0-±65535	Value in selected engineering units	5-15
Net/Gross ¹	49	31	0-1	0=Gross; 1=Net	5-15
Failsafe ¹	50	32	0-2	0=Lo; 1=Hi; 2=No Change	5-16
Force Mode ^{1,3}	51	33	0-16383		5-16

Notes:

1. Bit 4 of Command Word is the current output channel number (0=1st channel and 1=2nd channel).
2. When Net Mode is selected, Bit 7 of Command Word is polarity for the Lo mA and 20 mA values.
3. To activate the Force Mode, set bit 0 of Command Word to 1 and use the Write bit. The data in bits 0-13 of the Data Word is the value loaded into the Current Transmitter PCB of the MVS. When the Force Mode is inactive (Bit 0 of Command Word set to 0), the current output is controlled by the MVS microprocessor card.

CAUTION

The Force Mode command removes control of the current output from the MVS and gives it to the PLC. The MVS will not update the current output when this mode is active.

Control Mode Commands: MVS-Modbus/MVS Current Output

0/4 mA Mode

Dec: 46 Hex: 2E Range: 0-1

Input Table

Dec. Bit -	15	14	13	12	11	10	9	8	7	6	5	4	3	2	1	0
Word 0 -	0	0	0	0	0	0	0	0	0	0	0	0	0	0	0	0
Word 1 -	0	0	1	0	1	1	1	0	0	0	0	D	0	0	0	0

Data Word
Command Word

Output Table

Dec. Bit -	15	14	13	12	11	10	9	8	7	6	5	4	3	2	1	0
Word 0 -	0	0	0	0	0	0	0	0	0	0	0	0	0	0	0	d
Word 1 -	e	p	1	0	1	1	1	0	0	0	0	0	0	0	0	0

Data Word
Command Word

Notes:

1. Bit 4 of Command Word is the current output channel number (0=1st channel and 1=2nd channel)
2. Bit 0 of Data Word: 0=0-20 mA, 1=4-20 mA

Lo mA Value

Dec: 47 Hex: 2F Range: 0-±65535

Input Table

Dec. Bit -	15	14	13	12	11	10	9	8	7	6	5	4	3	2	1	0
Word 0 -	0	0	0	0	0	0	0	0	0	0	0	0	0	0	0	0
Word 1 -	0	0	1	0	1	1	1	1	0	0	0	D	0	0	0	0

Data Word
Command Word

Output Table

Dec. Bit -	15	14	13	12	11	10	9	8	7	6	5	4	3	2	1	0
Word 0 -	d	d	d	d	d	d	d	d	d	d	d	d	d	d	d	d
Word 1 -	e	0	1	0	1	1	1	1	p	0	0	0	0	0	0	0

Data Word
Command Word

Notes:

1. Bit 4 of Command Word is the current output channel number (0=1st channel and 1=2nd channel)
2. When Net Mode is selected, Bit 7 of Command Word is polarity of Lo mA value.

Control Mode Commands: MVS-Modbus/MVS Current Output

20 mA Value

Dec: 48 Hex: 30 Range: 0-±65535

Input Table

Dec. Bit -	15	14	13	12	11	10	9	8	7	6	5	4	3	2	1	0	
Word 0 -	0	0	0	0	0	0	0	0	0	0	0	0	0	0	0	0	Data Word
Word 1 -	0	0	1	1	0	0	0	0	0	0	0	D	0	0	0	0	Command Word

Output Table

Dec. Bit -	15	14	13	12	11	10	9	8	7	6	5	4	3	2	1	0	
Word 0 -	d	d	d	d	d	d	d	d	d	d	d	d	d	d	d	d	Data Word
Word 1 -	e	0	1	1	0	0	0	0	p	0	0	0	0	0	0	0	Command Word

Notes:

1. Bit 4 of Command Word is the current output channel number (0=1st channel and 1=2nd channel).
2. When Net Mode is selected, Bit 7 of Command Word is polarity of 20 mA value.

Net/Gross

Dec: 49 Hex: 31 Range: 0-1

Input Table

Dec. Bit -	15	14	13	12	11	10	9	8	7	6	5	4	3	2	1	0	
Word 0 -	0	0	0	0	0	0	0	0	0	0	0	0	0	0	0	0	Data Word
Word 1 -	0	0	1	1	0	0	0	1	0	0	0	D	0	0	0	0	Command Word

Output Table

Dec. Bit -	15	14	13	12	11	10	9	8	7	6	5	4	3	2	1	0	
Word 0 -	0	0	0	0	0	0	0	0	0	0	0	0	0	0	0	d	Data Word
Word 1 -	e	p	1	1	0	0	0	1	0	0	0	0	0	0	0	0	Command Word

Notes:

1. Bit 4 of Command Word is the current output channel number (0=1st channel and 1=2nd channel).
2. Bit 0 of Data Word: 0=Gross, 1=Net

Control Mode Commands: MVS-Modbus/MVS Current Output

Failsafe

Dec: 50 Hex: 32 Range: 0-2

Input Table

Dec. Bit -	15	14	13	12	11	10	9	8	7	6	5	4	3	2	1	0	
Word 0 -	0	0	0	0	0	0	0	0	0	0	0	0	0	0	0	0	Data Word
Word 1 -	0	0	1	1	0	0	1	0	0	0	0	D	0	0	0	0	Command Word

Output Table

Dec. Bit -	15	14	13	12	11	10	9	8	7	6	5	4	3	2	1	0	
Word 0 -	0	0	0	0	0	0	0	0	0	0	0	0	0	0	d	d	Data Word
Word 1 -	e	p	1	1	0	0	1	0	0	0	0	0	0	0	0	0	Command Word

Notes:

1. Bit 4 of Command Word is the current output channel number (0=1st channel and 1=2nd channel).
2. Bits 0 and 1 of Data Word: 0=Lo, 1=Hi, 2=No Change

Force Mode (set only)

Dec: 51 Hex: 33 Range: 0-16383

Input Table

Dec. Bit -	15	14	13	12	11	10	9	8	7	6	5	4	3	2	1	0	
Word 0 -	0	0	d	d	d	d	d	d	d	d	d	d	d	d	d	d	Data Word
Word 1 -	1	0	1	1	0	0	1	1	0	0	0	D	0	0	0	1	Command Word

Output Table

Dec. Bit -	15	14	13	12	11	10	9	8	7	6	5	4	3	2	1	0	
Word 0 -	0	0	0	0	0	0	0	0	0	0	0	0	0	0	0	0	Data Word
Word 1 -	0	0	1	1	0	0	1	1	0	0	0	0	0	0	0	0	Command Word

Notes:

1. Bit 4 of Command Word is the current output channel number (0=1st channel and 1=2nd channel).
2. To activate the Force Mode, set bit 0 of the Command Word to 1 and set the write bit (bit 15) to 1. To deactivate the Force Mode, set bit 0 of the Command Word to 0 and set the write bit to 1.
3. The data in bits 0-13 of the Data Word is the value loaded into the Current Transmitter PCB of the MVS. 0 is associated with 0/4 mA (dependent on what was selected for 0/4 mA Mode) and 16383 is associated with 20 mA. The MVS-Modbus does a linear interpolation between those two currents to calculate the value of the forced current.
4. When the Force Mode is inactive (bit 0 of Command Word set to 0), the current output is controlled by the MVS microprocessor card.

CAUTION

The Force Mode command removes control of the current output from the MVS and gives it to the PLC. The MVS will not update the current output when this mode is active.

Chapter 6. Commands for MVS-Modbus/ Sonologic 5000 Series-ITU-SSU

Quick Command Reference Table for MVS-Modbus with Sonologic 5000 Series-ITU-SSU

Sonologic Parameters	Command Dec	Hex	Range	Comments	Page No.
Level	1	1	0-9999	Value in selected engineering units	6-2
Status (includes errors)	7	7	0-255		6-2

Note

Refer to Chapter 4 for general information on programming.

Control Mode Commands: MVS-Modbus/Sonologic 5000 Series-ITU-SSU

Level (read only)

Dec: 1 Hex: 1 Range: 0-9999

Input Table

Dec. Bit -	15	14	13	12	11	10	9	8	7	6	5	4	3	2	1	0	
Word 0 -	0	0	0	0	0	0	0	0	0	0	0	0	0	0	0	0	Data Word
Word 1 -	0	0	0	0	0	0	0	1	0	0	0	0	0	0	0	0	Command Word

Output Table

Dec. Bit -	15	14	13	12	11	10	9	8	7	6	5	4	3	2	1	0	
Word 0 -	0	0	d	d	d	d	d	d	d	d	d	d	d	d	d	d	Data Word
Word 1 -	e	p	0	0	0	0	0	1	0	0	0	0	0	0	0	0	Command Word

Status (read only)

Dec: 7 Hex: 7 Range: 0-255

Input Table

Dec. Bit -	15	14	13	12	11	10	9	8	7	6	5	4	3	2	1	0	
Word 0 -	0	0	0	0	0	0	0	0	0	0	0	0	0	0	0	0	Data Word
Word 1 -	0	0	0	0	0	1	1	1	0	0	0	0	0	0	0	0	Command Word

Output Table

Dec. Bit -	15	14	13	12	11	10	9	8	7	6	5	4	3	2	1	0	
Word 0 -	d	d	d	d	d	d	d	d	0	0	0	0	0	0	0	0	Data Word
Word 1 -	e	p	0	0	0	1	1	1	0	0	0	0	0	0	0	0	Command Word

Notes: Description of status (bits 8-15 of data word)

Bit 8 -Net units negative	Bit 12 - COM error condition
Bit 9 - Echo Loss	Bit 13 - N/A
Bit 10 -N/A	Bit 14 - N/A
Bit 11 - Illegal average factor	Bit 15 - Gross units negative

Chapter 7. Commands for MVS-Modbus/ ITX Belt Scale Integrator

Quick Command Reference Table for MVS-Modbus/ ITX Belt Scale Integrator

ITX Parameters	Command		Range	Comments	Page No.
	Dec	Hex			
Flow Rate	1	1	0-65535	Value in selected engineering units	7-2
Belt Speed	2	2	0-65535	Value in selected engineering units	7-2
Totalizer Low Word	3	3	0-65535	Value in selected engineering units	7-2
Totalizer High Word	4	4	0-65535	Value in selected engineering units	7-3
Status (includes errors)	7	7	0-255		7-3
Excitation	14	E	0-255		7-4
0/4 mA Mode ¹	17	11	0-1	1=4/20 mode, 0=0/20 mode	7-4
Lo mA Value ¹	18	12	0-65535	Value in selected engineering units	7-4
Hi mA Value ¹	19	13	0-65535	Value in selected engineering units	7-5
Belt Speed/Flow Rate Mode for Current Output ¹	20	14	0-1	1=current output tracks belt speed, 0=current output tracks flow rate	7-5
Failsafe for Current Output ¹	21	15	0-2	0=Lo, 1=Hi, 2=No Change	7-5
0 mA Factory Cal (local)	22	16	0-16383		7-6
4 mA Factory Cal (local)	23	17	0-16383		7-6
20 mA Factory Cal (local)	24	18	0-16383		7-6

Notes:

1. Command is for main current output channel only.

Note

Refer to Chapter 4 for general information on programming.

Control Mode Commands: MVS-Modbus/ITX

Flow Rate (read only)

Dec: 1 Hex: 1 Range: 0-65535

Input Table

Dec. Bit -	15	14	13	12	11	10	9	8	7	6	5	4	3	2	1	0
Word 0 -	0	0	0	0	0	0	0	0	0	0	0	0	0	0	0	0
Word 1 -	0	0	0	0	0	0	0	1	0	0	0	0	0	0	0	0

Data Word
Command Word

Output Table

Dec. Bit -	15	14	13	12	11	10	9	8	7	6	5	4	3	2	1	0
Word 0 -	d	d	d	d	d	d	d	d	d	d	d	d	d	d	d	d
Word 1 -	e	p	0	0	0	0	0	1	0	0	0	0	0	0	0	0

Data Word
Command Word

Belt Speed (read only)

Dec: 2 Hex: 2 Range: 0-65535

Input Table

Dec. Bit -	15	14	13	12	11	10	9	8	7	6	5	4	3	2	1	0
Word 0 -	0	0	0	0	0	0	0	0	0	0	0	0	0	0	0	0
Word 1 -	0	0	0	0	0	0	1	0	0	0	0	0	0	0	0	0

Data Word
Command Word

Output Table

Dec. Bit -	15	14	13	12	11	10	9	8	7	6	5	4	3	2	1	0
Word 0 -	d	d	d	d	d	d	d	d	d	d	d	d	d	d	d	d
Word 1 -	e	p	0	0	0	0	1	0	0	0	0	0	0	0	0	0

Data Word
Command Word

Totalizer Low Word (read only)

Dec: 3 Hex: 3 Range: 0-65535

Input Table

Dec. Bit -	15	14	13	12	11	10	9	8	7	6	5	4	3	2	1	0
Word 0 -	0	0	0	0	0	0	0	0	0	0	0	0	0	0	0	0
Word 1 -	0	0	0	0	0	0	1	1	0	0	0	0	0	0	0	0

Data Word
Command Word

Output Table

Dec. Bit -	15	14	13	12	11	10	9	8	7	6	5	4	3	2	1	0
Word 0 -	d	d	d	d	d	d	d	d	d	d	d	d	d	d	d	d
Word 1 -	e	p	0	0	0	0	1	1	0	0	0	0	0	0	0	0

Data Word
Command Word

Legend: Dec = # in decimal form; Hex = # in hexadecimal form; e = error; p = polarity; ddd... = data; D... = subcommand

Control Mode Commands: MVS-Modbus/ITX

Totalizer High Word (read only)

Dec: 4 Hex: 4 Range: 0-65535

Input Table

Dec. Bit -	15	14	13	12	11	10	9	8	7	6	5	4	3	2	1	0
Word 0 -	0	0	0	0	0	0	0	0	0	0	0	0	0	0	0	0
Word 1 -	0	0	0	0	0	1	0	0	0	0	0	0	0	0	0	0

Data Word
Command Word

Output Table

Dec. Bit -	15	14	13	12	11	10	9	8	7	6	5	4	3	2	1	0
Word 0 -	d	d	d	d	d	d	d	d	d	d	d	d	d	d	d	d
Word 1 -	e	p	0	0	0	1	0	0	0	0	0	0	0	0	0	0

Data Word
Command Word

Status (read only)

Dec: 7 Hex: 7 Range: 0-255

Input Table

Dec. Bit -	15	14	13	12	11	10	9	8	7	6	5	4	3	2	1	0
Word 0 -	0	0	0	0	0	0	0	0	0	0	0	0	0	0	0	0
Word 1 -	0	0	0	0	0	1	1	1	0	0	0	0	0	0	0	0

Data Word
Command Word

Output Table

Dec. Bit -	15	14	13	12	11	10	9	8	7	6	5	4	3	2	1	0
Word 0 -	d	d	d	d	d	d	d	d	0	0	0	0	0	0	0	0
Word 1 -	e	p	0	0	0	1	1	1	0	0	0	0	0	0	0	0

Data Word
Command Word

Notes: Description of status (bits 8-15 of data word)

- | | |
|---|--|
| Bit 8 -Auto zero in progress | Bit 13 - Analog input overranging A/D converter |
| Bit 9 - Output pulse divided by 10 active | Bit 14 - Engineering unit overflow error, flow rate units overflow error |
| Bit 10 -Output pulse rate over running buffer | Bit 15 - Flow rate negative |
| Bit 11 - 24 hours since a zero occurred | |
| Bit 12 - COM error condition | |

Control Mode Commands: MVS-Modbus/ITX

Excitation

Dec: 14 Hex: E Range: 0-255

Input Table

Dec. Bit -	15	14	13	12	11	10	9	8	7	6	5	4	3	2	1	0
Word 0 -	0	0	0	0	0	0	0	0	0	0	0	0	0	0	0	0
Word 1 -	0	0	0	0	1	1	1	0	0	0	0	0	0	0	0	0

Data Word
Command Word

Output Table

Dec. Bit -	15	14	13	12	11	10	9	8	7	6	5	4	3	2	1	0
Word 0 -	0	0	0	0	0	0	0	0	d	d	d	d	d	d	d	d
Word 1 -	e	p	0	0	1	1	1	0	0	0	0	0	0	0	0	0

Data Word
Command Word

0/4 mA Mode (for main current output channel)

Dec: 17 Hex: 11 Range: 0-1

Input Table

Dec. Bit -	15	14	13	12	11	10	9	8	7	6	5	4	3	2	1	0
Word 0 -	0	0	0	0	0	0	0	0	0	0	0	0	0	0	0	0
Word 1 -	0	0	0	1	0	0	0	1	0	0	0	0	0	0	0	0

Data Word
Command Word

Output Table

Dec. Bit -	15	14	13	12	11	10	9	8	7	6	5	4	3	2	1	0
Word 0 -	0	0	0	0	0	0	0	0	0	0	0	0	0	0	0	d
Word 1 -	e	p	0	1	0	0	0	1	0	0	0	0	0	0	0	0

Data Word
Command Word

Note: Bit 0 of Data Word:1=4/20 mode, 0=0/20 mode

Lo mA Value (for main current output channel)

Dec: 18 Hex: 12 Range: 0-65535

Input Table

Dec. Bit -	15	14	13	12	11	10	9	8	7	6	5	4	3	2	1	0
Word 0 -	0	0	0	0	0	0	0	0	0	0	0	0	0	0	0	0
Word 1 -	0	0	0	1	0	0	1	0	0	0	0	0	0	0	0	0

Data Word
Command Word

Output Table

Dec. Bit -	15	14	13	12	11	10	9	8	7	6	5	4	3	2	1	0
Word 0 -	d	d	d	d	d	d	d	d	d	d	d	d	d	d	d	d
Word 1 -	e	p	0	1	0	0	1	0	0	0	0	0	0	0	0	0

Data Word
Command Word

Legend: Dec = # in decimal form; Hex = # in hexadecimal form; e = error; p = polarity; ddd... = data; D... = subcommand

Control Mode Commands: MVS-Modbus/ITX

Hi mA Value (for main current output channel)

Dec: 19 Hex: 13 Range: 0-65535

Input Table

Dec. Bit -	15	14	13	12	11	10	9	8	7	6	5	4	3	2	1	0
Word 0 -	0	0	0	0	0	0	0	0	0	0	0	0	0	0	0	0
Word 1 -	0	0	0	1	0	0	1	1	0	0	0	0	0	0	0	0

Data Word
Command Word

Output Table

Dec. Bit -	15	14	13	12	11	10	9	8	7	6	5	4	3	2	1	0
Word 0 -	d	d	d	d	d	d	d	d	d	d	d	d	d	d	d	d
Word 1 -	e	p	0	1	0	0	1	1	0	0	0	0	0	0	0	0

Data Word
Command Word

Belt Speed/Flow Rate Mode (for main current output channel)

Dec: 20 Hex: 14 Range: 0-1

Input Table

Dec. Bit -	15	14	13	12	11	10	9	8	7	6	5	4	3	2	1	0
Word 0 -	0	0	0	0	0	0	0	0	0	0	0	0	0	0	0	0
Word 1 -	0	0	0	1	0	1	0	0	0	0	0	0	0	0	0	0

Data Word
Command Word

Output Table

Dec. Bit -	15	14	13	12	11	10	9	8	7	6	5	4	3	2	1	0
Word 0 -	0	0	0	0	0	0	0	0	0	0	0	0	0	0	0	d
Word 1 -	e	p	0	1	0	1	0	0	0	0	0	0	0	0	0	0

Data Word
Command Word

Note: Bit 0 of Data Word: 1=Current output tracks belt speed, 0=current output tracks flow rate

Failsafe (for main current output channel)

Dec: 21 Hex: 15 Range: 0-2

Input Table

Dec. Bit -	15	14	13	12	11	10	9	8	7	6	5	4	3	2	1	0
Word 0 -	0	0	0	0	0	0	0	0	0	0	0	0	0	0	0	0
Word 1 -	0	0	0	1	0	1	0	1	0	0	0	0	0	0	0	0

Data Word
Command Word

Output Table

Dec. Bit -	15	14	13	12	11	10	9	8	7	6	5	4	3	2	1	0
Word 0 -	0	0	0	0	0	0	0	0	0	0	0	0	0	0	d	d
Word 1 -	e	p	0	1	0	1	0	1	0	0	0	0	0	0	0	0

Data Word
Command Word

Note: Bits 0 and 1 of Data Word: 0=Lo, 1=Hi, 2=No Change

Legend: Dec = # in decimal form; Hex = # in hexadecimal form; e = error; p = polarity; ddd... = data; D... = subcommand

Control Mode Commands: MVS-Modbus/ITX

0 mA Factory Cal (local)

Dec: 22 Hex: 16 Range: 0-16383

Input Table

Dec. Bit -	15	14	13	12	11	10	9	8	7	6	5	4	3	2	1	0
Word 0 -	0	0	0	0	0	0	0	0	0	0	0	0	0	0	0	0
Word 1 -	0	0	0	1	0	1	1	0	0	0	0	0	0	0	0	0

Data Word
Command Word

Output Table

Dec. Bit -	15	14	13	12	11	10	9	8	7	6	5	4	3	2	1	0
Word 0 -	0	0	d	d	d	d	d	d	d	d	d	d	d	d	d	d
Word 1 -	e	p	0	1	0	1	1	0	0	0	0	0	0	0	0	0

Data Word
Command Word

4 mA Factory Cal (local)

Dec: 23 Hex: 17 Range: 0-16383

Input Table

Dec. Bit -	15	14	13	12	11	10	9	8	7	6	5	4	3	2	1	0
Word 0 -	0	0	0	0	0	0	0	0	0	0	0	0	0	0	0	0
Word 1 -	0	0	0	1	0	1	1	1	0	0	0	0	0	0	0	0

Data Word
Command Word

Output Table

Dec. Bit -	15	14	13	12	11	10	9	8	7	6	5	4	3	2	1	0
Word 0 -	0	0	d	d	d	d	d	d	d	d	d	d	d	d	d	d
Word 1 -	e	p	0	1	0	1	1	1	0	0	0	0	0	0	0	0

Data Word
Command Word

20 mA Factory Cal (local)

Dec: 24 Hex: 18 Range: 0-16383

Input Table

Dec. Bit -	15	14	13	12	11	10	9	8	7	6	5	4	3	2	1	0
Word 0 -	0	0	0	0	0	0	0	0	0	0	0	0	0	0	0	0
Word 1 -	0	0	0	1	1	0	0	0	0	0	0	0	0	0	0	0

Data Word
Command Word

Output Table

Dec. Bit -	15	14	13	12	11	10	9	8	7	6	5	4	3	2	1	0
Word 0 -	0	0	d	d	d	d	d	d	d	d	d	d	d	d	d	d
Word 1 -	e	p	0	1	1	0	0	0	0	0	0	0	0	0	0	0

Data Word
Command Word

Legend: Dec = # in decimal form; Hex = # in hexadecimal form; e = error; p = polarity; ddd... = data; D... = subcommand

Chapter 8. Commands for MVS-Modbus/ STX Signal Transmitter

Quick Command Reference Table for MVS-Modbus/STX Signal Transmitter

STX Parameters	Command		Range	Comments	Page No.
	Dec	Hex			
Gross Weight	1	1	0-999999	Value in selected engineering units	8-2
Net Weight	2	2	0-±999999	Value in selected engineering units	8-2
Tare	6	6	—		8-2
Status (includes errors)	7	7	0-255		8-3
Zero Cal (Auto)	8	8	0-999999	Value in selected engineering units	8-3
Lo Span Cal (Auto)	9	9	0-999999	Value in selected engineering units	8-4
Hi Span Cal (Auto)	10	A	0-999999	Value in selected engineering units	8-4
Scale Factor Cts (Manual)	11	B	0-2097151		8-4
Scale Factor Wt (Manual)	12	C	0-999999	Value in selected engineering units	8-5
Zero Counts (Manual)	13	D	0-2097151		8-5
Excitation	14	E	0-255		8-5
Analog/Digital Mode	15	F	0-1	1=analog mode, 0=digital mode	8-6
Averaging Factor	16	10	1-255		8-6
0/4 Mode	17	11	0-1	1=4/20 mode, 0=0/20 mode	8-6
Lo mA Value ¹	18	12	0-±999999	Value in selected engineering units	8-7
Hi mA Value ¹	19	13	0-±999999	Value in selected engineering units	8-7
Net/Gross Mode for Current Output	20	14	0-1	1=Net, 0=Gross	8-7
Failsafe for Current Output	21	15	0-2	0=Lo, 1=Hi, 2=No Change	8-8
0 mA Factory Cal (local)	22	16	0-16383		8-8
4 mA Factory Cal (local)	23	17	0-16383		8-8
20 mA Factory Cal (local)	24	18	0-16383		8-9
Raw Input Counts	30	1E	0-2097151	For linearization table. Bits 5, 6, & 7 of Command Word is Linear Table Entry Number (0=1st, 1=2nd, 2=3rd, 3=4th, 4=5th)	8-9
Corrected Output Counts	31	1F	0-2097151	For linearization table. Bits 5, 6, & 7 of Command Word is Linear Table Entry Number (0=1st, 1=2nd, 2=3rd, 3=4th, 4=5th)	8-9
Linearization Enable	32	20	0-1	0=linearization off, 1=linearization on	8-10
Raw A/D Counts	33	21	0-2097151		8-10

Note:

1. When Net Mode is selected, Bit 4 of Command Word is polarity for the Lo mA and Hi mA values.

Note

Refer to Chapter 4 for general information on programming.

Legend: Dec = numbers in decimal form; Hex = numbers in hexadecimal form

Control Mode Commands: MVS-Modbus/STX

Gross Weight (read only)

Dec: 1 Hex: 1 Range: 0-999999

Input Table

Dec. Bit -	15	14	13	12	11	10	9	8	7	6	5	4	3	2	1	0
Word 0 -	0	0	0	0	0	0	0	0	0	0	0	0	0	0	0	0
Word 1 -	0	0	0	0	0	0	0	1	0	0	0	0	0	0	0	0

Data Word
Command Word

Output Table

Dec. Bit -	15	14	13	12	11	10	9	8	7	6	5	4	3	2	1	0
Word 0 -	d	d	d	d	d	d	d	d	d	d	d	d	d	d	d	d
Word 1 -	e	p	0	0	0	0	0	1	0	0	0	0	d	d	d	d

Data Word
Command Word

Net Weight (read only)

Dec: 2 Hex: 2 Range: 0-±999999

Input Table

Dec. Bit -	15	14	13	12	11	10	9	8	7	6	5	4	3	2	1	0
Word 0 -	0	0	0	0	0	0	0	0	0	0	0	0	0	0	0	0
Word 1 -	0	0	0	0	0	0	1	0	0	0	0	0	0	0	0	0

Data Word
Command Word

Output Table

Dec. Bit -	15	14	13	12	11	10	9	8	7	6	5	4	3	2	1	0
Word 0 -	d	d	d	d	d	d	d	d	d	d	d	d	d	d	d	d
Word 1 -	e	p	0	0	0	0	1	0	0	0	0	0	d	d	d	d

Data Word
Command Word

Tare (set only)

Dec: 6 Hex: 6 Range: N/A

Input Table

Dec. Bit -	15	14	13	12	11	10	9	8	7	6	5	4	3	2	1	0
Word 0 -	0	0	0	0	0	0	0	0	0	0	0	0	0	0	0	1
Word 1 -	1	0	0	0	0	1	1	0	0	0	0	0	0	0	0	0

Data Word
Command Word

Output Table

Dec. Bit -	15	14	13	12	11	10	9	8	7	6	5	4	3	2	1	0
Word 0 -	0	0	0	0	0	0	0	0	0	0	0	0	0	0	0	0
Word 1 -	e	p	0	0	0	1	1	0	0	0	0	0	0	0	0	0

Data Word
Command Word

Note: To set tare, set bit 0 of Data Word to 1 and use the Write bit.

Legend: Dec = # in decimal form; Hex = # in hexadecimal form; e = error; p = polarity; ddd... = data; D... = subcommand

Control Mode Commands: MVS-Modbus/STX

Status (read only)

Dec: 7 Hex: 7 Range: 0-255

Input Table

Dec. Bit -	15	14	13	12	11	10	9	8	7	6	5	4	3	2	1	0
Word 0 -	0	0	0	0	0	0	0	0	0	0	0	0	0	0	0	0
Word 1 -	0	0	0	0	0	1	1	1	0	0	0	0	0	0	0	0

Data Word
Command Word

Output Table

Dec. Bit -	15	14	13	12	11	10	9	8	7	6	5	4	3	2	1	0
Word 0 -	d	d	d	d	d	d	d	d	0	0	0	0	0	0	0	0
Word 1 -	e	p	0	0	0	1	1	1	0	0	0	0	0	0	0	0

Data Word
Command Word

Notes: Description of status (bits 8-15 of data word)

Bit 8 - Net units negative

Bit 9 - N/A

Bit 10 - During Auto Cal "Warning: Move More Material"

Bit 11 - During Auto Cal: "Ambiguous Error"

lo_cnt>hi_cnt. Other: Illegal average factor

Bit 12 - COM error condition

Bit 13 - Analog input overrange

Bit 14 - Engineering unit overflow

Bit 15 - Gross units negative

Zero Cal (Auto Calibration)

Dec: 8 Hex: 8 Range: 0-999999

Input Table

Dec. Bit -	15	14	13	12	11	10	9	8	7	6	5	4	3	2	1	0
Word 0 -	0	0	0	0	0	0	0	0	0	0	0	0	0	0	0	0
Word 1 -	0	0	0	0	1	0	0	0	0	0	0	0	0	0	0	0

Data Word
Command Word

Output Table

Dec. Bit -	15	14	13	12	11	10	9	8	7	6	5	4	3	2	1	0
Word 0 -	d	d	d	d	d	d	d	d	d	d	d	d	d	d	d	d
Word 1 -	e	p	0	0	1	0	0	0	0	0	0	0	d	d	d	d

Data Word
Command Word

Legend: Dec = # in decimal form; Hex = # in hexadecimal form; e = error; p = polarity; ddd... = data; D... = subcommand

Control Mode Commands: MVS-Modbus/STX

Lo Span Cal (Auto Calibration)

Dec: 9 Hex: 9 Range: 0-999999

Input Table

Dec. Bit -	15	14	13	12	11	10	9	8	7	6	5	4	3	2	1	0	
Word 0 -	0	0	0	0	0	0	0	0	0	0	0	0	0	0	0	0	Data Word
Word 1 -	0	0	0	0	1	0	0	1	0	0	0	0	0	0	0	0	Command Word

Output Table

Dec. Bit -	15	14	13	12	11	10	9	8	7	6	5	4	3	2	1	0	
Word 0 -	d	d	d	d	d	d	d	d	d	d	d	d	d	d	d	d	Data Word
Word 1 -	e	p	0	0	1	0	0	1	0	0	0	0	d	d	d	d	Command Word

Note: You must move material when performing Auto Cal. See *STX Installation and Operation Manual*.

Hi Span Cal (Auto Calibration)

Dec: 10 Hex: A Range: 0-999999

Input Table

Dec. Bit -	15	14	13	12	11	10	9	8	7	6	5	4	3	2	1	0	
Word 0 -	0	0	0	0	0	0	0	0	0	0	0	0	0	0	0	0	Data Word
Word 1 -	0	0	0	0	1	0	1	0	0	0	0	0	0	0	0	0	Command Word

Output Table

Dec. Bit -	15	14	13	12	11	10	9	8	7	6	5	4	3	2	1	0	
Word 0 -	d	d	d	d	d	d	d	d	d	d	d	d	d	d	d	d	Data Word
Word 1 -	e	p	0	0	1	0	1	0	0	0	0	0	d	d	d	d	Command Word

Note: You must move material when performing Auto Cal. See *STX Installation and Operation Manual*.

Scale Factor Counts (Manual Calibration)

Dec: 11 Hex: B Range: 0-2097151

Input Table

Dec. Bit -	15	14	13	12	11	10	9	8	7	6	5	4	3	2	1	0	
Word 0 -	0	0	0	0	0	0	0	0	0	0	0	0	0	0	0	0	Data Word
Word 1 -	0	0	0	0	1	0	1	1	0	0	0	0	0	0	0	0	Command Word

Output Table

Dec. Bit -	15	14	13	12	11	10	9	8	7	6	5	4	3	2	1	0	
Word 0 -	d	d	d	d	d	d	d	d	d	d	d	d	d	d	d	d	Data Word
Word 1 -	e	p	0	0	1	0	1	1	0	0	0	d	d	d	d	d	Command Word

Legend: Dec = # in decimal form; Hex = # in hexadecimal form; e = error; p = polarity; ddd... = data; D... = subcommand

Control Mode Commands: MVS-Modbus/STX

Scale Factor Weight (Manual Calibration)

Dec: 12 Hex: C Range: 0-999999

Input Table

Dec. Bit -	15	14	13	12	11	10	9	8	7	6	5	4	3	2	1	0
Word 0 -	0	0	0	0	0	0	0	0	0	0	0	0	0	0	0	0
Word 1 -	0	0	0	0	1	1	0	0	0	0	0	0	0	0	0	0

Data Word
Command Word

Output Table

Dec. Bit -	15	14	13	12	11	10	9	8	7	6	5	4	3	2	1	0
Word 0 -	d	d	d	d	d	d	d	d	d	d	d	d	d	d	d	d
Word 1 -	e	p	0	0	1	1	0	0	0	0	0	0	d	d	d	d

Data Word
Command Word

Zero Counts (Manual Calibration)

Dec: 13 Hex: D Range: 0-2097151

Input Table

Dec. Bit -	15	14	13	12	11	10	9	8	7	6	5	4	3	2	1	0
Word 0 -	0	0	0	0	0	0	0	0	0	0	0	0	0	0	0	0
Word 1 -	0	0	0	0	1	1	0	1	0	0	0	0	0	0	0	0

Data Word
Command Word

Output Table

Dec. Bit -	15	14	13	12	11	10	9	8	7	6	5	4	3	2	1	0
Word 0 -	d	d	d	d	d	d	d	d	d	d	d	d	d	d	d	d
Word 1 -	e	p	0	0	1	1	0	1	0	0	0	d	d	d	d	d

Data Word
Command Word

Excitation

Dec: 14 Hex: E Range: 0-255

Input Table

Dec. Bit -	15	14	13	12	11	10	9	8	7	6	5	4	3	2	1	0
Word 0 -	0	0	0	0	0	0	0	0	0	0	0	0	0	0	0	0
Word 1 -	0	0	0	0	1	1	1	0	0	0	0	0	0	0	0	0

Data Word
Command Word

Output Table

Dec. Bit -	15	14	13	12	11	10	9	8	7	6	5	4	3	2	1	0
Word 0 -	0	0	0	0	0	0	0	0	d	d	d	d	d	d	d	d
Word 1 -	e	p	0	0	1	1	1	0	0	0	0	0	0	0	0	0

Data Word
Command Word

Legend: Dec = # in decimal form; Hex = # in hexadecimal form; e = error; p = polarity; ddd... = data; D... = subcommand

Control Mode Commands: MVS-Modbus/STX

Analog/Digital Mode

Dec: 15 Hex: F Range: 0-1

Input Table

Dec. Bit -	15	14	13	12	11	10	9	8	7	6	5	4	3	2	1	0	
Word 0 -	0	0	0	0	0	0	0	0	0	0	0	0	0	0	0	0	Data Word
Word 1 -	0	0	0	0	1	1	1	1	0	0	0	0	0	0	0	0	Command Word

Output Table

Dec. Bit -	15	14	13	12	11	10	9	8	7	6	5	4	3	2	1	0	
Word 0 -	0	0	0	0	0	0	0	0	0	0	0	0	0	0	0	d	Data Word
Word 1 -	e	p	0	0	1	1	1	1	0	0	0	0	0	0	0	0	Command Word

Note: 0=digital mode, 1=analog mode

Averaging Factor

Dec: 16 Hex: 10 Range: 1-255

Input Table

Dec. Bit -	15	14	13	12	11	10	9	8	7	6	5	4	3	2	1	0	
Word 0 -	0	0	0	0	0	0	0	0	0	0	0	0	0	0	0	0	Data Word
Word 1 -	0	0	0	1	0	0	0	0	0	0	0	0	0	0	0	0	Command Word

Output Table

Dec. Bit -	15	14	13	12	11	10	9	8	7	6	5	4	3	2	1	0	
Word 0 -	0	0	0	0	0	0	0	0	d	d	d	d	d	d	d	d	Data Word
Word 1 -	e	p	0	1	0	0	0	0	0	0	0	0	0	0	0	0	Command Word

Note: 0=illegal

0/4 mA Mode

Dec: 17 Hex: 11 Range: 0-1

Input Table

Dec. Bit -	15	14	13	12	11	10	9	8	7	6	5	4	3	2	1	0	
Word 0 -	0	0	0	0	0	0	0	0	0	0	0	0	0	0	0	0	Data Word
Word 1 -	0	0	0	1	0	0	0	1	0	0	0	0	0	0	0	0	Command Word

Output Table

Dec. Bit -	15	14	13	12	11	10	9	8	7	6	5	4	3	2	1	0	
Word 0 -	0	0	0	0	0	0	0	0	0	0	0	0	0	0	0	d	Data Word
Word 1 -	e	p	0	1	0	0	0	1	0	0	0	0	0	0	0	0	Command Word

Note: 1=4/20 mode, 0=0/20 mode

Legend: Dec = # in decimal form; Hex = # in hexadecimal form; e = error; p = polarity; ddd... = data; D... = subcommand

Control Mode Commands: MVS-Modbus/STX

Lo mA Value

Dec: 18 Hex: 12 Range: 0-±999999

Input Table

Dec. Bit -	15	14	13	12	11	10	9	8	7	6	5	4	3	2	1	0
Word 0 -	0	0	0	0	0	0	0	0	0	0	0	0	0	0	0	0
Word 1 -	0	0	0	1	0	0	1	0	0	0	0	0	0	0	0	0

Data Word
Command Word

Output Table

Dec. Bit -	15	14	13	12	11	10	9	8	7	6	5	4	3	2	1	0
Word 0 -	d	d	d	d	d	d	d	d	d	d	d	d	d	d	d	d
Word 1 -	e	0	0	1	0	0	1	0	0	0	0	p	d	d	d	d

Data Word
Command Word

Note: When Net Mode is selected, Bit 4 of Command Word is polarity for the Lo mA value.

Hi mA Value

Dec: 19 Hex: 13 Range: 0-±999999

Input Table

Dec. Bit -	15	14	13	12	11	10	9	8	7	6	5	4	3	2	1	0
Word 0 -	0	0	0	0	0	0	0	0	0	0	0	0	0	0	0	0
Word 1 -	0	0	0	1	0	0	1	1	0	0	0	0	0	0	0	0

Data Word
Command Word

Output Table

Dec. Bit -	15	14	13	12	11	10	9	8	7	6	5	4	3	2	1	0
Word 0 -	d	d	d	d	d	d	d	d	d	d	d	d	d	d	d	d
Word 1 -	e	0	0	1	0	0	1	1	0	0	0	p	d	d	d	d

Data Word
Command Word

Note: When Net Mode is selected, Bit 4 of Command Word is polarity for the Hi mA value.

Net/Gross Mode for Current Output

Dec: 20 Hex: 14 Range: 0-1

Input Table

Dec. Bit -	15	14	13	12	11	10	9	8	7	6	5	4	3	2	1	0
Word 0 -	0	0	0	0	0	0	0	0	0	0	0	0	0	0	0	0
Word 1 -	0	0	0	1	0	1	0	0	0	0	0	0	0	0	0	0

Data Word
Command Word

Output Table

Dec. Bit -	15	14	13	12	11	10	9	8	7	6	5	4	3	2	1	0
Word 0 -	0	0	0	0	0	0	0	0	0	0	0	0	0	0	0	d
Word 1 -	e	p	0	1	0	1	0	0	0	0	0	0	0	0	0	0

Data Word
Command Word

Note: Bit 0 of data word: 0=gross, 1=net

Legend: Dec = # in decimal form; Hex = # in hexadecimal form; e = error; p = polarity; ddd... = data; D... = subcommand

Control Mode Commands: MVS-Modbus/STX

Failsafe for Current Output

Dec: 21 Hex: 15 Range: 0-2

Input Table

Dec. Bit -	15	14	13	12	11	10	9	8	7	6	5	4	3	2	1	0
Word 0 -	0	0	0	0	0	0	0	0	0	0	0	0	0	0	0	0
Word 1 -	0	0	0	1	0	1	0	1	0	0	0	0	0	0	0	0

Data Word
Command Word

Output Table

Dec. Bit -	15	14	13	12	11	10	9	8	7	6	5	4	3	2	1	0
Word 0 -	0	0	0	0	0	0	0	0	0	0	0	0	0	0	d	d
Word 1 -	e	p	0	1	0	1	0	1	0	0	0	0	0	0	0	0

Data Word
Command Word

Note: 0=Lo, 1=Hi, 2=No Change

0 mA Factory Calibration (local)

Dec: 22 Hex: 16 Range: 0-16383

Input Table

Dec. Bit -	15	14	13	12	11	10	9	8	7	6	5	4	3	2	1	0
Word 0 -	0	0	0	0	0	0	0	0	0	0	0	0	0	0	0	0
Word 1 -	0	0	0	1	0	1	1	0	0	0	0	0	0	0	0	0

Data Word
Command Word

Output Table

Dec. Bit -	15	14	13	12	11	10	9	8	7	6	5	4	3	2	1	0
Word 0 -	0	0	d	d	d	d	d	d	d	d	d	d	d	d	d	d
Word 1 -	e	p	0	1	0	1	1	0	0	0	0	0	0	0	0	0

Data Word
Command Word

4 mA Factory Calibration (local)

Dec: 23 Hex: 17 Range: 0-16383

Input Table

Dec. Bit -	15	14	13	12	11	10	9	8	7	6	5	4	3	2	1	0
Word 0 -	0	0	0	0	0	0	0	0	0	0	0	0	0	0	0	0
Word 1 -	0	0	0	1	0	1	1	1	0	0	0	0	0	0	0	0

Data Word
Command Word

Output Table

Dec. Bit -	15	14	13	12	11	10	9	8	7	6	5	4	3	2	1	0
Word 0 -	0	0	d	d	d	d	d	d	d	d	d	d	d	d	d	d
Word 1 -	e	p	0	1	0	1	1	1	0	0	0	0	0	0	0	0

Data Word
Command Word

Legend: Dec = # in decimal form; Hex = # in hexadecimal form; e = error; p = polarity; ddd... = data; D... = subcommand

Control Mode Commands: MVS-Modbus/STX

20 mA Factory Calibration (local)

Dec: 24 Hex: 18 Range: 0-16383

Input Table

Dec. Bit -	15	14	13	12	11	10	9	8	7	6	5	4	3	2	1	0
Word 0 -	0	0	0	0	0	0	0	0	0	0	0	0	0	0	0	0
Word 1 -	0	0	0	1	1	0	0	0	0	0	0	0	0	0	0	0

Data Word
Command Word

Output Table

Dec. Bit -	15	14	13	12	11	10	9	8	7	6	5	4	3	2	1	0
Word 0 -	0	0	d	d	d	d	d	d	d	d	d	d	d	d	d	d
Word 1 -	e	p	0	1	1	0	0	0	0	0	0	0	0	0	0	0

Data Word
Command Word

Raw Input Counts (Linearization Table)

Dec: 30 Hex: 1E Range: 0-2097151

Input Table

Dec. Bit -	15	14	13	12	11	10	9	8	7	6	5	4	3	2	1	0
Word 0 -	0	0	0	0	0	0	0	0	0	0	0	0	0	0	0	0
Word 1 -	0	0	0	1	1	1	1	0	D	D	D	0	0	0	0	0

Data Word
Command Word

Output Table

Dec. Bit -	15	14	13	12	11	10	9	8	7	6	5	4	3	2	1	0
Word 0 -	d	d	d	d	d	d	d	d	d	d	d	d	d	d	d	d
Word 1 -	e	p	0	1	1	1	1	0	0	0	0	d	d	d	d	d

Data Word
Command Word

Note: Command Word Bits 5, 6, and 7 are the Linear Table entry number (0=1st, 1=2nd, 2=3rd, 3=4th, and 4=5th)

Corrected Output Counts (Linearization Table)

Dec: 31 Hex: 1F Range: 0-2097151

Input Table

Dec. Bit -	15	14	13	12	11	10	9	8	7	6	5	4	3	2	1	0
Word 0 -	0	0	0	0	0	0	0	0	0	0	0	0	0	0	0	0
Word 1 -	0	0	0	1	1	1	1	1	D	D	D	0	0	0	0	0

Data Word
Command Word

Output Table

Dec. Bit -	15	14	13	12	11	10	9	8	7	6	5	4	3	2	1	0
Word 0 -	d	d	d	d	d	d	d	d	d	d	d	d	d	d	d	d
Word 1 -	e	p	0	1	1	1	1	1	0	0	0	d	d	d	d	d

Data Word
Command Word

Note: Command Word Bits 5, 6, and 7 are the Linear Table entry number (0=1st, 1=2nd, 2=3rd, 3=4th, and 4=5th)

Legend: Dec = # in decimal form; Hex = # in hexadecimal form; e = error; p = polarity; ddd... = data; D... = subcommand

Control Mode Commands: MVS-Modbus/STX

Linearization Enable

Dec: 32 Hex: 20 Range: 0-1

Input Table

Dec. Bit -	15	14	13	12	11	10	9	8	7	6	5	4	3	2	1	0
Word 0 -	0	0	0	0	0	0	0	0	0	0	0	0	0	0	0	0
Word 1 -	0	0	1	0	0	0	0	0	0	0	0	0	0	0	0	0

Data Word
Command Word

Output Table

Dec. Bit -	15	14	13	12	11	10	9	8	7	6	5	4	3	2	1	0
Word 0 -	0	0	0	0	0	0	0	0	0	0	0	0	0	0	0	d
Word 1 -	e	p	1	0	0	0	0	0	0	0	0	0	0	0	0	0

Data Word
Command Word

Note: Bit 0 of data word: 0=disable, 1=enable

Raw A/D Counts (read only)

Dec: 33 Hex: 21 Range: 0-2097151

Input Table

Dec. Bit -	15	14	13	12	11	10	9	8	7	6	5	4	3	2	1	0
Word 0 -	0	0	0	0	0	0	0	0	0	0	0	0	0	0	0	0
Word 1 -	0	0	1	0	0	0	0	1	0	0	0	0	0	0	0	0

Data Word
Command Word

Output Table

Dec. Bit -	15	14	13	12	11	10	9	8	7	6	5	4	3	2	1	0
Word 0 -	d	d	d	d	d	d	d	d	d	d	d	d	d	d	d	d
Word 1 -	e	p	1	0	0	0	0	1	0	0	0	d	d	d	d	d

Data Word
Command Word

Legend: Dec = # in decimal form; Hex = # in hexadecimal form; e = error; p = polarity; ddd... = data; D... = subcommand

Chapter 9. Commands for MVS-Modbus/ Models 1000 and 1020

Quick Command Reference Table for MVS-Modbus/Models 1000 and 1020

1000 & 1020 Parameters	Command		Range	Comments	Page No.
	Dec	Hex			
Gross Weight	1	1	0-9999	Value in selected engineering units	9-2
Net Weight	2	2	0-±9999	Model 1020 only; value in selected eng units	9-2
Tare	6	6	—	Model 1020 only	9-2
Status (includes errors)	7	7	0-255		9-3

Note

Refer to Chapter 4 for general information on programming.

Control Mode Commands: MVS-Modbus/Models 1000 and 1020

Gross Weight (read only)

Dec: 1 Hex: 1 Range: 0-9999

Input Table

Dec. Bit -	15	14	13	12	11	10	9	8	7	6	5	4	3	2	1	0
Word 0 -	0	0	0	0	0	0	0	0	0	0	0	0	0	0	0	0
Word 1 -	0	0	0	0	0	0	0	1	0	0	0	0	0	0	0	0

Data Word
Command Word

Output Table

Dec. Bit -	15	14	13	12	11	10	9	8	7	6	5	4	3	2	1	0
Word 0 -	0	0	d	d	d	d	d	d	d	d	d	d	d	d	d	d
Word 1 -	e	p	0	0	0	0	0	1	0	0	0	0	0	0	0	0

Data Word
Command Word

Net Weight (read only) — Model 1020 only

Dec: 2 Hex: 2 Range: 0-±9999

Input Table

Dec. Bit -	15	14	13	12	11	10	9	8	7	6	5	4	3	2	1	0
Word 0 -	0	0	0	0	0	0	0	0	0	0	0	0	0	0	0	0
Word 1 -	0	0	0	0	0	0	1	0	0	0	0	0	0	0	0	0

Data Word
Command Word

Output Table

Dec. Bit -	15	14	13	12	11	10	9	8	7	6	5	4	3	2	1	0
Word 0 -	0	0	d	d	d	d	d	d	d	d	d	d	d	d	d	d
Word 1 -	e	p	0	0	0	0	1	0	0	0	0	0	0	0	0	0

Data Word
Command Word

Tare (set only) — Model 1020 only

Dec: 6 Hex: 6 Range: N/A

Input Table

Dec. Bit -	15	14	13	12	11	10	9	8	7	6	5	4	3	2	1	0
Word 0 -	0	0	0	0	0	0	0	0	0	0	0	0	0	0	0	1
Word 1 -	1	0	0	0	0	1	1	0	0	0	0	0	0	0	0	0

Data Word
Command Word

Output Table

Dec. Bit -	15	14	13	12	11	10	9	8	7	6	5	4	3	2	1	0
Word 0 -	0	0	0	0	0	0	0	0	0	0	0	0	0	0	0	0
Word 1 -	e	p	0	0	0	1	1	0	0	0	0	0	0	0	0	0

Data Word
Command Word

Note: To set tare, set bit 0 of Data Word to 1 and use the Write bit.

Legend: Dec = # in decimal form; Hex = # in hexadecimal form; e = error; p = polarity; ddd... = data; D... = subcommand

Control Mode Commands: MVS-Modbus/Models 1000 and 1020

Status (read only)

Dec: 7 Hex: 7 Range: 0-255

Input Table

Dec. Bit -	15	14	13	12	11	10	9	8	7	6	5	4	3	2	1	0	
Word 0 -	0	0	0	0	0	0	0	0	0	0	0	0	0	0	0	0	Data Word
Word 1 -	0	0	0	0	0	1	1	1	0	0	0	0	0	0	0	0	Command Word

Output Table

Dec. Bit -	15	14	13	12	11	10	9	8	7	6	5	4	3	2	1	0	
Word 0 -	d	d	d	d	d	d	d	d	0	0	0	0	0	0	0	0	Data Word
Word 1 -	e	p	0	0	0	1	1	1	0	0	0	0	0	0	0	0	Command Word

Notes: Description of status (bits 8-15 of data word)

Bit 8 - Net units negative

Bit 9 - N/A

Bit 10 - N/A

Bit 11 - N/A

Bit 12 - COM error condition

Bit 13 - Analog input overrange

Bit 14 - Engineering unit overflow

Bit 15 - Gross units negative

Legend: Dec = # in decimal form; Hex = # in hexadecimal form; e = error; p = polarity; ddd... = data; D... = subcommand

Chapter 10. Commands for MVS-Modbus/Sonologic II & ultra-wave™

Quick Command Reference Table for MVS-Modbus with Sonologic II & ultra-wave™

Sono II & ultra-wave Parameters	Command		Range	Comments	Page No.
	Dec	Hex			
Level Data	1	1	0-65535	Material mode: level/head (flow apps.) Air Space mode: air space	10-2
Flow Data	2	2	0-65535	For flow applications only	10-2
Main Totalizer Low Word	3	3	0-65535	For flow applications only	10-2
Main Totalizer High Word	4	4	0-65535	For flow applications only	10-3
Status (includes errors)	7	7	0-255		10-3
Full Point	8	8	0-9999	If polarity bit is 1, value is negative	10-3
Operating Span	9	9	0-65535		10-4
Standard Display Format	10	A	0-14	0=ft, 1=0.1ft, 2=0.01ft, 4=in, 5=0.1in, 6=0.01in, 8=m, 9=0.1m, 10=0.01m, 11=0.001m, 12=cm, 13=0.1cm, 14=0.01cm	10-4
Air/Material Mode	11	B	0-1	0=air space mode, 1=material mode	10-4
Window	12	C	0-65535	In standard display units/format	10-5
Minimum Range	13	D	0-65535	In standard display units/format	10-5
Maximum Range	14	E	0-65535	In standard display units/format	10-5
Special Display Units	15	F	0-65535	Maximum value of special display unit	10-6
Averaging Factor	16	10	1-255		10-6
Echo Loss Timer	20	14	0-65535		10-6
Power	22	16	0-1000	0 to 100.0%	10-7
Near Gain	23	17	0-10000	0 to 100.00%	10-7
Echo Detection Threshold	24	18	0-1000	0 to 100.0%	10-7
Peak Detection Threshold	25	19	0-1000	0 to 100.0%	10-8
Active TVG	26	1A	0-10000	0 to 100.00%	10-8
TVG High Limit	27	1B	0-10000	0 to 100.00%	10-8
TVG Low Limit	28	1C	0-10000	0 to 100.00%	10-9
Transmit Cycles	29	1D	0-100	Transmit burst in cycles	10-9
Raw Target in Inches (cm)	35	23	0-65535	To .01 inches or .01 cm (format xxx.xx)	10-9
Application Type	39	27	0-99	0=level, 1=flow, 3=differential level detection, 99=math channel	10-10
Force Setpoint Mode ^{1,2,3}	45	2D	0-2		10-10

Notes:

- Bits 4, 5, and 6 of Command Word is the setpoint number (000=Setpoint 1 through 111=Setpoint 8).
- To activate the Force Mode, set bit 1 of Data Word to 1 and set the Write bit to 1. To deactivate the Force Mode, set bit 1 of the Data Word to 0 and set the Write bit to 1.
- Bit 0 of Data Word represents the state of the setpoint (1=On, 0=Off) when the Force Mode is active. When the Force Mode is inactive, the setpoint is controlled by the Sono II microprocessor card.

CAUTION

The Force Setpoint Mode command removes control of the setpoint from the Sono II/u-w and gives it to the PLC. The Sono II/u-w will not update the setpoint when this mode is active.

Note

Refer to Chapter 4 for general information on programming.

Control Mode Commands: MVS-Modbus/Sono II & ultra-wave™

Level Data (read only)

Dec: 1 Hex: 1 Range: 0-65535

Input Table

Dec. Bit -	15	14	13	12	11	10	9	8	7	6	5	4	3	2	1	0
Word 0 -	0	0	0	0	0	0	0	0	0	0	0	0	0	0	0	0
Word 1 -	0	0	0	0	0	0	0	1	0	0	0	0	0	0	0	0

Data Word
Command Word

Output Table

Dec. Bit -	15	14	13	12	11	10	9	8	7	6	5	4	3	2	1	0
Word 0 -	d	d	d	d	d	d	d	d	d	d	d	d	d	d	d	d
Word 1 -	e	p	0	0	0	0	0	1	0	0	0	0	0	0	0	0

Data Word
Command Word

Flow Data (read only) — flow applications only

Dec: 2 Hex: 2 Range: 0-65535

Input Table

Dec. Bit -	15	14	13	12	11	10	9	8	7	6	5	4	3	2	1	0
Word 0 -	0	0	0	0	0	0	0	0	0	0	0	0	0	0	0	0
Word 1 -	0	0	0	0	0	0	1	0	0	0	0	0	0	0	0	0

Data Word
Command Word

Output Table

Dec. Bit -	15	14	13	12	11	10	9	8	7	6	5	4	3	2	1	0
Word 0 -	d	d	d	d	d	d	d	d	d	d	d	d	d	d	d	d
Word 1 -	e	p	0	0	0	0	1	0	0	0	0	0	0	0	0	0

Data Word
Command Word

Main Totalizer Low Word (read only) — flow applications only

Dec: 3 Hex: 3 Range: 0-65535

Input Table

Dec. Bit -	15	14	13	12	11	10	9	8	7	6	5	4	3	2	1	0
Word 0 -	0	0	0	0	0	0	0	0	0	0	0	0	0	0	0	0
Word 1 -	0	0	0	0	0	0	1	1	0	0	0	0	0	0	0	0

Data Word
Command Word

Output Table

Dec. Bit -	15	14	13	12	11	10	9	8	7	6	5	4	3	2	1	0
Word 0 -	d	d	d	d	d	d	d	d	d	d	d	d	d	d	d	d
Word 1 -	e	p	0	0	0	0	1	1	0	0	0	0	0	0	0	0

Data Word
Command Word

Legend: Dec = # in decimal form; Hex = # in hexadecimal form; e = error; p = polarity; ddd... = data; D... = subcommand

Control Mode Commands: MVS-Modbus/Sono II & ultra-wave™**Main Totalizer High Word (read only) — flow applications only**

Dec: 4 Hex: 4 Range: 0-65535

Input Table

Dec. Bit -	15	14	13	12	11	10	9	8	7	6	5	4	3	2	1	0
Word 0 -	0	0	0	0	0	0	0	0	0	0	0	0	0	0	0	0
Word 1 -	0	0	0	0	0	1	0	0	0	0	0	0	0	0	0	0

Data Word
Command Word

Output Table

Dec. Bit -	15	14	13	12	11	10	9	8	7	6	5	4	3	2	1	0
Word 0 -	d	d	d	d	d	d	d	d	d	d	d	d	d	d	d	d
Word 1 -	e	p	0	0	0	1	0	0	0	0	0	0	0	0	0	0

Data Word
Command Word

Status (read only)

Dec: 7 Hex: 7 Range: 0-255

Input Table

Dec. Bit -	15	14	13	12	11	10	9	8	7	6	5	4	3	2	1	0
Word 0 -	0	0	0	0	0	0	0	0	0	0	0	0	0	0	0	0
Word 1 -	0	0	0	0	0	1	1	1	0	0	0	0	0	0	0	0

Data Word
Command Word

Output Table

Dec. Bit -	15	14	13	12	11	10	9	8	7	6	5	4	3	2	1	0
Word 0 -	d	d	d	d	d	d	d	d	0	0	0	0	0	0	0	0
Word 1 -	e	p	0	0	0	1	1	1	0	0	0	0	0	0	0	0

Data Word
Command Word

Notes: Description of status (bits 8-15 of data word)

Bit 8 -N/A

Bit 12 - COM error condition

Bit 9 - Echo Loss

Bit 13 - Requested setpoint or current output not assigned

Bit 10 -Math computation error or
over-temperature condition

Bit 14 - Eng. unit overflow

Bit 15 - N/A

Bit 11 - Illegal average factor

Full Point

Dec: 8 Hex: 8 Range: 0-9999

Input Table

Dec. Bit -	15	14	13	12	11	10	9	8	7	6	5	4	3	2	1	0
Word 0 -	0	0	0	0	0	0	0	0	0	0	0	0	0	0	0	0
Word 1 -	0	0	0	0	1	0	0	0	0	0	0	0	0	0	0	0

Data Word
Command Word

Output Table

Dec. Bit -	15	14	13	12	11	10	9	8	7	6	5	4	3	2	1	0
Word 0 -	0	0	d	d	d	d	d	d	d	d	d	d	d	d	d	d
Word 1 -	e	p	0	0	1	0	0	0	0	0	0	0	0	0	0	0

Data Word
Command Word

Legend: Dec = # in decimal form; Hex = # in hexadecimal form; e = error; p = polarity; ddd... = data; D... = subcommand

Control Mode Commands: MVS-Modbus/Sono II & ultra-wave™

Operating Span

Dec: 9 Hex: 9 Range: 0-65535

Input Table

Dec. Bit -	15	14	13	12	11	10	9	8	7	6	5	4	3	2	1	0
Word 0 -	0	0	0	0	0	0	0	0	0	0	0	0	0	0	0	0
Word 1 -	0	0	0	0	1	0	0	1	0	0	0	0	0	0	0	0

Data Word
Command Word

Output Table

Dec. Bit -	15	14	13	12	11	10	9	8	7	6	5	4	3	2	1	0
Word 0 -	d	d	d	d	d	d	d	d	d	d	d	d	d	d	d	d
Word 1 -	e	p	0	0	1	0	0	1	0	0	0	0	0	0	0	0

Data Word
Command Word

Standard Display Format

Dec: 10 Hex: A Range: 0-14

Input Table

Dec. Bit -	15	14	13	12	11	10	9	8	7	6	5	4	3	2	1	0
Word 0 -	0	0	0	0	0	0	0	0	0	0	0	0	0	0	0	0
Word 1 -	0	0	0	0	1	0	1	0	0	0	0	0	0	0	0	0

Data Word
Command Word

Output Table

Dec. Bit -	15	14	13	12	11	10	9	8	7	6	5	4	3	2	1	0
Word 0 -	0	0	0	0	0	0	0	0	0	0	0	0	d	d	d	d
Word 1 -	e	p	0	0	1	0	1	0	0	0	0	0	0	0	0	0

Data Word
Command Word

Note: 0=ft, 1=0.1 ft, 2=0.01 ft, 4=in, 5=0.1 in, 6=0.01 in, 8=m, 9=0.1 m, 10=0.01m, 11=0.001m, 12=cm, 13=0.1 cm, 14=0.01 cm

Air/Material Mode

Dec: 11 Hex: B Range: 0-1

Input Table

Dec. Bit -	15	14	13	12	11	10	9	8	7	6	5	4	3	2	1	0
Word 0 -	0	0	0	0	0	0	0	0	0	0	0	0	0	0	0	0
Word 1 -	0	0	0	0	1	0	1	1	0	0	0	0	0	0	0	0

Data Word
Command Word

Output Table

Dec. Bit -	15	14	13	12	11	10	9	8	7	6	5	4	3	2	1	0
Word 0 -	0	0	0	0	0	0	0	0	0	0	0	0	0	0	0	d
Word 1 -	e	p	0	0	1	0	1	1	0	0	0	0	0	0	0	0

Data Word
Command Word

Note: 0 = air space mode, 1 = material mode

Legend: Dec = # in decimal form; Hex = # in hexadecimal form; e = error; p = polarity; ddd... = data; D... = subcommand

Control Mode Commands: MVS-Modbus/Sono II & ultra-wave™**Window**

Dec: 12 Hex: C Range: 0-65535

Input Table

Dec. Bit -	15	14	13	12	11	10	9	8	7	6	5	4	3	2	1	0
Word 0 -	0	0	0	0	0	0	0	0	0	0	0	0	0	0	0	0
Word 1 -	0	0	0	0	1	1	0	0	0	0	0	0	0	0	0	0

Data Word
Command Word

Output Table

Dec. Bit -	15	14	13	12	11	10	9	8	7	6	5	4	3	2	1	0
Word 0 -	d	d	d	d	d	d	d	d	d	d	d	d	d	d	d	d
Word 1 -	e	p	0	0	1	1	0	0	0	0	0	0	0	0	0	0

Data Word
Command Word

Minimum Range

Dec: 13 Hex: D Range: 0-65535

Input Table

Dec. Bit -	15	14	13	12	11	10	9	8	7	6	5	4	3	2	1	0
Word 0 -	0	0	0	0	0	0	0	0	0	0	0	0	0	0	0	0
Word 1 -	0	0	0	0	1	1	0	1	0	0	0	0	0	0	0	0

Data Word
Command Word

Output Table

Dec. Bit -	15	14	13	12	11	10	9	8	7	6	5	4	3	2	1	0
Word 0 -	d	d	d	d	d	d	d	d	d	d	d	d	d	d	d	d
Word 1 -	e	p	0	0	1	1	0	1	0	0	0	0	0	0	0	0

Data Word
Command Word

Maximum Range

Dec: 14 Hex: E Range: 0-65535

Input Table

Dec. Bit -	15	14	13	12	11	10	9	8	7	6	5	4	3	2	1	0
Word 0 -	0	0	0	0	0	0	0	0	0	0	0	0	0	0	0	0
Word 1 -	0	0	0	0	1	1	1	0	0	0	0	0	0	0	0	0

Data Word
Command Word

Output Table

Dec. Bit -	15	14	13	12	11	10	9	8	7	6	5	4	3	2	1	0
Word 0 -	d	d	d	d	d	d	d	d	d	d	d	d	d	d	d	d
Word 1 -	e	p	0	0	1	1	1	0	0	0	0	0	0	0	0	0

Data Word
Command Word

Legend: Dec = # in decimal form; Hex = # in hexadecimal form; e = error; p = polarity; ddd... = data; D... = subcommand

Control Mode Commands: MVS-Modbus/Sono II & ultra-wave™

Special Display Units (maximum value)

Dec: 15 Hex: F Range: 0-65535

Input Table

Dec. Bit -	15	14	13	12	11	10	9	8	7	6	5	4	3	2	1	0	
Word 0 -	0	0	0	0	0	0	0	0	0	0	0	0	0	0	0	0	Data Word
Word 1 -	0	0	0	0	1	1	1	1	0	0	0	0	0	0	0	0	Command Word

Output Table

Dec. Bit -	15	14	13	12	11	10	9	8	7	6	5	4	3	2	1	0	
Word 0 -	d	d	d	d	d	d	d	d	d	d	d	d	d	d	d	d	Data Word
Word 1 -	e	p	0	0	1	1	1	1	0	0	0	0	0	0	0	0	Command Word

Averaging Factor

Dec: 16 Hex: 10 Range: 1-255

Input Table

Dec. Bit -	15	14	13	12	11	10	9	8	7	6	5	4	3	2	1	0	
Word 0 -	0	0	0	0	0	0	0	0	0	0	0	0	0	0	0	0	Data Word
Word 1 -	0	0	0	1	0	0	0	0	0	0	0	0	0	0	0	0	Command Word

Output Table

Dec. Bit -	15	14	13	12	11	10	9	8	7	6	5	4	3	2	1	0	
Word 0 -	0	0	0	0	0	0	0	0	d	d	d	d	d	d	d	d	Data Word
Word 1 -	e	p	0	1	0	0	0	0	0	0	0	0	0	0	0	0	Command Word

Echo Loss Timer

Dec: 20 Hex: 14 Range: 0-65535

Input Table

Dec. Bit -	15	14	13	12	11	10	9	8	7	6	5	4	3	2	1	0	
Word 0 -	0	0	0	0	0	0	0	0	0	0	0	0	0	0	0	0	Data Word
Word 1 -	0	0	0	1	0	1	0	0	0	0	0	0	0	0	0	0	Command Word

Output Table

Dec. Bit -	15	14	13	12	11	10	9	8	7	6	5	4	3	2	1	0	
Word 0 -	d	d	d	d	d	d	d	d	d	d	d	d	d	d	d	d	Data Word
Word 1 -	e	p	0	1	0	1	0	0	0	0	0	0	0	0	0	0	Command Word

Legend: Dec = # in decimal form; Hex = # in hexadecimal form; e = error; p = polarity; ddd... = data; D... = subcommand

Control Mode Commands: MVS-Modbus/Sono II & ultra-wave™**Power**

Dec: 22 Hex: 16 Range: 0-1000 (100.0%)

Input Table

Dec. Bit -	15	14	13	12	11	10	9	8	7	6	5	4	3	2	1	0
Word 0 -	0	0	0	0	0	0	0	0	0	0	0	0	0	0	0	0
Word 1 -	0	0	0	1	0	1	1	0	0	0	0	0	0	0	0	0

Data Word
Command Word

Output Table

Dec. Bit -	15	14	13	12	11	10	9	8	7	6	5	4	3	2	1	0
Word 0 -	0	0	0	0	0	0	d	d	d	d	d	d	d	d	d	d
Word 1 -	e	p	0	1	0	1	1	0	0	0	0	0	0	0	0	0

Data Word
Command Word

Near Gain

Dec: 23 Hex: 17 Range: 0-10000 (100.00%)

Input Table

Dec. Bit -	15	14	13	12	11	10	9	8	7	6	5	4	3	2	1	0
Word 0 -	0	0	0	0	0	0	0	0	0	0	0	0	0	0	0	0
Word 1 -	0	0	0	1	0	1	1	1	0	0	0	0	0	0	0	0

Data Word
Command Word

Output Table

Dec. Bit -	15	14	13	12	11	10	9	8	7	6	5	4	3	2	1	0
Word 0 -	0	0	d	d	d	d	d	d	d	d	d	d	d	d	d	d
Word 1 -	e	p	0	1	0	1	1	1	0	0	0	0	0	0	0	0

Data Word
Command Word

Echo Detection Threshold

Dec: 24 Hex: 18 Range: 0-1000 (100.0%)

Input Table

Dec. Bit -	15	14	13	12	11	10	9	8	7	6	5	4	3	2	1	0
Word 0 -	0	0	0	0	0	0	0	0	0	0	0	0	0	0	0	0
Word 1 -	0	0	0	1	1	0	0	0	0	0	0	0	0	0	0	0

Data Word
Command Word

Output Table

Dec. Bit -	15	14	13	12	11	10	9	8	7	6	5	4	3	2	1	0
Word 0 -	0	0	0	0	0	0	d	d	d	d	d	d	d	d	d	d
Word 1 -	e	p	0	1	1	0	0	0	0	0	0	0	0	0	0	0

Data Word
Command Word

Legend: Dec = # in decimal form; Hex = # in hexadecimal form; e = error; p = polarity; ddd... = data; D... = subcommand

Control Mode Commands: MVS-Modbus/Sono II & ultra-wave™

Peak Detection Threshold

Dec: 25 Hex: 19 Range: 0-1000 (100.0%)

Input Table

Dec. Bit -	15	14	13	12	11	10	9	8	7	6	5	4	3	2	1	0
Word 0 -	0	0	0	0	0	0	0	0	0	0	0	0	0	0	0	0
Word 1 -	0	0	0	1	1	0	0	1	0	0	0	0	0	0	0	0

Data Word
Command Word

Output Table

Dec. Bit -	15	14	13	12	11	10	9	8	7	6	5	4	3	2	1	0
Word 0 -	0	0	0	0	0	0	d	d	d	d	d	d	d	d	d	d
Word 1 -	e	p	0	1	1	0	0	1	0	0	0	0	0	0	0	0

Data Word
Command Word

Active TVG (read only)

Dec: 26 Hex: 1A Range: 0-10000 (100.00%)

Input Table

Dec. Bit -	15	14	13	12	11	10	9	8	7	6	5	4	3	2	1	0
Word 0 -	0	0	0	0	0	0	0	0	0	0	0	0	0	0	0	0
Word 1 -	0	0	0	1	1	0	1	0	0	0	0	0	0	0	0	0

Data Word
Command Word

Output Table

Dec. Bit -	15	14	13	12	11	10	9	8	7	6	5	4	3	2	1	0
Word 0 -	0	0	d	d	d	d	d	d	d	d	d	d	d	d	d	d
Word 1 -	e	p	0	1	1	0	1	0	0	0	0	0	0	0	0	0

Data Word
Command Word

TVG High Limit

Dec: 27 Hex: 1B Range: 0-10000 (100.00%)

Input Table

Dec. Bit -	15	14	13	12	11	10	9	8	7	6	5	4	3	2	1	0
Word 0 -	0	0	0	0	0	0	0	0	0	0	0	0	0	0	0	0
Word 1 -	0	0	0	1	1	0	1	1	0	0	0	0	0	0	0	0

Data Word
Command Word

Output Table

Dec. Bit -	15	14	13	12	11	10	9	8	7	6	5	4	3	2	1	0
Word 0 -	0	0	d	d	d	d	d	d	d	d	d	d	d	d	d	d
Word 1 -	e	p	0	1	1	0	1	1	0	0	0	0	0	0	0	0

Data Word
Command Word

Legend: Dec = # in decimal form; Hex = # in hexadecimal form; e = error; p = polarity; ddd... = data; D... = subcommand

Control Mode Commands: MVS-Modbus/Sono II & ultra-wave™**TVG Low Limit**

Dec: 28 Hex: 1C Range: 0-10000 (100.00%)

Input Table

Dec. Bit -	15	14	13	12	11	10	9	8	7	6	5	4	3	2	1	0
Word 0 -	0	0	0	0	0	0	0	0	0	0	0	0	0	0	0	0
Word 1 -	0	0	0	1	1	1	0	0	0	0	0	0	0	0	0	0

Data Word
Command Word

Output Table

Dec. Bit -	15	14	13	12	11	10	9	8	7	6	5	4	3	2	1	0
Word 0 -	0	0	d	d	d	d	d	d	d	d	d	d	d	d	d	d
Word 1 -	e	p	0	1	1	1	0	0	0	0	0	0	0	0	0	0

Data Word
Command Word

Transmit Cycles

Dec: 29 Hex: 1D Range: 0-100

Input Table

Dec. Bit -	15	14	13	12	11	10	9	8	7	6	5	4	3	2	1	0
Word 0 -	0	0	0	0	0	0	0	0	0	0	0	0	0	0	0	0
Word 1 -	0	0	0	1	1	1	0	1	0	0	0	0	0	0	0	0

Data Word
Command Word

Output Table

Dec. Bit -	15	14	13	12	11	10	9	8	7	6	5	4	3	2	1	0
Word 0 -	0	0	0	0	0	0	0	0	0	d	d	d	d	d	d	d
Word 1 -	e	p	0	1	1	1	0	1	0	0	0	0	0	0	0	0

Data Word
Command Word

Raw Target in Inches (centimeters) (read only)

Dec: 35 Hex: 23 Range: 0-65535

Input Table

Dec. Bit -	15	14	13	12	11	10	9	8	7	6	5	4	3	2	1	0
Word 0 -	0	0	0	0	0	0	0	0	0	0	0	0	0	0	0	0
Word 1 -	0	0	1	0	0	0	1	1	0	0	0	0	0	0	0	0

Data Word
Command Word

Output Table

Dec. Bit -	15	14	13	12	11	10	9	8	7	6	5	4	3	2	1	0
Word 0 -	d	d	d	d	d	d	d	d	d	d	d	d	d	d	d	d
Word 1 -	e	p	1	0	0	0	1	1	0	0	0	0	0	0	0	0

Data Word
Command Word

Note: To .01 inches or .01 cm (format xxx.xx)

Legend: Dec = # in decimal form; Hex = # in hexadecimal form; e = error; p = polarity; ddd... = data; D... = subcommand

Control Mode Commands: MVS-Modbus/Sono II & ultra-wave™

Application Type (read only)

Dec: 39 Hex: 27 Range: 0-99

Input Table

Dec. Bit -	15	14	13	12	11	10	9	8	7	6	5	4	3	2	1	0	
Word 0 -	0	0	0	0	0	0	0	0	0	0	0	0	0	0	0	0	Data Word
Word 1 -	0	0	1	0	0	1	1	1	0	0	0	0	0	0	0	0	Command Word

Output Table

Dec. Bit -	15	14	13	12	11	10	9	8	7	6	5	4	3	2	1	0	
Word 0 -	0	0	0	0	0	0	0	0	0	d	d	d	d	d	d	d	Data Word
Word 1 -	e	p	1	0	0	1	1	1	0	0	0	0	0	0	0	0	Command Word

Notes: 0 = level, 1 = flow, 3 = differential level detection, 99 = math channel

Force Setpoint Mode (set only)

Dec: 45 Hex: 2D Range: 0-2

Input Table

Dec. Bit -	15	14	13	12	11	10	9	8	7	6	5	4	3	2	1	0	
Word 0 -	0	0	0	0	0	0	0	0	0	0	0	0	0	0	1	d	Data Word
Word 1 -	1	0	1	0	1	1	0	1	0	D	D	D	0	0	0	0	Command Word

Output Table

Dec. Bit -	15	14	13	12	11	10	9	8	7	6	5	4	3	2	1	0	
Word 0 -	0	0	0	0	0	0	0	0	0	0	0	0	0	0	0	0	Data Word
Word 1 -	0	0	1	0	1	1	0	1	0	0	0	0	0	0	0	0	Command Word

Notes:

- Bits 4, 5, and 6 are the setpoint number (000=Setpoint 1 through 111=Setpoint 8).
- To activate the Force Mode, set bit 1 of the Data Word to 1 and set the write bit (bit 15 of Command Word) to 1. To deactivate the Force Mode, set bit 1 of the Data Word to 0 and set the write bit to 1.
- Bit 0 of the Data Word represents the state of the setpoint (1=On, 0=Off) when the Force Mode is active. When the force mode is inactive, the setpoint is controlled by the Sono II microprocessor card.

CAUTION

The Force Setpoint Mode command removes control of the indicated setpoint from the Sono II /u-w and gives it to the PLC. The Sono II / u-w does not activate the setpoints based on the input value (for example: level, head, flow, etc.) when the Force Setpoint Mode is active.

Chapter 11. Commands for MVS-Modbus/Weigh II

Quick Command Reference Table for MVS-Modbus/Weigh II

Weigh II Parameters	Command		Range	Comments	Page No.
	Dec	Hex			
Gross Weight	1	1	0-999999	Value in selected engineering units	11-2
Net Weight	2	2	0-±999999	Value in selected engineering units	11-2
Tare	6	6	—		11-2
Status (includes errors)	7	7	0-255		11-3
Zero Cal (Auto)	8	8	0-999999	Value in selected engineering units	11-3
Lo Span Cal (Auto)	9	9	0-999999	Value in selected engineering units	11-3
Hi Span Cal (Auto)	10	A	0-999999	Value in selected engineering units	11-4
Scale Factor Cnts (Manual)	11	B	0-2097151		11-4
Scale Factor Wt (Manual)	12	C	0-999999	Value in selected engineering units	11-4
Zero Counts (Manual)	13	D	0-2097151		11-5
Excitation	14	E	0-255		11-5
Averaging Factor	16	10	1-255		11-5
Raw Input Counts	30	1E	0-2097151	For linearization table. Bits 5, 6, & 7 of Command Word is Linear Table Entry Number: 0=1st, 1=2nd, 2=3rd, 3=4th, 4=5th	11-6
Corrected Output Counts	31	1F	0-2097151	For linearization table. Bits 5, 6, & 7 of Command Word is Linear Table Entry Number: 0=1st, 1=2nd, 2=3rd, 3=4th, 4=5th	11-6
Linearization Enable	32	20	0-1	0=linearization off, 1=linearization on	11-6
Raw A/D Counts	33	21	0-2097151		11-7
Application Type	39	27	0-99	0=weight device, 99=math channel	11-7

Note

Refer to Chapter 4 for general information on programming.

Control Mode Commands: MVS-Modbus/Weigh II

Gross Weight (read only)

Dec: 1 Hex: 1 Range: 0-999999

Input Table

Dec. Bit -	15	14	13	12	11	10	9	8	7	6	5	4	3	2	1	0
Word 0 -	0	0	0	0	0	0	0	0	0	0	0	0	0	0	0	0
Word 1 -	0	0	0	0	0	0	0	1	0	0	0	0	0	0	0	0

Data Word
Command Word

Output Table

Dec. Bit -	15	14	13	12	11	10	9	8	7	6	5	4	3	2	1	0
Word 0 -	d	d	d	d	d	d	d	d	d	d	d	d	d	d	d	d
Word 1 -	e	p	0	0	0	0	0	1	0	0	0	0	d	d	d	d

Data Word
Command Word

Net Weight (read only)

Dec: 2 Hex: 2 Range: 0-±999999

Input Table

Dec. Bit -	15	14	13	12	11	10	9	8	7	6	5	4	3	2	1	0
Word 0 -	0	0	0	0	0	0	0	0	0	0	0	0	0	0	0	0
Word 1 -	0	0	0	0	0	0	1	0	0	0	0	0	0	0	0	0

Data Word
Command Word

Output Table

Dec. Bit -	15	14	13	12	11	10	9	8	7	6	5	4	3	2	1	0
Word 0 -	d	d	d	d	d	d	d	d	d	d	d	d	d	d	d	d
Word 1 -	e	p	0	0	0	0	1	0	0	0	0	0	d	d	d	d

Data Word
Command Word

Tare (set only)

Dec: 6 Hex: 6 Range: N/A

Input Table

Dec. Bit -	15	14	13	12	11	10	9	8	7	6	5	4	3	2	1	0
Word 0 -	0	0	0	0	0	0	0	0	0	0	0	0	0	0	0	1
Word 1 -	1	0	0	0	0	1	1	0	0	0	0	0	0	0	0	0

Data Word
Command Word

Output Table

Dec. Bit -	15	14	13	12	11	10	9	8	7	6	5	4	3	2	1	0
Word 0 -	0	0	0	0	0	0	0	0	0	0	0	0	0	0	0	0
Word 1 -	e	p	0	0	0	1	1	0	0	0	0	0	0	0	0	0

Data Word
Command Word

Note: To set tare, set bit 0 of Data Word to 1 and use the Write bit.

Control Mode Commands: MVS-Modbus/Weigh II

Status (read only)

Dec: 7 Hex: 7 Range: 0-255

Input Table

Dec. Bit -	15	14	13	12	11	10	9	8	7	6	5	4	3	2	1	0
Word 0 -	0	0	0	0	0	0	0	0	0	0	0	0	0	0	0	0
Word 1 -	0	0	0	0	0	1	1	1	0	0	0	0	0	0	0	0

Data Word
Command Word

Output Table

Dec. Bit -	15	14	13	12	11	10	9	8	7	6	5	4	3	2	1	0
Word 0 -	d	d	d	d	d	d	d	d	0	0	0	0	0	0	0	0
Word 1 -	e	p	0	0	0	1	1	1	0	0	0	0	0	0	0	0

Data Word
Command Word

Notes: Description of status (bits 8-15 of data word)

Bit 8 -Net units negative

Bit 9 - N/A

Bit 10 - During Auto Cal "Warning: Move More Material"

Bit 11 - During Auto Cal: "Ambiguous Error"

lo_cnt>hi_cnt. Other: Illegal average factor

Bit 12 - COM error condition

Bit 13 - Analog input overrange

Bit 14 - Engineering unit overflow

Bit 15 - Gross units negative

Zero Cal (Auto Calibration)

Dec: 8 Hex: 8 Range: 0-999999

Input Table

Dec. Bit -	15	14	13	12	11	10	9	8	7	6	5	4	3	2	1	0
Word 0 -	0	0	0	0	0	0	0	0	0	0	0	0	0	0	0	0
Word 1 -	0	0	0	0	1	0	0	0	0	0	0	0	0	0	0	0

Data Word
Command Word

Output Table

Dec. Bit -	15	14	13	12	11	10	9	8	7	6	5	4	3	2	1	0
Word 0 -	d	d	d	d	d	d	d	d	d	d	d	d	d	d	d	d
Word 1 -	e	p	0	0	1	0	0	0	0	0	0	0	d	d	d	d

Data Word
Command Word

Note: You must move material when performing Auto Cal. See *Weigh II Installation and Operation Manual*.

Lo Span Cal (Auto Calibration)

Dec: 9 Hex: 9 Range: 0-999999

Input Table

Dec. Bit -	15	14	13	12	11	10	9	8	7	6	5	4	3	2	1	0
Word 0 -	0	0	0	0	0	0	0	0	0	0	0	0	0	0	0	0
Word 1 -	0	0	0	0	1	0	0	1	0	0	0	0	0	0	0	0

Data Word
Command Word

Output Table

Dec. Bit -	15	14	13	12	11	10	9	8	7	6	5	4	3	2	1	0
Word 0 -	d	d	d	d	d	d	d	d	d	d	d	d	d	d	d	d
Word 1 -	e	p	0	0	1	0	0	1	0	0	0	0	d	d	d	d

Data Word
Command Word

Note: You must move material when performing Auto Cal. See *Weigh II Installation and Operation Manual*.

Legend: Dec = # in decimal form; Hex = # in hexadecimal form; e = error; p = polarity; ddd... = data; D... = subcommand

Control Mode Commands: MVS-Modbus/Weigh II

Hi Span Cal (Auto Calibration)

Dec: 10 Hex: A Range: 0-999999

Input Table

Dec. Bit -	15	14	13	12	11	10	9	8	7	6	5	4	3	2	1	0
Word 0 -	0	0	0	0	0	0	0	0	0	0	0	0	0	0	0	0
Word 1 -	0	0	0	0	1	0	1	0	0	0	0	0	0	0	0	0

Data Word
Command Word

Output Table

Dec. Bit -	15	14	13	12	11	10	9	8	7	6	5	4	3	2	1	0
Word 0 -	d	d	d	d	d	d	d	d	d	d	d	d	d	d	d	d
Word 1 -	e	p	0	0	1	0	1	0	0	0	0	0	d	d	d	d

Data Word
Command Word

Note: You must move material when performing Auto Cal. See *Weigh II Installation and Operation Manual*.

Scale Factor Counts (Manual Calibration)

Dec: 11 Hex: B Range: 0-2097151

Input Table

Dec. Bit -	15	14	13	12	11	10	9	8	7	6	5	4	3	2	1	0
Word 0 -	0	0	0	0	0	0	0	0	0	0	0	0	0	0	0	0
Word 1 -	0	0	0	0	1	0	1	1	0	0	0	0	0	0	0	0

Data Word
Command Word

Output Table

Dec. Bit -	15	14	13	12	11	10	9	8	7	6	5	4	3	2	1	0
Word 0 -	d	d	d	d	d	d	d	d	d	d	d	d	d	d	d	d
Word 1 -	e	p	0	0	1	0	1	1	0	0	0	d	d	d	d	d

Data Word
Command Word

Scale Factor Weight (Manual Calibration)

Dec: 12 Hex: C Range: 0-999999

Input Table

Dec. Bit -	15	14	13	12	11	10	9	8	7	6	5	4	3	2	1	0
Word 0 -	0	0	0	0	0	0	0	0	0	0	0	0	0	0	0	0
Word 1 -	0	0	0	0	1	1	0	0	0	0	0	0	0	0	0	0

Data Word
Command Word

Output Table

Dec. Bit -	15	14	13	12	11	10	9	8	7	6	5	4	3	2	1	0
Word 0 -	d	d	d	d	d	d	d	d	d	d	d	d	d	d	d	d
Word 1 -	e	p	0	0	1	1	0	0	0	0	0	0	d	d	d	d

Data Word
Command Word

Legend: Dec = # in decimal form; Hex =# in hexadecimal form; e = error; p = polarity; ddd... = data; D... = subcommand

Control Mode Commands: MVS-Modbus/Weigh II

Zero Counts (Manual Calibration)

Dec: 13 Hex: D Range: 0-2097151

Input Table

Dec. Bit -	15	14	13	12	11	10	9	8	7	6	5	4	3	2	1	0
Word 0 -	0	0	0	0	0	0	0	0	0	0	0	0	0	0	0	0
Word 1 -	0	0	0	0	1	1	0	1	0	0	0	0	0	0	0	0

Data Word
Command Word

Output Table

Dec. Bit -	15	14	13	12	11	10	9	8	7	6	5	4	3	2	1	0
Word 0 -	d	d	d	d	d	d	d	d	d	d	d	d	d	d	d	d
Word 1 -	e	p	0	0	1	1	0	1	0	0	0	d	d	d	d	d

Data Word
Command Word

Excitation

Dec: 14 Hex: E Range: 0-255

Input Table

Dec. Bit -	15	14	13	12	11	10	9	8	7	6	5	4	3	2	1	0
Word 0 -	0	0	0	0	0	0	0	0	0	0	0	0	0	0	0	0
Word 1 -	0	0	0	0	1	1	1	0	0	0	0	0	0	0	0	0

Data Word
Command Word

Output Table

Dec. Bit -	15	14	13	12	11	10	9	8	7	6	5	4	3	2	1	0
Word 0 -	0	0	0	0	0	0	0	0	d	d	d	d	d	d	d	d
Word 1 -	e	p	0	0	1	1	1	0	0	0	0	0	0	0	0	0

Data Word
Command Word

Averaging Factor

Dec: 16 Hex: 10 Range: 1-255

Input Table

Dec. Bit -	15	14	13	12	11	10	9	8	7	6	5	4	3	2	1	0
Word 0 -	0	0	0	0	0	0	0	0	0	0	0	0	0	0	0	0
Word 1 -	0	0	0	1	0	0	0	0	0	0	0	0	0	0	0	0

Data Word
Command Word

Output Table

Dec. Bit -	15	14	13	12	11	10	9	8	7	6	5	4	3	2	1	0
Word 0 -	0	0	0	0	0	0	0	0	d	d	d	d	d	d	d	d
Word 1 -	e	p	0	1	0	0	0	0	0	0	0	0	0	0	0	0

Data Word
Command Word

Legend: Dec = # in decimal form; Hex = # in hexadecimal form; e = error; p = polarity; ddd... = data; D... = subcommand

Control Mode Commands: MVS-Modbus/Weigh II

Raw Input Counts (Linearization Table)

Dec: 30 Hex: 1E Range: 0-2097151

Input Table

Dec. Bit -	15	14	13	12	11	10	9	8	7	6	5	4	3	2	1	0
Word 0 -	0	0	0	0	0	0	0	0	0	0	0	0	0	0	0	0
Word 1 -	0	0	0	1	1	1	1	0	D	D	D	0	0	0	0	0

Data Word
Command Word

Output Table

Dec. Bit -	15	14	13	12	11	10	9	8	7	6	5	4	3	2	1	0
Word 0 -	d	d	d	d	d	d	d	d	d	d	d	d	d	d	d	d
Word 1 -	e	p	0	1	1	1	1	0	0	0	0	d	d	d	d	d

Data Word
Command Word

Note: Bits 5, 6, & 7 of Command Word is Linear Table Entry Number (0=1st, 1=2nd, 2=3rd, 3=4th, 4=5th)

Corrected Output Counts (Linearization Table)

Dec: 31 Hex: 1F Range: 0-2097151

Input Table

Dec. Bit -	15	14	13	12	11	10	9	8	7	6	5	4	3	2	1	0
Word 0 -	0	0	0	0	0	0	0	0	0	0	0	0	0	0	0	0
Word 1 -	0	0	0	1	1	1	1	1	D	D	D	0	0	0	0	0

Data Word
Command Word

Output Table

Dec. Bit -	15	14	13	12	11	10	9	8	7	6	5	4	3	2	1	0
Word 0 -	d	d	d	d	d	d	d	d	d	d	d	d	d	d	d	d
Word 1 -	e	p	0	1	1	1	1	1	0	0	0	d	d	d	d	d

Data Word
Command Word

Note: Bits 5, 6, & 7 of Command Word is Linear Table Entry Number (0=1st, 1=2nd, 2=3rd, 3=4th, 4=5th)

Linearization Enable

Dec: 32 Hex: 20 Range: 0-1

Input Table

Dec. Bit -	15	14	13	12	11	10	9	8	7	6	5	4	3	2	1	0
Word 0 -	0	0	0	0	0	0	0	0	0	0	0	0	0	0	0	0
Word 1 -	0	0	1	0	0	0	0	0	0	0	0	0	0	0	0	0

Data Word
Command Word

Output Table

Dec. Bit -	15	14	13	12	11	10	9	8	7	6	5	4	3	2	1	0
Word 0 -	0	0	0	0	0	0	0	0	0	0	0	0	0	0	0	d
Word 1 -	e	p	1	0	0	0	0	0	0	0	0	0	0	0	0	0

Data Word
Command Word

Note: 0 = linearization off, 1 = linearization on

Legend: Dec = # in decimal form; Hex = # in hexadecimal form; e = error; p = polarity; ddd... = data; D... = subcommand

Control Mode Commands: MVS-Modbus/Weigh II

Raw A/D Counts (read only)

Dec: 33 Hex: 21 Range: 0-2097151

Input Table

Dec. Bit -	15	14	13	12	11	10	9	8	7	6	5	4	3	2	1	0
Word 0 -	0	0	0	0	0	0	0	0	0	0	0	0	0	0	0	0
Word 1 -	0	0	1	0	0	0	0	1	0	0	0	0	0	0	0	0

Data Word
Command Word

Output Table

Dec. Bit -	15	14	13	12	11	10	9	8	7	6	5	4	3	2	1	0
Word 0 -	d	d	d	d	d	d	d	d	d	d	d	d	d	d	d	d
Word 1 -	e	p	1	0	0	0	0	1	0	0	0	d	d	d	d	d

Data Word
Command Word

Application Type (read only)

Dec: 39 Hex: 27 Range: 0-99

Input Table

Dec. Bit -	15	14	13	12	11	10	9	8	7	6	5	4	3	2	1	0
Word 0 -	0	0	0	0	0	0	0	0	0	0	0	0	0	0	0	0
Word 1 -	0	0	1	0	0	1	1	1	0	0	0	0	0	0	0	0

Data Word
Command Word

Output Table

Dec. Bit -	15	14	13	12	11	10	9	8	7	6	5	4	3	2	1	0
Word 0 -	0	0	0	0	0	0	0	0	0	d	d	d	d	d	d	d
Word 1 -	e	p	1	0	0	1	1	1	0	0	0	0	0	0	0	0

Data Word
Command Word

Note: 0 = weight device, 99 = math channel

Chapter 12. Commands for MVS-Modbus/SVS 2000

Quick Command Reference Table for MVS-Modbus/SVS 2000

SVS 2000 Parameters	Command		Range	Comments	Page No.
	Dec	Hex			
Gross Weight	1	1	0-9999999	Value in selected engineering units	12-2
Net Weight	2	2	0-±9999999	Value in selected engineering units	12-2
Tare	6	6	—		12-2
Status (includes errors)	7	7	0-255		12-3
Display Value Correction (Auto)	8	8	0-999999	Value in selected engineering units	12-3
Lo Span Cal (Auto)	9	9	0-999999	Value in selected engineering units	12-3
Hi Span Cal (Auto)	10	A	0-999999	Value in selected engineering units	12-4
Scale Factor Counts (Manual)	11	B	0-2097151		12-4
Scale Factor Weight (Manual)	12	C	0-999999	Value in selected engineering units	12-4
Zero Counts (Manual)	13	D	0-2097151		12-5
Averaging	16	10	1-255		12-5
Linearize Set — Raw Input Weight ¹	30	1E	0-999999		12-5
Linearize Set — Corrected Output Weight ¹	31	1F	0-999999		12-6
Linearize Enable	32	20	0-1	0=linearization off, 1=linearization on	12-6
Raw A/D Counts	33	21	0-2097151		12-6
Filtered A/D Counts	35	23	0-2097151		12-7
Setpoint Preact ²	39	27	0-65535	Value in selected engineering units	12-7
Setpoint Value ^{2,3}	40	28	0-±999999	Value in selected engineering units	12-7
Setpoint Deadband ²	41	29	0-65535	Value in selected engineering units	12-8
Setpoint Hi/Lo ²	42	2A	0-1	0=Lo, 1=Hi	12-8
Setpoint Track ²	43	2B	0-3	0=Gross, 1=Net, 2=Total, 3=Fault	12-8
Setpoint Failsafe ²	44	2C	0-2	0=Off, 1=No Change, 2=On	12-9
Setpoint Force Mode ^{2,4}	45	2D	—		12-9
IOut Range	46	2E	0-1	0=0-20mA, 1=4-20mA	12-10
IOut 4/0mA Value ⁵	47	2F	0-±999999	Value in selected engineering units	12-10
IOut 20mA Value ⁵	48	30	0-±999999	Value in selected engineering units	12-10
IOut Track	49	31	0-1	0=Gross, 1=Net	12-11
IOut Failsafe	50	32	0-2	0=Lo, 1=Hi, 2=No Change	12-11
Current Force Mode ⁶	51	33	0-16383		12-11

Notes:

- Bits 5-7 of Command Word is linearization table entry number (0=1st entry through 4=5th entry).
- Bits 4-6 of Command Word is setpoint number (0=Relay1, 1=Relay2, 2=Digital Output1, through 7=Digital Output6).
- When Net is selected for Setpoint Track, Bit 7 of Command Word is polarity for Setpoint Value.
- To activate Setpoint Force Mode, set bit 1 of Data Word to 1 and set Write bit to 1. To deactivate Setpoint Force Mode, set bit 1 of Data Word to 0 and set Write bit to 1. Bit 0 of Data Word represents setpoint state (1=On, 0=Off) when Force Mode is active. When Force Mode is inactive, setpoint is controlled by SVS 2000.
- When Net is selected for IOut Track, Bit 7 of Command Word is polarity for 4/0 and 20 mA Values.
- To activate Current Force Mode, set bit 0 of Command Word to 1 and set Write bit to 1. To deactivate Current Force Mode, set bit 0 of Command Word to 0 and set Write bit to 1. Data in bits 0-13 of Data Word is value loaded into Current Output PCB of SVS 2000. When Force Mode is inactive, current output is controlled by SVS 2000.

CAUTION

The Setpoint and Current Force Mode commands remove control of the selected setpoint(s) and current output from the SVS 2000 and give control to the PLC. The SVS 2000 will not update the setpoint(s) or current output when the respective Force Mode is active.

Note

Refer to Chapter 4 for general information on PLC programming.

Control Mode Commands: MVS-Modbus/SVS 2000

Gross Weight (read only)

Dec: 1 Hex: 1 Range: 0-9999999

BTW Table

Dec. Bit -	15	14	13	12	11	10	9	8	7	6	5	4	3	2	1	0
Word 0 -	0	0	0	0	0	0	0	0	0	0	0	0	0	0	0	0
Word 1 -	0	0	0	0	0	0	0	1	0	0	0	0	0	0	0	0

Data Word
Command Word

BTR Table

Dec. Bit -	15	14	13	12	11	10	9	8	7	6	5	4	3	2	1	0
Word 0 -	d	d	d	d	d	d	d	d	d	d	d	d	d	d	d	d
Word 1 -	e	p	0	0	0	0	0	1	d	d	d	d	d	d	d	d

Data Word
Command Word

Net Weight (read only)

Dec: 2 Hex: 2 Range: 0-±9999999

BTW Table

Dec. Bit -	15	14	13	12	11	10	9	8	7	6	5	4	3	2	1	0
Word 0 -	0	0	0	0	0	0	0	0	0	0	0	0	0	0	0	0
Word 1 -	0	0	0	0	0	0	1	0	0	0	0	0	0	0	0	0

Data Word
Command Word

BTR Table

Dec. Bit -	15	14	13	12	11	10	9	8	7	6	5	4	3	2	1	0
Word 0 -	d	d	d	d	d	d	d	d	d	d	d	d	d	d	d	d
Word 1 -	e	p	0	0	0	0	1	0	d	d	d	d	d	d	d	d

Data Word
Command Word

Tare (set only)

Dec: 6 Hex: 6 Range: N/A

BTW Table

Dec. Bit -	15	14	13	12	11	10	9	8	7	6	5	4	3	2	1	0
Word 0 -	0	0	0	0	0	0	0	0	0	0	0	0	0	0	0	1
Word 1 -	1	0	0	0	0	1	1	0	0	0	0	0	0	0	0	0

Data Word
Command Word

BTR Table

Dec. Bit -	15	14	13	12	11	10	9	8	7	6	5	4	3	2	1	0
Word 0 -	0	0	0	0	0	0	0	0	0	0	0	0	0	0	0	0
Word 1 -	e	p	0	0	0	1	1	0	0	0	0	0	0	0	0	0

Data Word
Command Word

Note: To set tare, set bit 0 of Data Word to 1 and use the Write bit.

Control Mode Commands: MVS-Modbus/SVS 2000

Status (read only)

Dec: 7 Hex: 7 Range: 0-255

BTW Table

Dec. Bit -	15	14	13	12	11	10	9	8	7	6	5	4	3	2	1	0
Word 0 -	0	0	0	0	0	0	0	0	0	0	0	0	0	0	0	0
Word 1 -	0	0	0	0	0	1	1	1	0	0	0	0	0	0	0	0

Data Word
Command Word

BTR Table

Dec. Bit -	15	14	13	12	11	10	9	8	7	6	5	4	3	2	1	0
Word 0 -	d	d	d	d	d	d	d	d	0	0	0	0	0	0	0	0
Word 1 -	e	p	0	0	0	1	1	1	0	0	0	0	0	0	0	0

Data Word
Command Word

Notes: Description of status (bits 8-15 of data word)

Bit 8 -Net units negative

Bit 12 - N/A

Bit 9 - N/A

Bit 13 - Analog input overrange

Bit 10 - During Auto Cal "Warning: Move More Material"

Bit 14 - Engineering unit overflow

Bit 11 - During Auto Cal: "Ambiguous Error"

Bit 15 - Gross units negative

lo_cnt>hi_cnt. Other: Illegal average factor

Display Value Correction (Auto Calibration)

Dec: 8 Hex: 8 Range: 0-999999

BTW Table

Dec. Bit -	15	14	13	12	11	10	9	8	7	6	5	4	3	2	1	0
Word 0 -	0	0	0	0	0	0	0	0	0	0	0	0	0	0	0	0
Word 1 -	0	0	0	0	1	0	0	0	0	0	0	0	0	0	0	0

Data Word
Command Word

BTR Table

Dec. Bit -	15	14	13	12	11	10	9	8	7	6	5	4	3	2	1	0
Word 0 -	d	d	d	d	d	d	d	d	d	d	d	d	d	d	d	d
Word 1 -	e	p	0	0	1	0	0	0	0	0	0	0	d	d	d	d

Data Word
Command Word

Lo Span Cal (Auto Calibration)

Dec: 9 Hex: 9 Range: 0-999999

BTW Table

Dec. Bit -	15	14	13	12	11	10	9	8	7	6	5	4	3	2	1	0
Word 0 -	0	0	0	0	0	0	0	0	0	0	0	0	0	0	0	0
Word 1 -	0	0	0	0	1	0	0	1	0	0	0	0	0	0	0	0

Data Word
Command Word

BTR Table

Dec. Bit -	15	14	13	12	11	10	9	8	7	6	5	4	3	2	1	0
Word 0 -	d	d	d	d	d	d	d	d	d	d	d	d	d	d	d	d
Word 1 -	e	p	0	0	1	0	0	1	0	0	0	0	d	d	d	d

Data Word
Command Word

Note: You must move material when performing Auto Cal. See *SVS 2000 Installation and Operation Manual*.

Legend: Dec = # in decimal form; Hex = # in hexadecimal form; e = error; p = polarity; ddd... = data; D... = subcommand

Control Mode Commands: MVS-Modbus/SVS 2000

Hi Span Cal (Auto Calibration)

Dec: 10 Hex: A Range: 0-999999

BTW Table

Dec. Bit -	15	14	13	12	11	10	9	8	7	6	5	4	3	2	1	0
Word 0 -	0	0	0	0	0	0	0	0	0	0	0	0	0	0	0	0
Word 1 -	0	0	0	0	1	0	1	0	0	0	0	0	0	0	0	0

Data Word
Command Word

BTR Table

Dec. Bit -	15	14	13	12	11	10	9	8	7	6	5	4	3	2	1	0
Word 0 -	d	d	d	d	d	d	d	d	d	d	d	d	d	d	d	d
Word 1 -	e	p	0	0	1	0	1	0	0	0	0	0	d	d	d	d

Data Word
Command Word

Note: You must move material when performing Auto Cal. See SVS 2000 Installation and Operation Manual.

Scale Factor Counts (Manual Calibration)

Dec: 11 Hex: B Range: 0-2097151

BTW Table

Dec. Bit -	15	14	13	12	11	10	9	8	7	6	5	4	3	2	1	0
Word 0 -	0	0	0	0	0	0	0	0	0	0	0	0	0	0	0	0
Word 1 -	0	0	0	0	1	0	1	1	0	0	0	0	0	0	0	0

Data Word
Command Word

BTR Table

Dec. Bit -	15	14	13	12	11	10	9	8	7	6	5	4	3	2	1	0
Word 0 -	d	d	d	d	d	d	d	d	d	d	d	d	d	d	d	d
Word 1 -	e	p	0	0	1	0	1	1	0	0	0	d	d	d	d	d

Data Word
Command Word

Scale Factor Weight (Manual Calibration)

Dec: 12 Hex: C Range: 0-999999

BTW Table

Dec. Bit -	15	14	13	12	11	10	9	8	7	6	5	4	3	2	1	0
Word 0 -	0	0	0	0	0	0	0	0	0	0	0	0	0	0	0	0
Word 1 -	0	0	0	0	1	1	0	0	0	0	0	0	0	0	0	0

Data Word
Command Word

BTR Table

Dec. Bit -	15	14	13	12	11	10	9	8	7	6	5	4	3	2	1	0
Word 0 -	d	d	d	d	d	d	d	d	d	d	d	d	d	d	d	d
Word 1 -	e	p	0	0	1	1	0	0	0	0	0	0	d	d	d	d

Data Word
Command Word

Legend: Dec = # in decimal form; Hex =# in hexadecimal form; e = error; p = polarity; ddd... = data; D... = subcommand

Control Mode Commands: MVS-Modbus/SVS 2000

Zero Counts (Manual Calibration)

Dec: 13 Hex: D Range: 0-2097151

BTW Table

Dec. Bit -	15	14	13	12	11	10	9	8	7	6	5	4	3	2	1	0
Word 0 -	0	0	0	0	0	0	0	0	0	0	0	0	0	0	0	0
Word 1 -	0	0	0	0	1	1	0	1	0	0	0	0	0	0	0	0

Data Word
Command Word

BTR Table

Dec. Bit -	15	14	13	12	11	10	9	8	7	6	5	4	3	2	1	0
Word 0 -	d	d	d	d	d	d	d	d	d	d	d	d	d	d	d	d
Word 1 -	e	p	0	0	1	1	0	1	0	0	0	d	d	d	d	d

Data Word
Command Word

Averaging

Dec: 16 Hex: 10 Range: 1-255

BTW Table

Dec. Bit -	15	14	13	12	11	10	9	8	7	6	5	4	3	2	1	0
Word 0 -	0	0	0	0	0	0	0	0	0	0	0	0	0	0	0	0
Word 1 -	0	0	0	1	0	0	0	0	0	0	0	0	0	0	0	0

Data Word
Command Word

BTR Table

Dec. Bit -	15	14	13	12	11	10	9	8	7	6	5	4	3	2	1	0
Word 0 -	0	0	0	0	0	0	0	0	d	d	d	d	d	d	d	d
Word 1 -	e	p	0	1	0	0	0	0	0	0	0	0	0	0	0	0

Data Word
Command Word

Linearize Set — Raw Input Weight

Dec: 30 Hex: 1E Range: 0-999999

BTW Table

Dec. Bit -	15	14	13	12	11	10	9	8	7	6	5	4	3	2	1	0
Word 0 -	0	0	0	0	0	0	0	0	0	0	0	0	0	0	0	0
Word 1 -	0	0	0	1	1	1	1	0	D	D	D	0	0	0	0	0

Data Word
Command Word

BTR Table

Dec. Bit -	15	14	13	12	11	10	9	8	7	6	5	4	3	2	1	0
Word 0 -	d	d	d	d	d	d	d	d	d	d	d	d	d	d	d	d
Word 1 -	e	p	0	1	1	1	1	0	0	0	0	0	d	d	d	d

Data Word
Command Word

Note: Bits 5, 6, and 7 of Command Word is Linear Table Entry Number (0=1st through 4=5th)

Control Mode Commands: MVS-Modbus/SVS 2000

Linearize Set — Corrected Output Weight

Dec: 31 Hex: 1F Range: 0-999999

BTW Table

Dec. Bit -	15	14	13	12	11	10	9	8	7	6	5	4	3	2	1	0	
Word 0 -	0	0	0	0	0	0	0	0	0	0	0	0	0	0	0	0	Data Word
Word 1 -	0	0	0	1	1	1	1	1	D	D	D	0	0	0	0	0	Command Word

BTR Table

Dec. Bit -	15	14	13	12	11	10	9	8	7	6	5	4	3	2	1	0	
Word 0 -	d	d	d	d	d	d	d	d	d	d	d	d	d	d	d	d	Data Word
Word 1 -	e	p	0	1	1	1	1	1	0	0	0	0	d	d	d	d	Command Word

Note: Bits 5, 6, and 7 of Command Word is Linear Table Entry Number (0=1st through 4=5th)

Linearize Enable

Dec: 32 Hex: 20 Range: 0-1

BTW Table

Dec. Bit -	15	14	13	12	11	10	9	8	7	6	5	4	3	2	1	0	
Word 0 -	0	0	0	0	0	0	0	0	0	0	0	0	0	0	0	0	Data Word
Word 1 -	0	0	1	0	0	0	0	0	0	0	0	0	0	0	0	0	Command Word

BTR Table

Dec. Bit -	15	14	13	12	11	10	9	8	7	6	5	4	3	2	1	0	
Word 0 -	0	0	0	0	0	0	0	0	0	0	0	0	0	0	0	d	Data Word
Word 1 -	e	p	1	0	0	0	0	0	0	0	0	0	0	0	0	0	Command Word

Note: 0 = linearization off, 1 = linearization on

Raw A/D Counts (read only)

Dec: 33 Hex: 21 Range: 0-2097151

BTW Table

Dec. Bit -	15	14	13	12	11	10	9	8	7	6	5	4	3	2	1	0	
Word 0 -	0	0	0	0	0	0	0	0	0	0	0	0	0	0	0	0	Data Word
Word 1 -	0	0	1	0	0	0	0	1	0	0	0	0	0	0	0	0	Command Word

BTR Table

Dec. Bit -	15	14	13	12	11	10	9	8	7	6	5	4	3	2	1	0	
Word 0 -	d	d	d	d	d	d	d	d	d	d	d	d	d	d	d	d	Data Word
Word 1 -	e	p	1	0	0	0	0	1	0	0	0	d	d	d	d	d	Command Word

Legend: Dec = # in decimal form; Hex = # in hexadecimal form; e = error; p = polarity; ddd... = data; D... = subcommand

Control Mode Commands: MVS-Modbus/SVS 2000

Filtered A/D Counts (read only)

Dec: 35 Hex: 23 Range: 0-2097151

BTW Table

Dec. Bit -	15	14	13	12	11	10	9	8	7	6	5	4	3	2	1	0
Word 0 -	0	0	0	0	0	0	0	0	0	0	0	0	0	0	0	0
Word 1 -	0	0	1	0	0	0	1	1	0	0	0	0	0	0	0	0

Data Word
Command Word

BTR Table

Dec. Bit -	15	14	13	12	11	10	9	8	7	6	5	4	3	2	1	0
Word 0 -	d	d	d	d	d	d	d	d	d	d	d	d	d	d	d	d
Word 1 -	e	p	1	0	0	0	1	1	0	0	0	d	d	d	d	d

Data Word
Command Word

Setpoint Preact

Dec: 39 Hex: 27 Range: 0-65535

BTW Table

Dec. Bit -	15	14	13	12	11	10	9	8	7	6	5	4	3	2	1	0
Word 0 -	0	0	0	0	0	0	0	0	0	0	0	0	0	0	0	0
Word 1 -	0	0	1	0	0	1	1	1	0	D	D	D	0	0	0	0

Data Word
Command Word

BTR Table

Dec. Bit -	15	14	13	12	11	10	9	8	7	6	5	4	3	2	1	0
Word 0 -	d	d	d	d	d	d	d	d	d	d	d	d	d	d	d	d
Word 1 -	e	p	1	0	0	1	1	1	0	0	0	0	0	0	0	0

Data Word
Command Word

Note: Bits 4, 5, and 6 of Command Word is the setpoint number (0=Relay1, 1=Relay2, 2=Digital Output1, through 7=Digital Output6).

Setpoint Value

Dec: 40 Hex: 28 Range: 0-±999999

BTW Table

Dec. Bit -	15	14	13	12	11	10	9	8	7	6	5	4	3	2	1	0
Word 0 -	0	0	0	0	0	0	0	0	0	0	0	0	0	0	0	0
Word 1 -	0	0	1	0	1	0	0	0	0	D	D	D	0	0	0	0

Data Word
Command Word

BTR Table

Dec. Bit -	15	14	13	12	11	10	9	8	7	6	5	4	3	2	1	0
Word 0 -	d	d	d	d	d	d	d	d	d	d	d	d	d	d	d	d
Word 1 -	e	0	1	0	1	0	0	0	p	0	0	0	d	d	d	d

Data Word
Command Word

Notes:

- Bits 4, 5, and 6 of Command Word is the setpoint number (0=Relay1, 1=Relay2, 2=Digital Output1, through 7=Digital Output6).
- When Net is selected for Setpoint Track, Bit 7 of Command Word is polarity for the Setpoint Value.

Legend: Dec = # in decimal form; Hex = # in hexadecimal form; e = error; p = polarity; ddd... = data; D... = subcommand

Control Mode Commands: MVS-Modbus/SVS 2000

Setpoint Deadband

Dec: 41 Hex: 29 Range: 0-65535

BTW Table

Dec. Bit -	15	14	13	12	11	10	9	8	7	6	5	4	3	2	1	0
Word 0 -	0	0	0	0	0	0	0	0	0	0	0	0	0	0	0	0
Word 1 -	0	0	1	0	1	0	0	1	0	D	D	D	0	0	0	0

Data Word
Command Word

BTR Table

Dec. Bit -	15	14	13	12	11	10	9	8	7	6	5	4	3	2	1	0
Word 0 -	d	d	d	d	d	d	d	d	d	d	d	d	d	d	d	d
Word 1 -	e	p	1	0	1	0	0	1	0	0	0	0	0	0	0	0

Data Word
Command Word

Note: Bits 4, 5, and 6 of Command Word is the setpoint number (0=Relay1, 1=Relay2, 2=Digital Output1, through 7=Digital Output6).

Setpoint Hi/Lo

Dec: 42 Hex: 2A Range: 0-1

BTW Table

Dec. Bit -	15	14	13	12	11	10	9	8	7	6	5	4	3	2	1	0
Word 0 -	0	0	0	0	0	0	0	0	0	0	0	0	0	0	0	0
Word 1 -	0	0	1	0	1	0	1	0	0	D	D	D	0	0	0	0

Data Word
Command Word

BTR Table

Dec. Bit -	15	14	13	12	11	10	9	8	7	6	5	4	3	2	1	0
Word 0 -	0	0	0	0	0	0	0	0	0	0	0	0	0	0	0	d
Word 1 -	e	p	1	0	1	0	1	0	0	0	0	0	0	0	0	0

Data Word
Command Word

Notes:

- Bits 4, 5, and 6 of Command Word is the setpoint number (0=Relay1, 1=Relay2, 2=Digital Output1, through 7=Digital Output6).
- Bit 0 of Data Word: 0=Lo, 1=Hi

Setpoint Track

Dec: 43 Hex: 2B Range: 0-3

BTW Table

Dec. Bit -	15	14	13	12	11	10	9	8	7	6	5	4	3	2	1	0
Word 0 -	0	0	0	0	0	0	0	0	0	0	0	0	0	0	0	0
Word 1 -	0	0	1	0	1	0	1	1	0	D	D	D	0	0	0	0

Data Word
Command Word

BTR Table

Dec. Bit -	15	14	13	12	11	10	9	8	7	6	5	4	3	2	1	0
Word 0 -	0	0	0	0	0	0	0	0	0	0	0	0	0	0	d	d
Word 1 -	e	p	1	0	1	0	1	1	0	0	0	0	0	0	0	0

Data Word
Command Word

Notes:

- Bits 4, 5, and 6 of Command Word is the setpoint number (0=Relay1, 1=Relay2, 2=Digital Output1, through 7=Digital Output6).
- Bit 0 and 1 of Data Word: 0=Gross, 1=Net, 2=Total, 3=Fault

Legend: Dec = # in decimal form; Hex = # in hexadecimal form; e = error; p = polarity; ddd... = data; D... = subcommand

Control Mode Commands: MVS-Modbus/SVS 2000

Setpoint Failsafe

Dec: 44 Hex: 2C Range: 0-2

BTW Table

Dec. Bit -	15	14	13	12	11	10	9	8	7	6	5	4	3	2	1	0	
Word 0 -	0	0	0	0	0	0	0	0	0	0	0	0	0	0	0	0	Data Word
Word 1 -	0	0	1	0	1	1	0	0	0	D	D	D	0	0	0	0	Command Word

BTR Table

Dec. Bit -	15	14	13	12	11	10	9	8	7	6	5	4	3	2	1	0	
Word 0 -	0	0	0	0	0	0	0	0	0	0	0	0	0	0	d	d	Data Word
Word 1 -	e	p	1	0	1	1	0	0	0	0	0	0	0	0	0	0	Command Word

Notes:

- Bits 4, 5, and 6 of Command Word is the setpoint number (0=Relay1, 1=Relay2, 2=Digital Output1, through 7=Digital Output6).
- Bits 0 and 1 of Data Word: 0=Off, 1=No Change, 2=On

Setpoint Force Mode (set only)

Dec: 45 Hex: 2D Range: N/A

BTW Table

Dec. Bit -	15	14	13	12	11	10	9	8	7	6	5	4	3	2	1	0	
Word 0 -	0	0	0	0	0	0	0	0	0	0	0	0	0	0	1	d	Data Word
Word 1 -	1	0	1	0	1	1	0	1	0	D	D	D	0	0	0	0	Command Word

BTR Table

Dec. Bit -	15	14	13	12	11	10	9	8	7	6	5	4	3	2	1	0	
Word 0 -	0	0	0	0	0	0	0	0	0	0	0	0	0	0	0	0	Data Word
Word 1 -	0	0	1	0	1	1	0	1	0	0	0	0	0	0	0	0	Command Word

Notes:

- Bits 4, 5, and 6 of Command Word is setpoint number (0=Relay1, 1=Relay2, 2=Digital Output1, through 7=Digital Output6).
- To activate Force Mode, set bit 1 of Data Word to 1 and set Write bit (bit 15 of Command Word) to 1. To deactivate Force Mode, set bit 1 of Data Word to 0 and set Write bit to 1.
- Bit 0 of Data Word represents state of setpoint (1=On, 0=Off) when Force Mode active. When Force Mode inactive, setpoint controlled by SVS 2000.

CAUTION

Setpoint Force Mode command removes control of setpoint from the SVS 2000 and gives it to the PLC. SVS 2000 will not update setpoint when Force Mode is active.

Control Mode Commands: MVS-Modbus/SVS 2000

IOut Range

Dec: 46 Hex: 2E Range: 0-1

BTW Table

Dec. Bit -	15	14	13	12	11	10	9	8	7	6	5	4	3	2	1	0
Word 0 -	0	0	0	0	0	0	0	0	0	0	0	0	0	0	0	0
Word 1 -	0	0	1	0	1	1	1	0	0	0	0	0	0	0	0	0

Data Word
Command Word

BTR Table

Dec. Bit -	15	14	13	12	11	10	9	8	7	6	5	4	3	2	1	0
Word 0 -	0	0	0	0	0	0	0	0	0	0	0	0	0	0	0	d
Word 1 -	e	p	1	0	1	1	1	0	0	0	0	0	0	0	0	0

Data Word
Command Word

Note: Bit 0 of Data Word: 0=0-20 mA, 1=4-20 mA

IOut 4/0 mA Value

Dec: 47 Hex: 2F Range: 0-±999999

BTW Table

Dec. Bit -	15	14	13	12	11	10	9	8	7	6	5	4	3	2	1	0
Word 0 -	0	0	0	0	0	0	0	0	0	0	0	0	0	0	0	0
Word 1 -	0	0	1	0	1	1	1	1	0	0	0	0	0	0	0	0

Data Word
Command Word

BTR Table

Dec. Bit -	15	14	13	12	11	10	9	8	7	6	5	4	3	2	1	0
Word 0 -	d	d	d	d	d	d	d	d	d	d	d	d	d	d	d	d
Word 1 -	e	0	1	0	1	1	1	1	p	0	0	0	d	d	d	d

Data Word
Command Word

Note: When Net is selected for IOut Track, Bit 7 of Command Word is polarity of 4/0 mA value.

IOut 20 mA Value

Dec: 48 Hex: 30 Range: 0-±999999

BTW Table

Dec. Bit -	15	14	13	12	11	10	9	8	7	6	5	4	3	2	1	0
Word 0 -	0	0	0	0	0	0	0	0	0	0	0	0	0	0	0	0
Word 1 -	0	0	1	1	0	0	0	0	0	0	0	0	0	0	0	0

Data Word
Command Word

BTR Table

Dec. Bit -	15	14	13	12	11	10	9	8	7	6	5	4	3	2	1	0
Word 0 -	d	d	d	d	d	d	d	d	d	d	d	d	d	d	d	d
Word 1 -	e	0	1	1	0	0	0	0	p	0	0	0	d	d	d	d

Data Word
Command Word

Note: When Net is selected for IOut Track, Bit 7 of Command Word is polarity of 20 mA value.

Legend: Dec = # in decimal form; Hex = # in hexadecimal form; e = error; p = polarity; ddd... = data; D... = subcommand

Control Mode Commands: MVS-Modbus/SVS 2000

IOut Track

Dec: 49 Hex: 31 Range: 0-1

		BTW Table																
Dec. Bit -		15	14	13	12	11	10	9	8	7	6	5	4	3	2	1	0	
Word 0 -		0	0	0	0	0	0	0	0	0	0	0	0	0	0	0	0	Data Word
Word 1 -		0	0	1	1	0	0	0	1	0	0	0	0	0	0	0	0	Command Word

		BTR Table																
Dec. Bit -		15	14	13	12	11	10	9	8	7	6	5	4	3	2	1	0	
Word 0 -		0	0	0	0	0	0	0	0	0	0	0	0	0	0	0	d	Data Word
Word 1 -		e	p	1	1	0	0	0	1	0	0	0	0	0	0	0	0	Command Word

Note: Bit 0 of Data Word: 0=Gross, 1=Net

IOut Failsafe

Dec: 50 Hex: 32 Range: 0-2

		BTW Table																
Dec. Bit -		15	14	13	12	11	10	9	8	7	6	5	4	3	2	1	0	
Word 0 -		0	0	0	0	0	0	0	0	0	0	0	0	0	0	0	0	Data Word
Word 1 -		0	0	1	1	0	0	1	0	0	0	0	0	0	0	0	0	Command Word

		BTR Table																
Dec. Bit -		15	14	13	12	11	10	9	8	7	6	5	4	3	2	1	0	
Word 0 -		0	0	0	0	0	0	0	0	0	0	0	0	0	0	d	d	Data Word
Word 1 -		e	p	1	1	0	0	1	0	0	0	0	0	0	0	0	0	Command Word

Note: Bits 0 and 1 of Data Word: 0=Lo, 1=Hi, 2=No Change

Current Force Mode (set only)

Dec: 51 Hex: 33 Range: 0-16383

		BTW Table																
Dec. Bit -		15	14	13	12	11	10	9	8	7	6	5	4	3	2	1	0	
Word 0 -		0	0	d	d	d	d	d	d	d	d	d	d	d	d	d	d	Data Word
Word 1 -		1	0	1	1	0	0	1	1	0	0	0	0	0	0	0	1	Command Word

		BTR Table																
Dec. Bit -		15	14	13	12	11	10	9	8	7	6	5	4	3	2	1	0	
Word 0 -		0	0	0	0	0	0	0	0	0	0	0	0	0	0	0	0	Data Word
Word 1 -		0	0	1	1	0	0	1	1	0	0	0	0	0	0	0	0	Command Word

Notes:

- To activate Force Mode, set bit 0 of Command Word to 1 and set Write bit (bit 15) to 1.
To deactivate Force Mode, set bit 0 of Command Word to 0 and set Write bit to 1.
- Data in bits 0-13 of Data Word is value loaded into Current Output PCB of SVS 2000. 0 is associated with 0/4 mA (dependent on what was selected for IOut Range) and 16383 is associated with 20 mA. A-B RIO does a linear interpolation between those two currents to calculate value of the forced current.
- When Force Mode inactive (bit 0 of Command Word set to 0), current output is controlled by SVS 2000.

CAUTION

Current Force Mode command removes control of current output from the SVS 2000 and gives it to the PLC. SVS 2000 will not update current output when Force Mode is active.

Legend: Dec = # in decimal form; Hex = # in hexadecimal form; e = error; p = polarity; ddd... = data; D... = subcommand

Appendix A. Kistler-Morse Service and Warranty

Product Warranty

A complete, unabridged copy of our product warranty is available upon request from Kistler-Morse. A summary of the warranty, *subject to the terms and conditions listed fully in the warranty*, follows:

Kistler-Morse warrants equipment of its own manufacture to be free from defects in material and workmanship for one year from date of shipment to original user. Kistler-Morse will replace or repair, at our option, any part found to be defective. Buyer must return any part claimed defective to Kistler-Morse, transportation prepaid.

Service

K-M maintains a fully trained staff of field service personnel who are capable of providing you with complete product assistance. Our field service staff is based in Bothell, Washington USA (corporate headquarters) and Antwerp, Belgium (European office).

Phone Consultation

Our Field Service staff provides the following services by telephone, via our regular and toll free number (toll free in USA and Canada only):

- Technical, application, and troubleshooting assistance
- Spare parts assistance
- Warranty (replacement) assistance

On-Site Consultation

K-M's Field Service staff can provide additional services at your request. Contact K-M at the closest office for rate and scheduling information for the following services:

- Technical, application, startup, and troubleshooting assistance on-site
- Training on-site or at our corporate office
- Service calls
- Equipment updates to our latest configuration

General descriptions of some of these standard services follow. Of course, if your service needs vary from those described, we are available to discuss them with you.

Installation, Startup Assistance, and On-Site Training

Notes

1. For vessels to be instrumented with Microcells™, L-Cells®, or Sonocells, the customer may contract to have K-M install the sensors/transducers. For all other types of sensors and transducers, installation must be performed by the customer.
 2. Field wiring, conduit installation, junction box mounting, and signal processor mounting must be performed by the customer. The AC power must be connected to the signal processor, but not energized, prior to K-M beginning work.
-

All field wiring will be checked for errors. The system will be powered up and checked for proper electrical operation. For best results, K-M requires moving a known amount of material, such as a truckload, for Live Load calibration. Live load calibration will be performed if actual material or weight devices can be moved. If it is not possible to move material, a Manual calibration will be performed. Recommendations for the optimal performance of the system will be provided.

On-site training will include simulation of the Live Load calibration process (if Live Load calibration could not be performed while K-M is on site) and instruction covering operation and maintenance of the system.

Troubleshooting

K-M will troubleshoot systems for mechanical, electrical, calibration, and wiring errors. Normal component repairs will be made and wiring errors will be corrected, including replacement of non-repairable printed circuit boards.

Service Calls

K-M will perform on-site repair/replacement services.

Return Material Authorization

If a part needs to be sent to the factory for repair, contact K-M's corporate office and ask for a Return Material Authorization (RMA) number. The RMA number identifies the part and its owner and must be included with the part when it is shipped to the factory.

Address and Telephone Numbers

Corporate Office

Kistler-Morse Corporation
19021 120th Avenue NE
Bothell, WA 98011-9511 USA

Phone: 425-486-6600
Toll Free (U.S.A. and Canada): 800-426-9010
Fax: 425-402-1500
www.kistlermorse.com

European Office

Kistler-Morse Corporation
Rucaplein 531
B2610 Antwerp, Belgium

Phone: 32.3.218.99.99
Fax: 32.3.230.78.76

Appendix B. Technical Drawings

This appendix contains the following technical drawings for the MVS-Modbus:

Drawing No.	Drawing Title
TI-MP.MVSC-02	MVS Connections — Modbus RTU Slave Interface Card

**MODBUS RTU SERIAL TERMINATION BOARD
RS-232C**

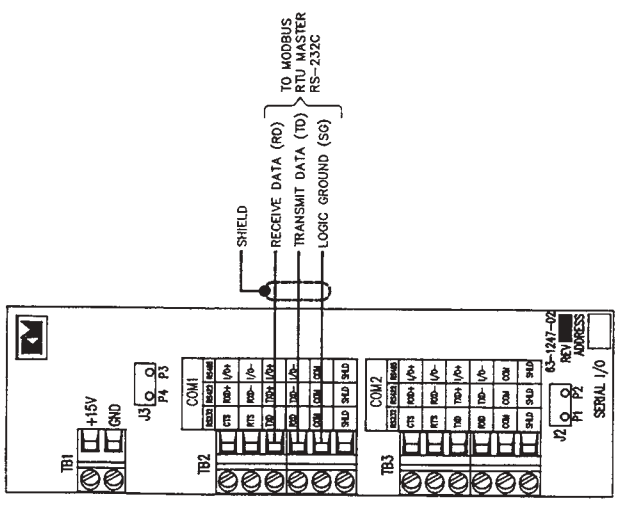

**MODBUS RTU SERIAL TERMINATION BOARD
RS-422A**

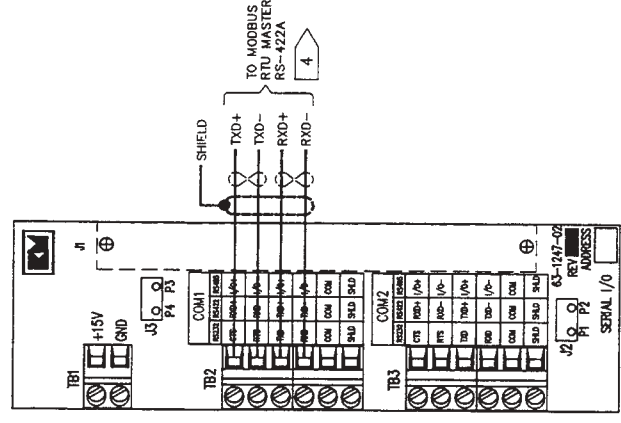

**MODBUS SERIAL TERMINATION BOARD
RS-485**

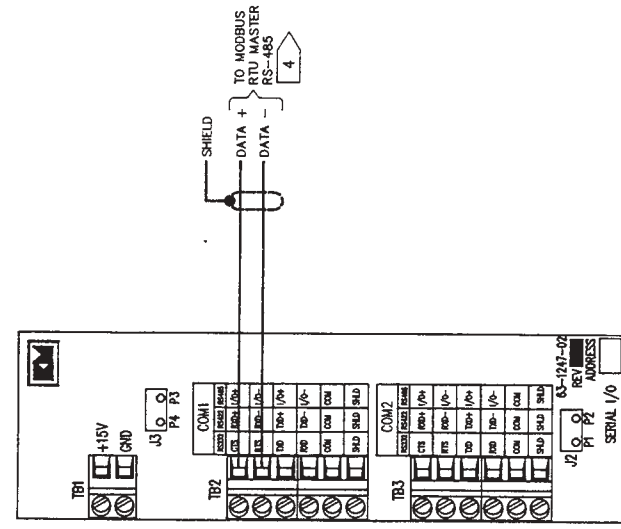

SIZE	DWG. NO.	REV.
B	T1-MP.MVSC-02	NEW
APP'D	DATE	REV. 2 OF 2
MPVSC2B	08/14/02	
APP: NONE		

