

Mark V Target
Strain Gage Flowmeter

**Installation, Operation
and Maintenance Manual**

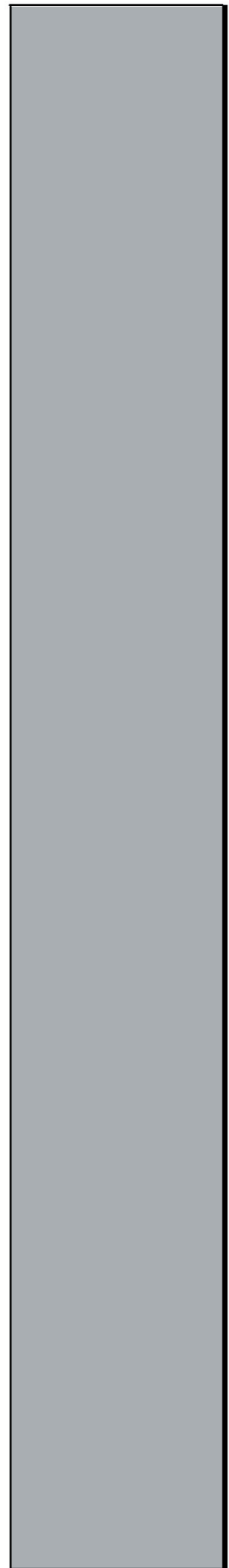

Table of Contents

Installation	
General	2
Retractable	3
Preparation of Pipeline for Probe Style Meters	5
Operation	6
Electrical Calibration	7
General Notes	7
Theory	8
Dimensions	
In-line	10
Probe	11
Model/Part Numbers	12
General Information	
Field Checking of Calibration Accuracy	13
Viscosity and the Target Flowmeter	15
Correction Factors for Gas	16
Correction Factors for Steam	17
Corrections for Change in Flow Meter Sensitivity	17
Removal/Replacement of Sensing Element for:	
In-line Meters	19
Probe Meters	20

Installation, Operation & Maintenance

GENERAL

The Mark V Flowmeter is an extremely accurate and sensitive liquid, steam, or gas flow measuring device. The dynamic force of fluid flow, or velocity head of the approaching stream, is sensed as a drag force on a target (disc) suspended in the flow stream. This force is transmitted via a lever rod and flexure tube to an externally bonded, four active arm strain gage bridge (see Figure 1, page 2). This strain gage bridge circuit translates the mechanical stress due to the sensor (target) drag into a directly proportional electrical output. Translation is linear. The drag force itself is usually proportional to the flow rate squared (see Figure 2, page 2). The electrical output is virtually unaffected by variations in fluid temperature or static pressure head within the stated limitations of the unit.

The freedom from delicate bearings, linkages, and moving parts in the Mark V results in an accurate, rugged, and maintenance-free instrument. The Mark V is capable of fluid flow measurements under conditions impossible with other types of flowmeters.

Installation and operating costs are usually lower than with other types of flowmeters. Installation can usually be handled by one man using common tools. Maintenance is reduced since there are no adjustments in the flowmeter, and it has a long service life. Pumping costs for a pumped system may be significantly lower as a result of the substantially reduced pressure drop with increasing line size (see specification sheet S711 for pressure drop values).

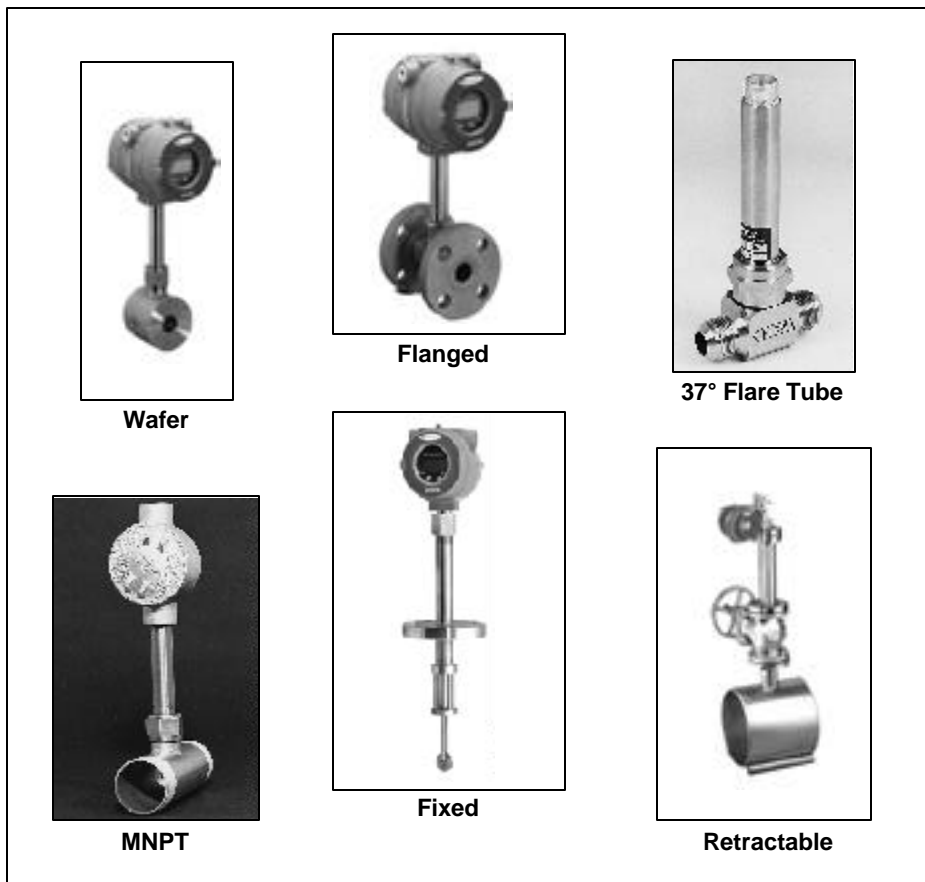

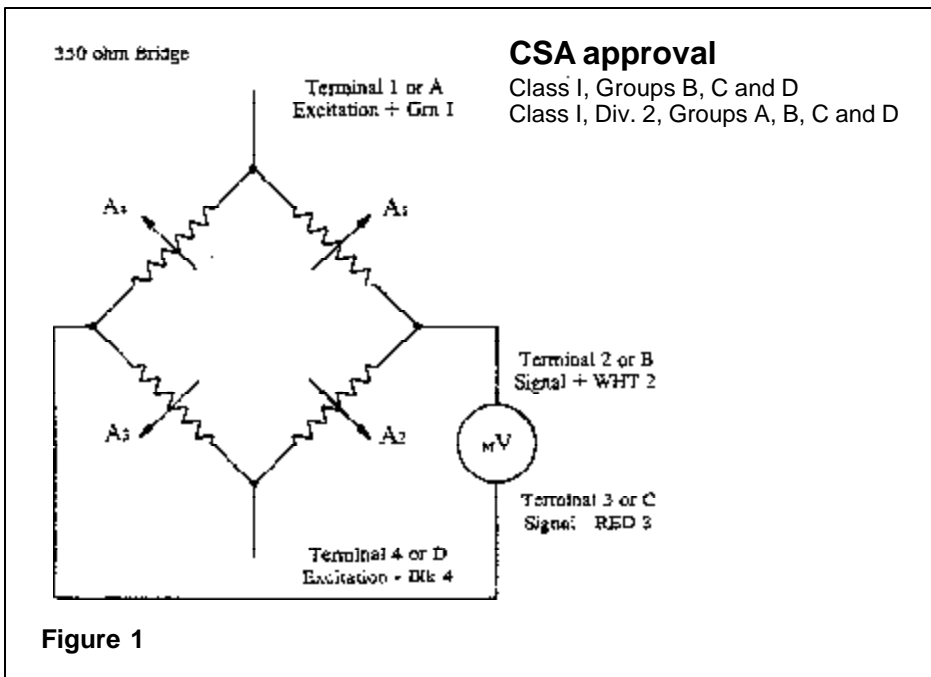

Figure 1

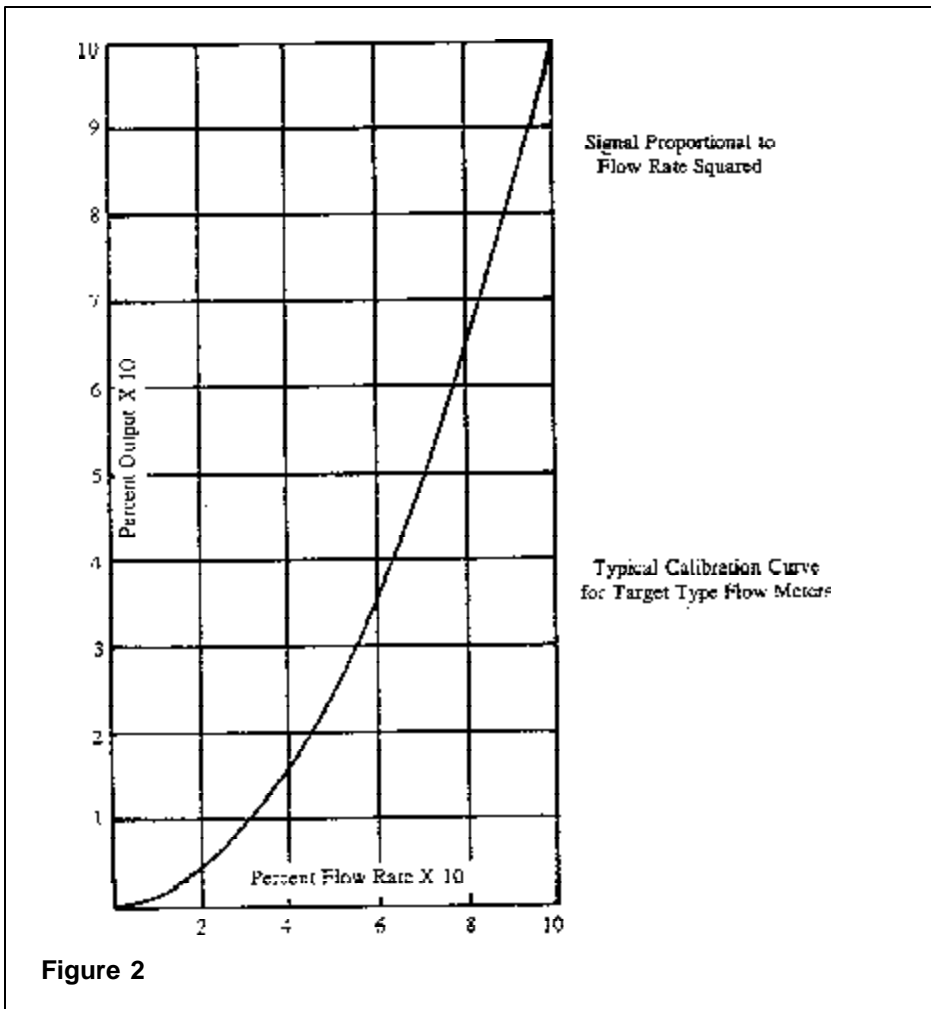

Figure 2

INSTALLATION

GENERAL

Care should be exercised in removing the flowmeter from its packing crate or carton and in installing it in the line. Do not damage sealing surfaces such as flange gasket surfaces and pipe threads. Avoid lifting the flowmeter by the target (disc) or target lever rod. Avoid damaging the target.

The Mark V should be installed on the upstream side of any flow controls or shut off valves to insure complete immersion of the target in the fluid at all rates of flow.

The small tube meters must be preceded by at least ten diameters of straight, uninterrupted flow line and followed by a minimum of five diameters. Do not precede the instrument with flexible corrugated tubing. Pipe, wafer or probe types should be preceded by a minimum of twenty diameters and followed by a minimum of ten diameters of straight uninterrupted flow line. "Pipe diameters" is the straight length of pipe divided by the nominal pipe size.

Probe style meters are installed in the line through a customer fabricated flanged stub. See fabrication details on page 5.

The Mark V may be mounted in any position, but care must be taken to keep the electrical connections clean and moisture free. It is advisable to inform Aaliant of the chosen mounting position when placing the order.

For dc excited systems, the electrical cable should be a four or six conductor shielded cable, jacketed with rubber, neoprene, vinyl or similar material. Wire gauge should be chosen taking lead wire loop resistance into consideration. For example, in a 350 ohm bridge, the error will not exceed 1/2% with up to 45 feet of #22 gauge cable, 75 feet of 20 gauge, 135 feet of 18 gauge, or 210 feet of 16 gauge.*

Electrical Connections Terminals

A or 1 — Bridge Excitation + Green

D or 4 — Bridge Excitation + Black

B or 2 — Bridge Output - White

C or 3 — Bridge Output - Red

E or 5 — Case Ground

Protect all connections with a silicone moisture proof compound.*

*If the flowmeter is supplied with an Aaliant transmitter, see separate instructions for recommended wiring and electrical connections.

RETRACTABLE TARGET FLOWMETER

Unpacking – See General

Do not turn the hand wheel, any knobs, or the lock bolts until instructed to do so. Read any tags and observe the precautions printed on them.

Preparation of the Pipeline

The flowmeter must be preceded by at least twenty diameters of straight uninterrupted flow line and followed by a minimum of ten diameters. Ideally, the total length of straight pipe should be broken only where the flowmeter is inserted. Exceptions are full bore ball valves, small dead-end (no flow) pressure taps and thermowells. Steam traps should be located just ahead of and just beyond the straight run. If a bidirectional flow measuring unit has been ordered, the flowmeter should have 20 diameters of straight pipe on each side of the flowmeter unless the reverse flow accuracy is less important. Consult Aaliant.

The use of steam traps, while at the option of the user, is strongly recommended in saturated steam systems. The use of the traps minimizes the accumulation of condensate in the bottom of the pipe. This accumulation changes the effective cross-sectional area of the pipe, introducing an error in the indicated flow rate. This error affects all head-class flowmeters.

A flanged stub is required on the pipeline. Dimensional drawings of the stub and orientation of the flange bolt holes are on pages 5 and 6. The inside configuration of the stub must be as shown on the drawings to permit the target to be inserted and withdrawn without interference. A gate valve or full bore ball valve will be mounted to the stub flange, and the flowmeter will be mounted to the valve. The retraction mechanism on the flowmeter permits the sensing portion of the flowmeter (the target) to be inserted or retracted while there is flow in the line. After retraction, the valve can be closed permitting removal of the flowmeter without shutting down the pipeline.

For existing installations, it is possible to make a hot tap into a pipeline without shutting down the flow. After the cutting tool has been removed from the stub and valve, the flowmeter can be installed.

The flowmeter may be mounted in any position. The preferred position is with the pipe horizontal and the flowmeter vertical. This arrangement makes it easier for the installer to position the flowmeter and align the gaskets. It is advisable for the customer to inform Aaliant of the chosen mounting position when placing the order.

Integral pressure and temperature sensors, if they are included, do not affect the piping requirements.

Mounting the Flowmeter

Refer to the flowmeter outline drawing for location of the various flowmeter parts. Locate the lock bolt and hand wheel. Do not remove the lock bolt nor turn the hand wheel until instructed.

The target is a disc that has been accurately sized for the flow rate. Locate the target. The flowmeter is shipped with the target retracted within the lower housing assembly. This protects it as the flowmeter is being installed. In some installations the temperature sensor is in a small, sealed tube adjacent to the target. Both the target and the temperature sensor must not be handled roughly.

After the valve has been properly assembled to the line, assemble the flowmeter and a gasket to the valve. The flow arrow must be pointing in the direction of flow. On bidirectional systems, the arrow indicates forward flow.

The target and its support will have to move into and out of the line freely. All of the parts through which the target passes should be in alignment with the stub flange. This includes the valve, the gaskets on both sides of the valve and flowmeter. This is particularly important if the flowmeter is mounted horizontally. Use four wooden dowels in the bolt holes to align the parts. The dowel diameter should be $3/32$ " greater than that of the bolts. Replace the dowels with the bolts, one at a time.

When the bolts have been properly tightened, open the valve. **Do not remove the lock bolt nor turn the hand wheel until the valve is completely open.** Remove the lock bolt. Turn the hand wheel until the target is inserted to the correct depth as indicated by the holes in the guide block and locking bar being in alignment. Put the lock bolt in place and tighten. **Do not close the valve unless the target is completely withdrawn.**

It is recommended that, after the flowmeter is inserted, a chain be threaded through the valve and flowmeter hand wheels. The chain should be locked and a tag applied stating, "Retract flowmeter before closing valve."

Mark V Target Strain Gage Flowmeter

In some applications, the flowmeter will be moved from one line to another. If the lines are different diameters, then there will be more than one lock bolt hole. Put the guide block in the correct position for the line size marked, then put the lock bolt in place and tighten.

For background information on fluid flow, please read the section on Theory (page 8).

Electrical Connections

The flowmeter outline drawing shows the location of the junction box. Remove the cover to make electrical connections.

The junction box on the flowmeter moves up and down as the flowmeter is inserted and retracted. A flexible cable, armored if desired, should be installed between the junction box and a fixed junction box. An alternate is to use a flexible conduit and a continuous, unspliced cable.

Be sure that the cable and conduit locations allow access to the hand wheel and clearance for movement of the cable.

It is recommended that a sealing wye be used at the junction box on the flowmeter or at the nearest fixed junction box.

PREPARATION OF THE PIPELINE FOR PROBE METERS

A flanged stub must be fabricated on the pipeline. Either a 2" or 4" ANSI flange is required (refer to the meter model number on the data sheet for the flange size and rating). The appropriate drawing (Figures 3 and 4 on pages 5 and 6) gives the dimensions of the stub and orientation of the flange bolt holes. The inside configuration of this stub must be as shown on the drawing to permit the target to be inserted and withdrawn without interference. To guarantee target alignment, be sure the flange bolt holes straddle the pipe centerline.

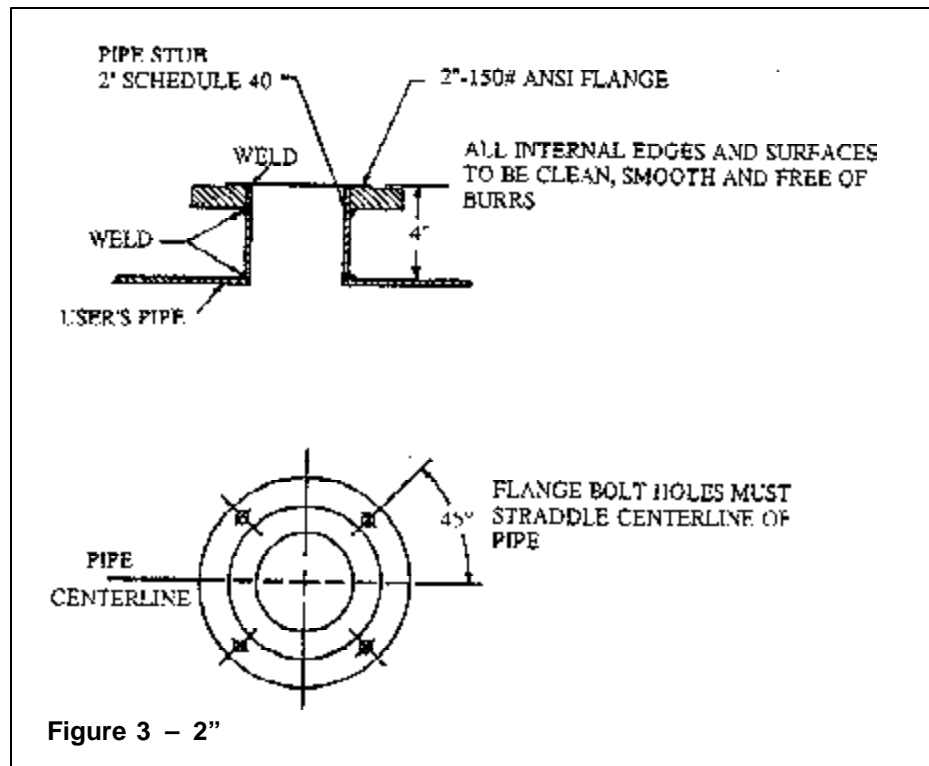

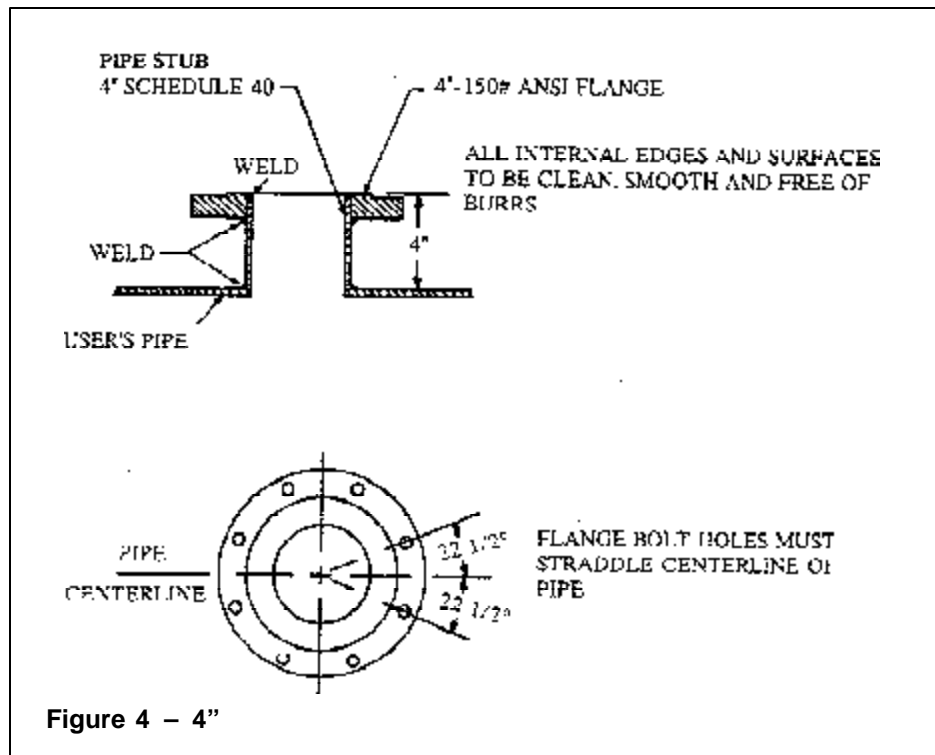

OPERATION

Consult data sheet to determine that the operating conditions of your installation do not exceed the limitations of pressure, temperature, etc., as set forth in the instrument.

The flow range of the flowmeter is usually given on the data sheet. The signal is continuous over the entire range from full scale to zero flow. However, to use the signal below 10% of flow, the associated electronic equipment must have an ultra-stable excitation voltage and a high gain, stable amplifier.

The flow rate at any point can be determined from the output signal at that point and the full range output (consult data sheet) from this equation:

$$Q_I = \sqrt{\frac{E_I}{E_{FS}}} Q_{FS}$$

where Q_I = Instantaneous flow rate
 Q_{FS} = Full scale flow rate
 E_I = Instantaneous voltage output
 E_{FS} = Full scale voltage output

Note: E_I and E_{FS} can be replaced by E_{rI} and E_{rFS} , the instantaneous and full scale outputs expressed in millivolts per volt of excitation.

The above equation is valid whenever the pipe Reynolds Number, R_D , indicates that flow is turbulent (see "Theory"). Determine that the excitation voltage does not exceed the maximum voltage stated. The Strain Gage elements of the flowmeter may be permanently damaged or burned out by overloads. It is a good precaution to measure the voltage level (if any) between either side of the bridge excitation supply and the piping ground before

Mark V Target Strain Gage Flowmeter

connecting the flowmeter. Any voltage indicates incomplete isolation of the excitation source and should be remedied, otherwise a voltage breakdown of the Strain Gage may occur.

For maximum stability and accuracy, allow at least 15 minutes of system warm-up time. In general, the lower the excitation voltage, the less flowmeter warm-up time required. For the utmost in stability, the excitation voltage must be constant and as low a value practical for your measuring equipment. Most commercial Strain Gage systems operate with a carrier or excitation voltage of between 3 and 10 volts.

ELECTRICAL CALIBRATION

(Not applicable if the flowmeter is supplied with a Hersey transmitter.) The factory calibration data may be coordinated with the user's equipment electrically, by the following method. If a precision resistor (decade box, etc.) is shunted between terminals A and B (or 1 and 2) of the flowmeter, an electrical unbalance signal (in millivolts/volt of excitation) will be obtained. This must, of course, be accomplished with the electrical system at zero balance (no flow conditions). This calibrating resistor may be permanently connected into the system through a normally open switch. Thus, standardization of system gain or drift may be checked at any time by merely stopping flow, pressing the switch, and noting the amplitude on the recorder or indicator resulting from the simulated signal. It should be realized that this system is strictly limited to the electrical elements, and must be made with the assumption that the hydraulic parameters have not changed.

The correct value of shunt calibration resistance for any voltage ratio output with any flowmeter, may be determined with the following equation:

$$R_c = \frac{250 R_g}{E_r} - \frac{R_g}{2}$$

where R_c = calibration resistance in ohms
 R_g^* = resistance of bridge (see data sheet)
 E_r = voltage ratio output in millivolts/volt excitation

***Note:** If the distance to the readout instrumentation exceeds approximately 20 feet, and R_c is applied at readout end of system, R_g must include resistance of bridge plus the resistance of lead wires A and D (or 1 and 4).

GENERAL NOTES

Flow surges may exceed the maximum rated electrical output by 100% for the Mark V before a permanent zero shift is noted. Since the force sensing element is linear, the zero point need only be reset.

Except for extreme conditions, no recalibration is generally required.

Due to the extremely high frequency response of the flowmeter, flow fluctuations and transients may be seen which cannot be detected by other systems of flow measurement. An apparent instability in the flowmeter may actually exist in the fluid system.

The flow range of any instrument may be varied, within certain limits, by the installation of a new target or, if an Aaliant amplifier is used with the flowmeter, by readjusting the amplifier gain. This feature means greater measuring scope and economy to the user. The flowmeter should never become obsolete. Consult the factory for details on this service. Do not disassemble the sealed sensing element as any unauthorized repairs will void the manufacturer's warranty.

THEORY

The instantaneous output of the strain gage bridge, E_{r1} , is directly and linearly proportional to the force, F , exerted on the target by the fluid flow. (Units defined at end of this section.)

$$E_{r1} = \frac{KF}{2.2046}$$

The force due to turbulent fluid flow is proportional to the velocity head, $V^2/2g$.

$$F = C_d A \rho \frac{V^2}{2g}$$

This equation applies to fluid flows where turbulence exists over the complete flow range of interest. Turbulence will exist in the vicinity of the target when the pipe Reynolds Number (R_D , see equation below) is 1000 or greater and will predominate throughout the pipe cross-section when R_D is 2000 or greater. The value of R_D above which turbulence will exist is approximate, since turbulence is dependent on pipe roughness, entrance conditions and other factors. If, at the low end of the flow range R_D is 2000 or greater, the output is unaffected by variations in fluid viscosity and affected only by changes in fluid density, ρ . If, at the low end of the flow range, R_D is between 1000 and 2000, the output for that part of the flow range may be affected by viscosity.

Laminar flow exists below $R_D = 400$ and a transition range exists between 400 and about 2000. The drag coefficient of the target, C_d , may vary in an unpredictable manner when R_D is in the transition or laminar regions. The low R_D can be brought about by low flow, high viscosity or both.

Although behavior in these regions may not always be predictable, it is repeatable if the flow conditions are held constant. An actual flow calibration by Aaliant can be provided to cover conditions such as those described.

A flowmeter can be calibrated with one fluid and then used with another fluid without loss of precision if the data are corrected for density change and the viscosities of both fluids are closely similar to keep R_D within the same range. With all other factors constant, electrical output will vary directly with fluid density.

Volumetric Units

$$E_2 = E_1 \frac{S_2}{S_1} \quad (3a)$$

$$Q_2 = Q_1 \sqrt{\frac{S_1}{S_2}} \quad (4a)$$

Gravimetric Units

$$E_2 = E_1 \frac{S_1}{S_2} \quad (3b)$$

$$W_2 = W_1 \sqrt{\frac{S_2}{S_1}} \quad (4b)$$

In the above equations, the voltage output may be obtained by multiplying the voltage output ratio, E_r , by the excitation voltage.

Pipe Reynolds Number is computed from any of the equalities below.

$$R_D = 50.6 \frac{Q_p}{d \mu} = 6.31 \frac{W}{d \mu} = 3160 \frac{Q}{d \nu}$$

Mark V Target Strain Gage Flowmeter

F = Force in pounds
C_d = Drag coefficient
A = Area of target (sq. ft.)
ρ = Fluid density, pounds per cubic ft.
V = Velocity through meter bore (ft. per second)
E₁ = Voltage output at calibration
E₂ = Voltage output, corrected for operating conditions
S₁ = Specific gravity at calibration
S₂ = Specific gravity of operating fluid
R_D = Reynolds number, for unobstructed pipe
Q₁ = Rate of flow, gallons per minute
Q₂ = Corrected rate of flow, gallons per minute
W₁ = Rate of flow, pounds per hour
W₂ = Corrected rate of flow, pounds per hour
d = Diameter of meter bore (inches)
ν = Viscosity, centistokes
u = Viscosity, centipoise
g = Gravitational constant = 32.2 feet/second/second
K = Force factor, millivolts per volt of excitation, per kilogram of force
E_{r1} = Instantaneous voltage ratio output in millivolts/volt of excitation

DIMENSIONS

IN-LINE

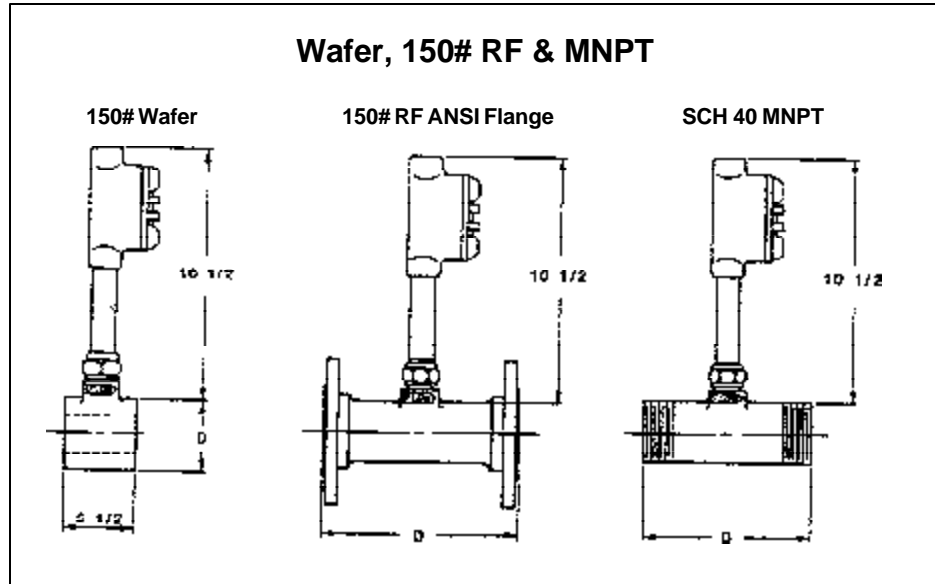

Size	D Dimension		
	Wafer	150# RF	MNPT
1/2"	1-3/4"	5"	4"
3/4"	2-1/8"	5"	4"
1"	2-1/2"	5"	5"
1-1/4"	2-7/8"	6"	6"
1-1/2"	3-1/4"	6"	6"
2"	4"	8"	8"
3"	5-1/4"	9"	9"
4"	6-3/4"	10-1/2"	—
6"	8-5/8"	12-1/2"	—

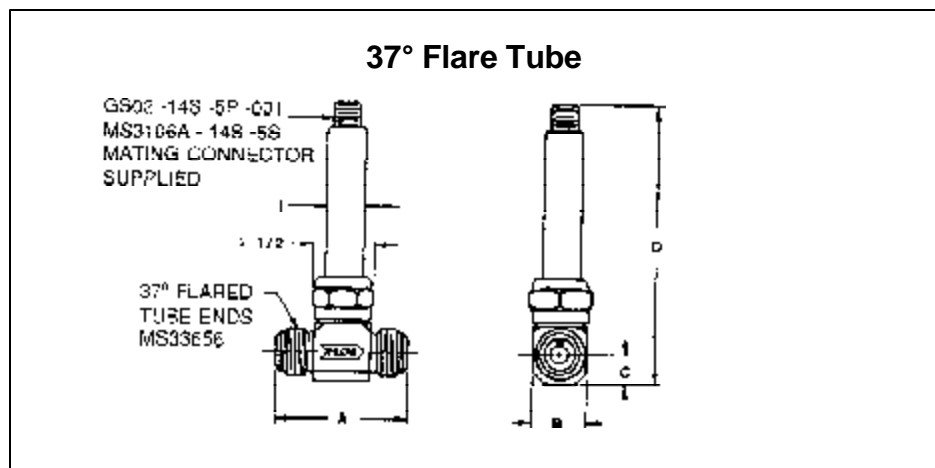

Size	A	B	C	D
1/2"	3.600	1-3/8	11/16	7-5/8
3/4"	3.600	1-3/8	11/16	7-5/8
1"	3.666	1-3/8	11/16	7-5/8
1-1/4"	3.666	1-11/16	7/8	7-7/8
1-1/2"	3.760	1-15/16	1	8-1/8
2"	4.260	2-9/16	1-5/16	8-5/8

Mark V Target Strain Gage Flowmeter

PROBE

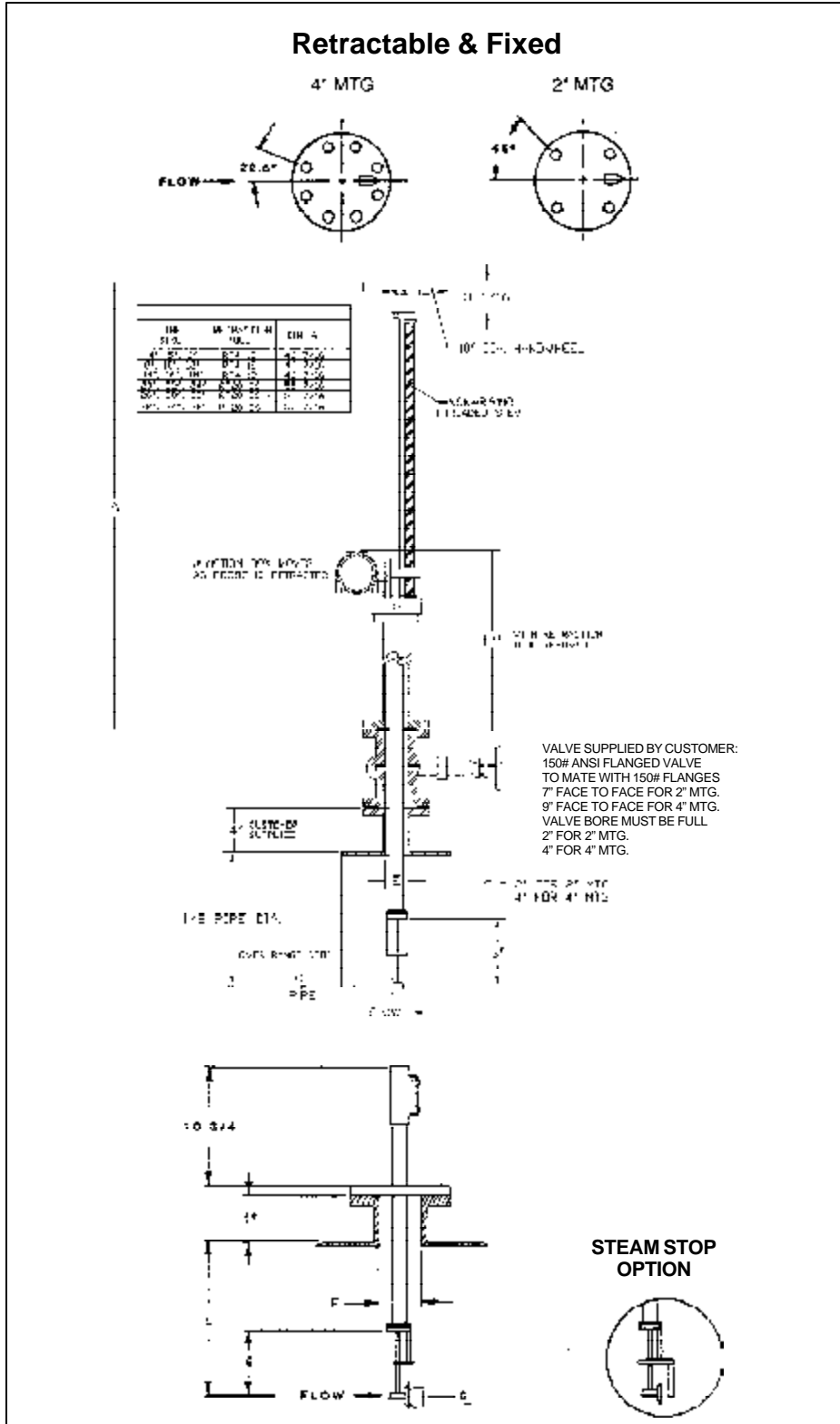

Size	2"	4"
E	2	3

Standard

MODEL/PART NUMBERS

IN-LINE AND PROBE UNITS

Model/Part Number

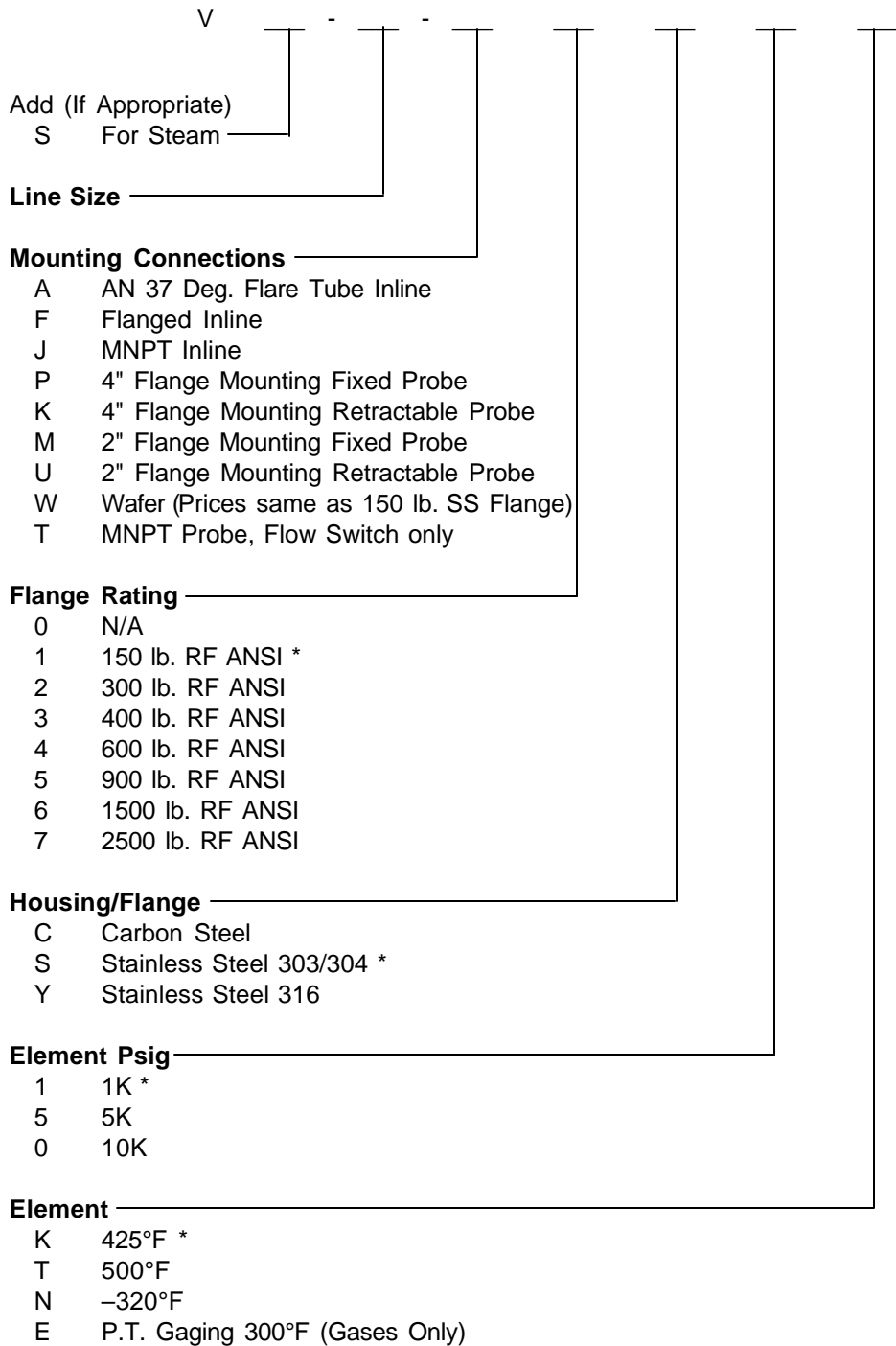

* Standard Construction
Consult factory for special applications or modifications not described.

GENERAL INFORMATION

FIELD CHECKING OF CALIBRATION ACCURACY

An important feature of the Mark V is the ease with which the retention of calibration accuracy can be checked in the field. By removing the flowmeter from the line and making two simple checks, it can readily be determined whether the calibration is unchanged. In addition to the normal components of the flow system, the following is required: (a) a digital voltmeter, capable of reading volts (up to 10) and millivolts (in the 20 mV range), (b) a precision vernier caliper or micrometer and (c) a weight of known mass.

At the time the flowmeter is calibrated by Aaliant, among the measurements made and recorded on the data sheet supplied with the flowmeter instruction book are these two: the target diameter and the force factor. If these measurements are unchanged, the calibration is unchanged. The sensor body (disc-shaped target) is sized and the edge contoured to obtain a desired drag in the moving stream of fluid. Comparison of the diameter of the disc at its edge with the diameter as measured when calibrated will show whether the drag is unchanged. The effect of the drag is to produce a force on the target support rod, resulting in an electrical output signal from the strain gage transducer in the flowmeter. The relationship of the force on the rod to the signal is called the force factor and is a measure of the system sensitivity. A comparison of the force factor to that recorded when calibrated will show whether the sensitivity is unchanged.

To make the checks, the flowmeter should be removed from the line and the target removed from the support rod. Note carefully which is the upstream face of the target. At this time, the diameter can be measured using a vernier caliper or micrometer. Note: On bidirectional targets, both the upstream and downstream edges should be measured. The "target type" listed on the data sheet includes a numerical suffix which is the diameter of the target in thousandths of an inch. For example ACR-405 is a target with a diameter of 0.405".

With the target still removed, fasten a thin wire to the rod at the point where the center of the target would be. Then clamp the flowmeter so that the normal flow direction is truly vertical and acting downward. Connect the flowmeter (terminals 1 and 4 or A and D) to the excitation voltage (terminals 1 and 2 on Aaliant's 1010/1020 transmitters) and apply power. Do not connect the flowmeter output terminals (terminals 2 and 3 or B and C) to the rest of the system. Using the digital voltmeter, measure and record the excitation voltage at terminals 1 and 4 and the output signal in mV at the flowmeter output terminals. This output signal is the zero load output. Hang a known weight, preferably 1 kilogram, from the thin wire. Record the resulting test load output signal as indicated on the digital voltmeter.

From the data, calculate the force factor:

$$\text{Force Factor} = \frac{\left(\frac{\text{test load output in mV}}{\text{excitation voltage in volts}} \right) - \left(\frac{\pm \text{zero load output in mV}}{\text{excitation voltage in volts}} \right)}{\text{weight in kg}} \times 1$$

Compare the force factor with that shown on the data sheet which is expressed in the units mV/V/Kg. The degree to which they compare will be influenced by the accuracy of the voltmeter, the accuracy of the weight, its location on the rod and the alignment of the flow direction with the true vertical. If these are accurate to 0.1% and the force factor and the target diameter each agree with the original values within 1% then it is likely that the flowmeter is within its original calibration accuracy.

The simplicity of the above procedure is unmatched by any other type of flowmeter. The advantages to the customer are further enhanced by the rugged construction and reliable performance of the flowmeters, most of which are in service for years without needing recalibration.

The following equipment is necessary for checking the calibration of your strain gage target meter: (1) a digital multimeter, capable of reading up to 20 milliamps, (2) a source of dc power for the two or three wire transmitter (12-40 volt range), (3) a weight of known mass.

The flowmeter must be removed from the line and the target removed from the rod. Care must be taken not to damage the target. Note which side is the upstream face of the target. Measure the diameter of the target disc using a vernier caliper or micrometer. Compare this value to the target size on your flowmeter data sheet.

Clamp the flowmeter so that the normal flow direction is vertical and acting downward. Fasten a thin wire to the rod where the center of the target should be. Gently push down on the rod where the target would be and release.

Insert the digital voltmeter in series with the plus side of the 4-20 mA dc output. Adjust the transmitter for the zero and span values according to the instruction manual (M723 for the Model 1050 or M561 for the Model TW).

**If the zero cannot be obtained, an offset resistor will have to be inserted between terminals 1 and 3 if the signal is too high, or 1 and 2 if the signal is too low.

Use an initial value around 1 megohm to start. Lowering the value of the offset resistor will drive the signal further in the desired direction. A value of around 15K ohms should be the minimum value used for large offsets.

Determine the full scale (FS) weight in grams using values from your data sheet in the following equation.

$$\text{Full Scale Wt.} = \frac{\text{FS mV/V Output}}{\text{Force Factor (mV/V/kg)}} * 1000$$

Use a known weight less than the full scale weight calculated. Use the equation below corresponding to the type of electronics you have to determine what your output should be when a known weight is hung from the rod of the target meter.

Model TWS Transmitter

$$\text{mA} = \left[\frac{\text{Known Weight}}{\text{FSWeight}} * 16 \right] + 4$$

Model TWL Transmitter

$$\text{mA} = \left[\sqrt{\frac{\text{Known Weight}}{\text{FSWeight}}} * 16 \right] + 4$$

Model 1050 Transmitter

$$\text{mA} = \left[\sqrt{\frac{\text{Known Weight}}{\text{FSWeight}}} * 16 \right] + 4$$

$$\text{Hz} = \sqrt{\frac{\text{Known Weight}}{\text{FSWeight}}} * 1000$$

$$\text{VDC@ TP 5} = \sqrt{\frac{\text{Known Weight}}{\text{FSWeight}}} * 10$$

Mark V Target Strain Gage Flowmeter

Model 1020 Indicator/Totalizer

$$mA = \left[\sqrt{\frac{\text{Known Weight}}{\text{FSWeight}}} * 16 \right] + 4$$

$$\text{Flow} = \sqrt{\frac{\text{Known Weight}}{\text{FSWeight}}} * \text{FS Flow}$$

Model 1100 Indicator/Totalizer

$$mA = \left[\frac{\text{Known Weight}}{\text{FSWeight}} * 16 \right] + 4$$

$$\text{Flow} = \sqrt{\frac{\text{Known Weight}}{\text{FSWeight}}} * \text{FS Flow}$$

VISCOSITY AND THE TARGET FLOWMETER

Two distinct types of flow in pipe are normally referred to – laminar and turbulent. Laminar flow is characterized by cylindrical layers of fluid which glide smoothly over each other. A dye injected in laminar flow would travel in straight lines. In turbulent flow the particles of fluid travel in a random motion. A dye injected in a turbulent situation would be dispersed throughout the pipe. The situation in which flow is in the process of change between laminar and turbulent or vice versa is referred to as the transition zone.

In the target flowmeter, the force exerted on the target by flow is given by the following.

$$F = C_d A_p \frac{V^2}{2g}$$

This equation applies to flows where turbulence exists over the complete flow range. Should the flow fall into the transition or laminar regions, the force exerted is given by different formulas. Therefore, if the flowmeter is calibrated for use in turbulent flow and subsequently used in laminar or transition flow, the output from the flowmeter will no longer be a square function as given by the above formula. However, an actual flow calibration can be provided to cover these conditions. To know when this special calibration is required, there must be a means of determining when laminar or transition flow will exist. This can be determined by calculating the pipe Reynolds number.

Reynolds number is the dimensionless combination of the pipe diameter and density, viscosity and velocity of flow. Put another way, it is the ratio of the dynamic forces of flow to the shear forces due to viscosity:

$$RD = \frac{DV\rho}{\mu}$$

A simplified form would be:

$$RD = 3160 \frac{Q}{d \nu}$$

where Q = flow rate in gpm
d = internal pipe diameter in inches
 ν = viscosity in centistokes

Turbulence will exist in the vicinity of the target when the pipe Reynolds number is 1,000 or greater. Laminar flow exists below RD = 400 and a transition range exists between 400 and 1,000. These numbers are approximate since pipe roughness, entrance conditions and other factors influence the condition of the flow.

If throughout the flow range the Reynolds number is greater than 1,000, the flowmeter output will be unaffected by variations in fluid viscosity. A water flow calibration will adequately describe the conditions of flow. For Reynolds numbers less than 1,000 a special calibration is required which simulates the conditions of flow. In other words, viscosity has an unpredictable yet repeatable effect at Reynolds numbers less than 1,000. The Reynolds number of the special calibration is made to match the customer's Reynolds number so that the unpredictable effects of viscosity are determined. It should be noted that the customer's viscosity must be maintained in order to maintain calibration accuracy. The change to a different viscosity requires a new calibration.

CORRECTION FACTORS FOR VOLUMETRIC GAS FLOW RATE WHEN OPERATING CONDITIONS CHANGE

A flow meter calibrated for use with a specified gas at given conditions of temperature and pressure can often be used to measure the flow rate when the operating conditions are changed. A change to a different gas can often be accommodated too.

There are three limitations:

- Do not apply higher pressures and/or higher temperatures that are beyond the limits of the flow meter internal design or the rating of the end connections. Check the flow meter data sheet.
- When the operating gas pressures exceed 100 psig, the ideal gas laws do not apply and the equations below must be modified by a super-compressibility correction factor. Refer to standard handbooks covering gas flows, or consult Aaliant.
- The new operating conditions must not cause the indicated flow rate to go beyond the original flow range. If it would, check with Aaliant on having the flow meter reranged.

Gas flow rates can be expressed two ways: (1) in ACFM, the actual cubic feet per minute of gas flowing at the operating temperature and pressure, or (2) in SCFM, the "standard" cubic feet per minute flowing at the operating temperature and pressure. The SCFM is a standard reference and indicates the flow rate in cubic feet per minute if the same weight of gas had been flowing at the "standard" conditions: 14.7 psia and 70 degrees F.

When the flow being measured uses a different gas or the operating conditions are changed, then the indicated flow rate must be multiplied by a correction factor to obtain the new flow rate. Choose the correction factor from the equations below depending on the units used in the original calibrations and the units desired for the new flow rate.

Original in SCFM, new in SCFM:

$$V_2 = V_1 \sqrt{\frac{G_1 P_2 T_1}{G_2 P_1 T_2}}$$

Original in ACFM, new in ACFM:

$$V_2 = V_1 \sqrt{\frac{G_1 P_1 T_2}{G_2 P_2 T_1}}$$

Original in SCFM, new in ACFM:

$$V_2 = V_1 \frac{14.696}{519.67} \sqrt{\frac{G_1 T_1 T_2}{G_2 P_1 P_2}}$$

Mark V Target Strain Gage Flowmeter

Original in ACFM, new in SCFM:

$$V_2 = V_1 \frac{519.67}{14.696} \sqrt{\frac{G_1 P_1 P_2}{G_2 T_1 T_2}}$$

V_1 = indicated volumetric flow rate, (equal to true flow rate at original calibration)

V_2 = volumetric flow rate at new conditions

G_1 = specific gravity of original gas

G_2 = specific gravity of new gas

P_1 = original pressure of gas at operating conditions, psi absolute

P_2 = new pressure of gas at operating conditions, psi absolute

T_1 = original temperature of gas at operating conditions, degrees Rankine

T_2 = new temperature of gas at operating conditions, degrees Rankine

(Degrees Rankine = degrees F + 459.67)

Note: Standard conditions are considered to be 14.696 PSIA and 60°F (519.67 R).

Air = 0.0764 lbs/ft³

Water = 62.3714 lbs/ft³

Note: If any of the three parameters, specific gravity, pressure or temperature are unchanged eliminate that parameter from the equations.

CORRECTION FACTOR FOR STEAM FLOW RATE WHEN OPERATING CONDITIONS CHANGE

A flowmeter calibrated for use with steam at given conditions of temperature and pressure can often be used to measure the flow when the operating conditions change.

There are two limitations:

- Do not apply higher pressures and/or temperatures that are beyond the limits of the flowmeter internal design or the rating of the end connections. Check the flow meter date sheet.
- The new operating conditions must not cause the indicated flow rate to go beyond the original flow range. If it would, check with Aaliant on having the flowmeter reranged.

When the steam operating conditions change, then the indicated flow rate must be multiplied by a correction factor to obtain the new flow rate:

$$W_2 = W_1 \sqrt{\frac{Vg_1}{Vg_2}}$$

W_1 = indicated rate of flow, pounds per hour

W_2 = flow rate at new conditions, pounds per hour

Vg_1 = specific volume of steam at original conditions

Vg_2 = specific volume of steam at new conditions

CORRECTIONS FOR CHANGE IN FLOWMETER SENSITIVITY (FORCE FACTOR)

At the time a flowmeter is calibrated by Aaliant, among the measurements made and recorded on the data sheet supplied with the flowmeter is the force factor. The force factor is a measure of the system sensitivity and arrived at by hanging a known weight, preferably 1 kilogram, from the lever arm of the flowmeter element at the point where the target is attached and recording the corresponding output in mV/V. A change in the force factor of a calibrated flowmeter, usually due to the replacement of the primary element, will affect

the accuracy of the flowmeter. However, a correction factor can be applied to offset the change in the system sensitivity thereby retaining the calibration accuracy.

The force factor correction (K) is equal to the ratio of the force factors:

$$K = \frac{F_1}{F_2}$$

where F_1 = original force factor
 F_2 = new force factor

After having arrived at a value for K, the application of the correction factor is then a function of the type of system in which the flowmeter is being used.

Should the flowmeter be used in a system without an Aaliant transmitter or signal conditioner, only the new full scale output of the flowmeter may be required. This can be arrived at as follows:

$$E_2 = E_1 \left[\frac{1}{K} \right]$$

where E_1 = original full scale output
 E_2 = new full scale output

Should the flow meter be used in a system with an Aaliant transmitter, then the signal levels to which zero and span (or CAL LO and CAL HI) are adjusted must be recalculated. It may also be desirable to recalculate the corresponding flow rates at the new calibration signal levels.

Model TWS and TWL

Adjust the zero control for 0.000 vdc output reading.

Calculate a new value for the span adjustment:

$$V_2 = V_1 K$$

where, V_1 = original cal. value vdc
 V_2 = new cal. value

Model 1050

Adjust the zero control for 0.0 vdc.

Calculate a new value for the span adjustment:

$$E_4 = E_3 \sqrt{K}$$

where, E_3 = original cal. value (vdc)
 E_4 = new cal. value (vdc)

REMOVAL AND REPLACEMENT OF SENSING ELEMENT ASSEMBLY

IN-LINE FLOWMETERS

Removal of Sensing Element Assembly

The flow sensor or target must be removed from the lever rod inside the line housing before the sensing element can be removed. Do not attempt to remove the sensing element without first removing the target.

The target is fastened to the rod by means of a socket head set screw only on very small units, or by a socket head cap screw and locking nut on larger units.

If a locking nut is evident on the downstream side of the target, loosen it with a nut driver. Select an Allen wrench to fit the socket head screw and back out the screw until the target falls free from the lever rod. The edges on the disc of the target should be protected from nicks, scratches, or other damage.

Unscrew the retaining nut and remove the sensing element from the line housing.

Reassembly of Sensing Element into Housing

Check to ensure that an "O" ring is in position inside the threaded mounting adapter.

Thread the screw part way into the target so that it does not protrude into the hole for the lever rod.

Holding the target assembly by means of an Allen wrench inserted into the socket head screw, position the target inside the line housing from the downstream side so that the lever rod hole is in line with the hole through which the sensing element is inserted.

Assemble the sensing element into the line housing through the threaded adapter so that the lever rod goes into the target assembly being held in position inside the line housing.

The sensing element must be oriented so that the alignment steps are engaged. The alignment steps are located where the sensing element engages the adapter on the line housing in the area normally hidden by the retaining nut.

Adjust the target on the lever rod so that the machined end of the socket head screw will nest into the hole in the end of the lever rod. Tighten the screw and tighten the locking nut if one is provided. The target disc must be on the downstream side of the lever rod.

Tighten the retaining nut which secures the sensing element into the line housing.

PROBE FLOWMETERS

Caution: When assembling or disassembling or otherwise handling the Mark V Flowmeter Probe, do not allow the weight of the Probe to rest on the target or its supporting lever rod, and do not apply force to the target or its supporting lever rod.

Removal of Sensing Element Assembly

Remove the cover from the junction box at the top of the probe and disconnect the four leads from the terminal strip.

Using any suitable pick or knife, remove the potting compound from inside the junction box so that the lead wires can be subsequently withdrawn. Use care so that the lead wires are not cut or otherwise damaged.

Supporting the target so that force cannot be transmitted to its supporting lever rod, open the tab lock washer and remove the hex head screw which fastens the target to the lever rod. Remove the target.

Open the two tab lock washers and remove the hex head screws securing the mechanical stop plate to the supporting posts.

Unscrew and remove the two mechanical stop posts.

Remove the three socket head cap screws which secure the sensing element assembly into the lower end of the probe case. On some special probes, these may be hex head cap screws secured with locking tabs.

The sensing, element can now be withdrawn and removed from the probe.

Assembly of Sensing Element into Probe Housing

Insert the four lead wires into the lower end of the probe case and position the sensing element assembly so that the screw holes in the sensing element adapter and probe collar are aligned. The four lead wires should be accessible inside the junction box at the top end of the probe.

Assemble the three 10-32 X 3/8 socket head cap screws which secure the sensing element assembly into the probe.

Thread the two mechanical stop posts into the remaining two holes in the lower end of the probe assembly.

Reassemble the mechanical stop bracket to the posts using the 8-32 hex head screws and locking tabs. Crimp two opposite ears of the tab over the hex head screws and the center ear up over the mechanical stop bracket.

Slide the target onto the end of the lever rod and secure with 6-32 hex head screw and tab lock washer. The target disc must be on the downstream side of the lever rod. Force must not be applied to the lever rod when tightening the screw and crimping the locking tab.

Reconnect the lead wires to the terminal strip inside the junction box as follows:

<u>Lead Wire No.</u>	<u>Color</u>	<u>Terminal Strip No.</u>
1	Green	1
2	White	2
3	Red	3
4	Black	4

Mark V Target Strain Gage Flowmeter

Using a silicone rubber compound, duct seal or other appropriate sealing compound, seal the area around the lead wires as they enter the junction box from the probe case.

The Flowmeter Probe should now be ready for installation and setup.

venture
MEASUREMENT

Cage Code# 1MU21

150 Venture Boulevard Spartanburg, SC 29306
Phone: 800-778-9251 Fax: 574-8063

M715 Rev. A