

**Model 1050 Strain Gage  
Transmitter  
Installation & Operation Manual**

(Cage Code #1MU21)



# Model 1050 Strain Gage Transmitter Installation & Operation Manual

## CONTENTS

- I. GENERAL ..... 1
- II. INSTALLATION ..... 2
- III. SPECIFICATIONS..... 3
- IV. WIRING..... 4
- V. SET UP & OPERATION..... 6
- V. DIMENSIONS ..... 8

## I. GENERAL

The Model 1050 is a signal transmitter for use with the Mark V and Mark VII strain gage target flowmeters. When supplied with a DC voltage, the Model 1050 provides an output signal that is proportional to the flow rate through the Mark V. The signal from the meter is converted to either DC voltage or current and frequency output signals.

## II. INSTALLATION

Normally, the Model 1050 will arrive mounted on a Mark V strain gage target meter and will be wired to the strain gage bridge. (The only exception should be for remote mounting due to accessibility or unusual environmental conditions.) After mounting the target meter, field wiring to the readout instrument must be added. To complete the installation, the meter calibration should be checked.

Note: In high temperature applications such as steam, do not insulate the Model 1050. By not insulating, the heat will be allowed to dissipate and keep the internal electronics cooler. Also, the unit will be more serviceable.

Note: Signal conditioner boards are assigned to a particular serial number and should remain as a set; calibration error may occur if boards are interchanged with those from another serial number.

### III. SPECIFICATIONS

Features: Low flow cut off; flow inputs below the usable portion of the input range will be suppressed to zero.

Input: Strain gage bridge

Output: Analog: 4-20 mA (std.)

0-20 mA

1-5 VDC

0-10 VDC\*\*

Digital: 0-1000 Hz (std.)

Load impedance: 600 $\Omega$  maximum for current output at 24 VDC\*

Power: 12-36 VDC standard; 100 mA at 12 VDC; 60 mA at 24 VDC (plus 4-20 mA, if used)

Temperature: 32 $^{\circ}$  - 140 $^{\circ}$  F (0 $^{\circ}$  - 60 $^{\circ}$  C)

Accuracy:  $\pm 0.1\%$  of full scale

Repeatability:  $\pm 0.25\%$  point

Electrical connections: Through  $\frac{3}{4}$ " NPT hole; four position terminal block for input power and two output signals

Wiring lengths: Up to 75' for remote mounting from target meter to Model 1050; up to 5000' from 1050 to instrumentation

Enclosure: Mounted in explosion proof watertight housing (rated Class I, Groups B, C & D; Class II, Groups E, F & G; Class III; NEMA 4)

Weight: 4 lbs.

Warranty: Standard one year.

\*The Model 1050 has a maximum load of 500 $\Omega$  if the supply voltage is at least 14 volts. But if a supply voltage of less than 14 volts is used, the maximum load drops (for example, to 400 $\Omega$  at 12 volts). The voltage should be measured at the Model 1050, not at the power supply itself. Make sure that the field wiring is of low enough resistance to meet voltage requirement.

\*\*With factory modification.

## IV. WIRING

Caution: This is a three (3) wire device. Incorrect wiring of this device may cause permanent damage. Disconnect power before removing or inserting PC boards. Failure to do so can damage the PC boards.

Three wires are needed between the Model 1050 and the receiving instrument. The wires are ground (circuit common), supply voltage (12 to 36 volts), and the signal output. The signal output can be a 4-20 mA and/or a 0-1000 Hz signal. They exist on separate output terminals, and both signals may be used if necessary. A fourth wire is required if both signals are used. See Figure 1 for possible hookup arrangements.

Care must be taken to avoid exposing wiring to any source of electrical interference. Methods of doing this include installation in conduit, use of shielded wiring, and the routing of wiring away from known noise sources such as welders, radio transmitters, etc. Shielded cable should be grounded at one end only. We recommend grounding at the signal source. In a high radio noise environment, conduit may be needed to get maximum isolation from RF noise. Keep all wiring in metal conduit and metal boxes wherever possible. Any breaks should be as far from the meter and RF sources as possible.

Care should be taken so that wires do not interfere with box cover replacement.

Figure 1: Wiring Diagram

### General Hookup

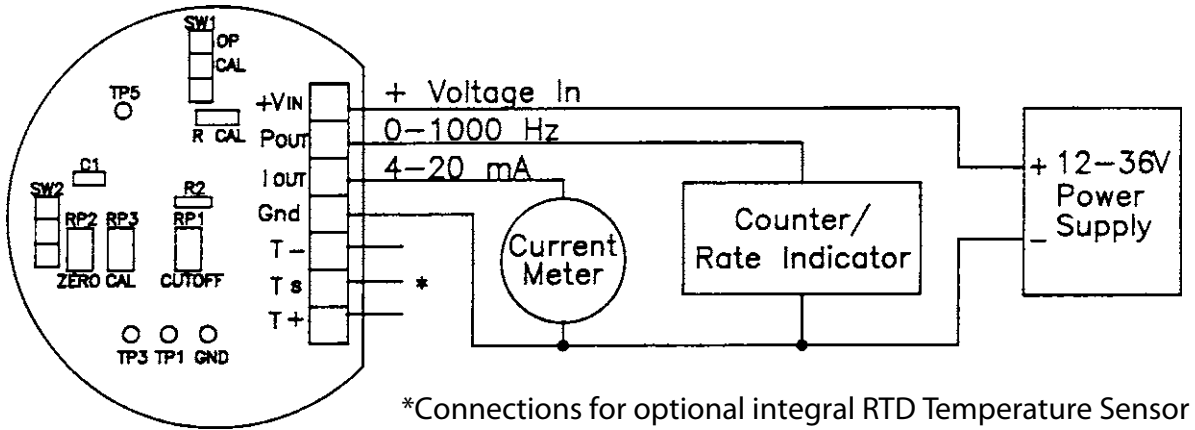

### Models 1030, 1530, and 3030

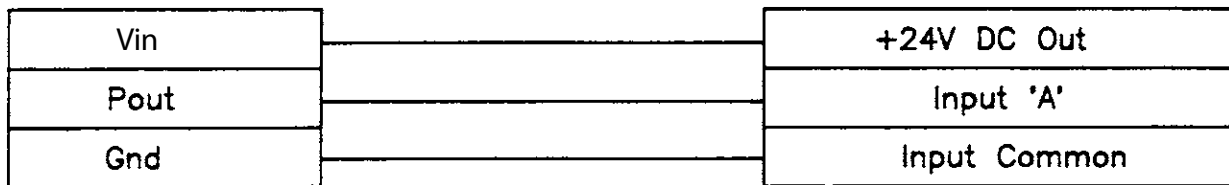

Do not connect the 24 VDC out terminal of the Model 1030/1530/3030 to the Model 1050 if the 1050 is powered from another source. For connections from the flow meter to the Model 1050, see general hookup wiring diagram. For other connections to the Model 1030/1530/3030, refer to the respective manual.

### Remote Mounting

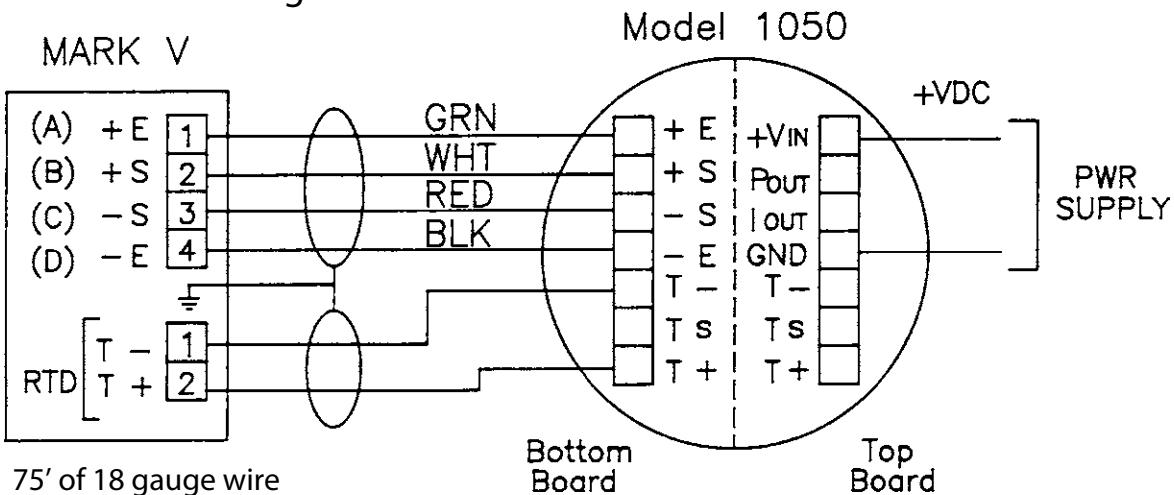

75' of 18 gauge wire



## V. SET-UP AND OPERATION

This procedure must be performed after the Mark V strain gage target meter and the Model 1050 have been installed. A digital volt meter (DVM) is required.

Caution: Disconnect power before removing or inserting PC boards. The wiring terminal connector may be removed and replaced for easier accessibility. Do not wire with power on. Always connect the ground wire first and disconnect it last.

Be sure the meter is properly installed and in its final operating position. **There must be no flow while calibration is in progress.**

**All of the potentiometers, test points, and header switches referred to in the following instructions are on the top board unless otherwise noted.**

See Figure 2 to locate their exact positions.

1. Hook up the DVM between circuit common (GND) and TP3.
2. Be sure SW2 is in the F (fast) position. Note original position.
3. Be sure SW1 is set in the OP position.
4. Adjust the pot RP2 (labeled zero) to get 0.000 volts on the DVM.
5. Move the DVM lead from TP3 to TP5.
6. Move SW1 to the CAL position.
7. Adjust pot RP3 (labeled CAL) to the value shown on the calibration record under "TP5 (0-10V) \_\_\_\_\_ VDC."
8. Repeat steps 2-5 until no further change is noted.
9. Return SW1 to the OP position.
10. Return SW2 to its original position.

Note: Steps 1-3 must be performed when the flowmeter is installed, removed and reinstalled, or changed in position in any way. The rest of the procedure need only be done as a periodic check on the meter calibration.

Note: SW2 selects either a fast or slow response to any change in input. Because of possible noise pickup, it is recommended that SW2 be left in the slow (SL) position. It can be moved to the fast (F) position if a quicker response to changes in the flow rate is required.

"Cut-off" is a drop-out adjustment point that makes the transmitter output zero below the accurate range of the meter. The cut-off is factory set to its optimal value. It is set by adjusting RP1 while reading the voltage on TP1. Adjusting the cut-off is strongly discouraged. Under no condition should it be set lower than 0.4 VDC. Consult factory.

Figure 2: Jumper and Potentiometer Locations

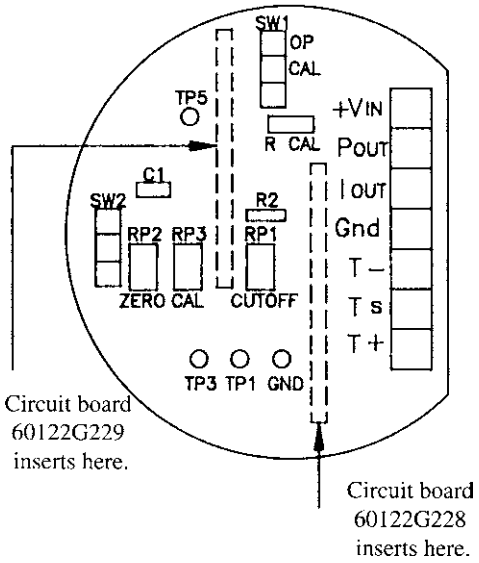
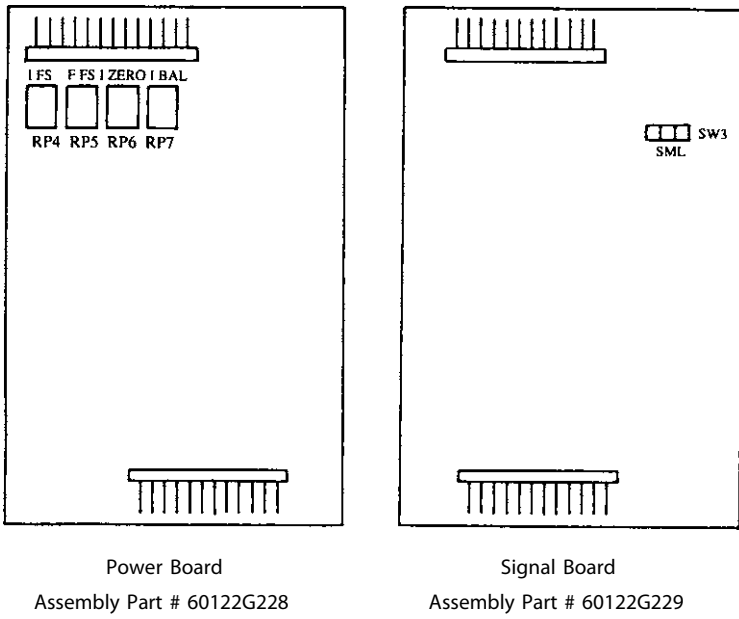

Adjustment Board  
Assembly Part # 60122G227

## VI. DIMENSIONS

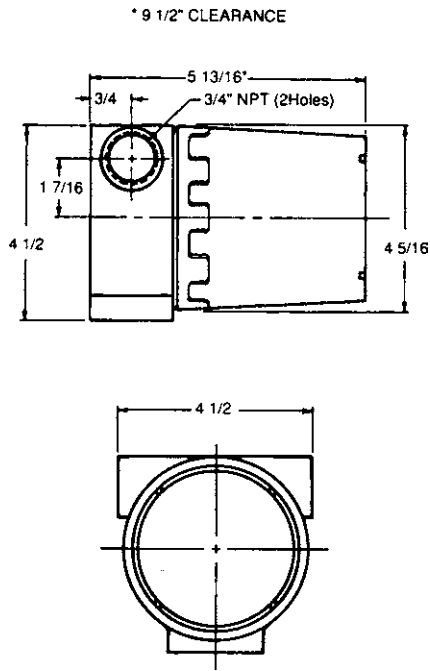



150 Venture Boulevard  
Spartanburg, SC 29306  
Tel: (800) 778-9242  
Fax: (864) 574-8060  
sales@bindicator.com  
www.bindicator.com

**venture**  
MEASUREMENT

2012 All rights reserved.  
All data subject to change without notice.

M725 Rev C