



Model R-35
Mechanical Batch Controller

**Installation, Operation,
& Maintenance Manual**



General

The R-35 Mechanical Batch Controller is a device that provides automatic batch control with two-stage mechanical shut-off. The unit consists of a meter register and a preset register mechanically linked to a ball valve.

The meter register is a large digit resettable register designed for commercial and industrial applications. The unit features both a single transaction, 5-digit resettable register, and an 8-digit nonresettable totalizing register. The aluminum and steel enclosure is moisture proof, dust resistant, and finished in corrosive resistant grey/green epoxy to provide a weather-tight housing for all types of operating environments.

The preset register is a 5-digit resettable product quantity control batch device. The preset register is mechanically coupled to a stainless steel or bronze ball valve.

Specifications

Temperature: 180°F maximum

Units or Registration: Calibration in US gallons, pounds, Imperial gallons, liters, or other units where the mechanism permits

Register Specifications:

Case: Die cast aluminum and steel

Gears: Phenolic

Bushings: Porous bronze

Totalizer Wheels: Acetal resin

Valve Specifications:

1" or 2" stainless steel

1", 1-1/2", or 2" bronze

Installation

The R-35 mechanical batch controller is mounted to the meter at the factory, and is ready for installation/operation upon arrival.

It is important that the meter not be lifted by the preset register and totalizer assembly when handling the meter.

Operation

The Niagara Model R-35 Mechanical Batch Controller provides batching by controlling the closing of a ball valve connected by a mechanical linkage to the preset register.

Important: Slowly open an upstream valve to the meter and allow a few gallons of the process fluid to pass through the meter. Since air will register as a liquid, it is necessary to vent all air from the meter cavity.

The Meter Register:

Meter registers are supplied with a 5-digit delivery register and an 8-digit totalizing register. The delivery register is resettable to all zeros by turning the setback knob clockwise. **Do not reset totalizer when there is flow through the meter.**

Model R-35 Mechanical Batch Controller

Preset Register Operation:

1. Push tan button until latched.
2. Push black preset buttons until desired quantity appears.
3. Pull valve handle back/down past the full open position to release the set button and start flow. Valve will return to full open.
4. While in operation, the preset register will count down, indicating quantity yet to be delivered. The resettable register will indicate actual quantity delivered.
5. When the first-stage knock-off number is reached, a latch is released and the preset ring moves back 15°45' partially closing the valve.
6. When the figure rollers reach zero, the final latch releases and closes the valve.
7. For emergency stop, press the red stop button. The stop button will actuate both the first and final stages of the valve to provide complete shutdown. To resume batching, reopen the valve (Step 3).

NOTE: Minimum batch size 50 independent of gallons or pounds, etc.

Maintenance

Each mechanical batch controller is individually calibrated before shipment. After the unit is set, peculiarities of the operating conditions may cause a small constant error, or the meter may become slightly inaccurate after long service. If this happens, it may be corrected as follows: test carefully, record the exact results, fill out a test report, and ship the meter, register, and test report to Venture Measurement Company. We will then calculate and install a new gear ratio between the meter and register to correct the reported error.

Optional Knock-off Switch Data

Warning: In installation and use of this product with an electrical switch, comply with the National Electric Code, federal, state and local codes, and/or any other applicable safety codes. In addition, turn off power and take other necessary precautions during installation, service, and repair to prevent personal injury and equipment damage.

The explosion-proof switch housing mounts directly to the register preset and is actuated by a mechanism connected to a ring at the base of the preset. Four switches are mounted inside the housing. These may be wired normally open or normally closed. The switches have screw type terminal connections. Ratings are SPDT, 15 amps at 125/250 volts AC, or 0.5 amp at 125 volts DC, and 0.25 amp at 250 volts DC. The switch box extends 5-1/8" from the back of the preset to the 0.75" NPT conduit connection. Additional clearance should be allowed to complete hard conduit connections into the switch box. Two switches are available for control at the full flow rate and two switches at the end of the cycle. These can be used for pump start and shutdown or for operating lights. See Illustration 2 on the next page for wiring diagram of pump control circuit and operating lights.

Model R-35 Mechanical Batch Controller

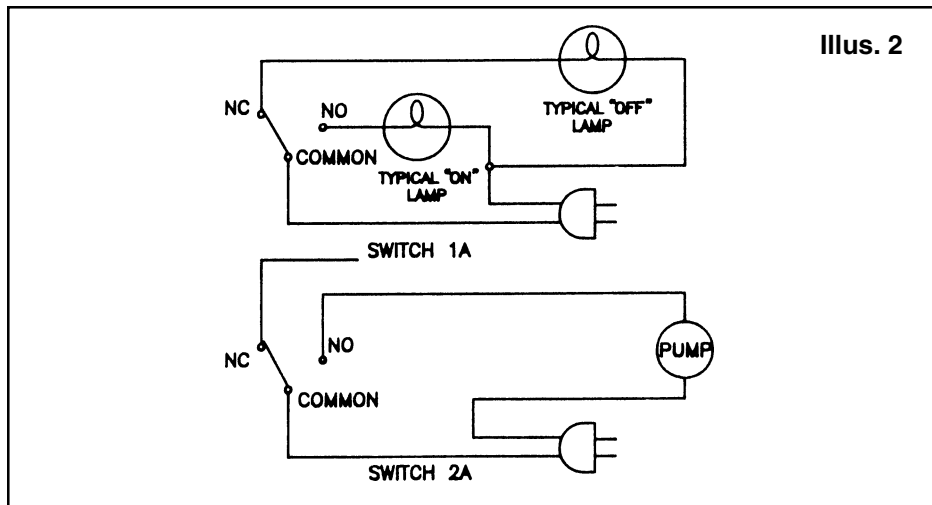
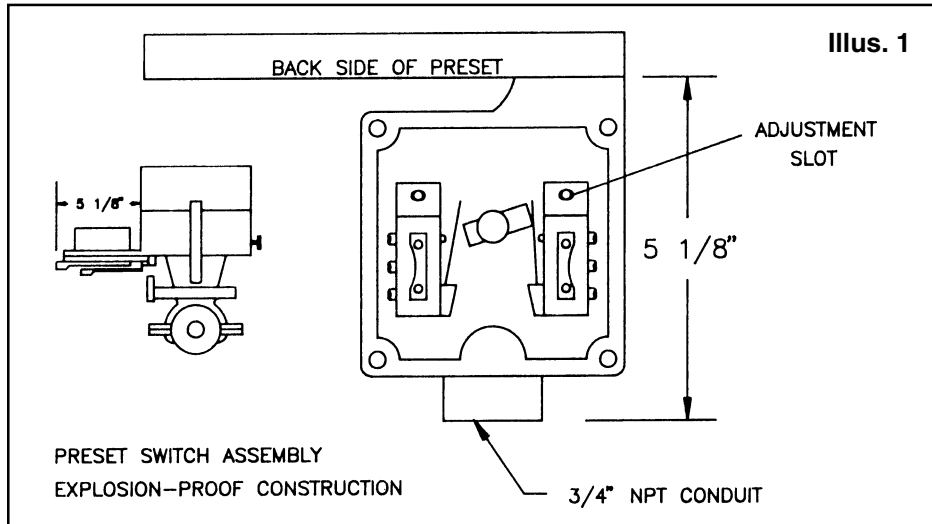

150 Venture Boulevard
Spartanburg, SC 29306

Phone: (800) 778-9251, (864) 574-3327

Fax: (864) 574-8063

Internet: www.aaliant.com

E-mail: sales@aaliant.com

venture
MEASUREMENT