

## SPECIFICATIONS

### Time Ranges

SYM.	MAXIMUM RANGE	MINIMUM SETTING
1	99.99 Sec	.01 Sec
2	999.9 Sec	.1 Sec
3	99 Min:59 Sec	1 Sec
4	99.99 Min	.01 Min
5	999.9 Min	.1 Min
6	99 Hr:59 Min	1 Min
7	99.99 Hr	.01 Hr
8	999.9 Hr	.1 Hr

### Batch Counter Range

1-9999 or continuous.

### Setting Accuracy

Time —  $\pm 0.05\%$  of setting or 50ms, whichever is greater  
Count — 100%

### Repeat Accuracy

Time —  $\pm 0.001\%$  of setting or 35ms, whichever is greater  
Count — 100%

### Power On Response

200 milliseconds maximum

### Reset Time

15 milliseconds

### Operating Temperature

+32° to +122°F (0° to 50°C)

### Operating Voltage/Frequency

SYMBOL	VOLTAGE & FREQUENCY
A6	120 VAC 50/60 Hz
B6	240 VAC 50/60 Hz

### Sensor Power Supply

+12 VDC, 75 milliamps

### Output Rating

Relay: 5 Amp (resistive), 10 to 264 VAC

### Vibration

Unit function is unaffected by 2.5g sinusoidal vibration magnitude in both directions of the perpendicular mounting axes imposed from 10 to 100 Hz.

### Static Discharge

Unit function is unaffected by a constant 3600 volt peak, 60 Hz discharge applied to the grounded front plate at a relative humidity of less than 25%.

### Transient Protection

Immune to 2500 volts peak transients up to 50 microseconds in duration.

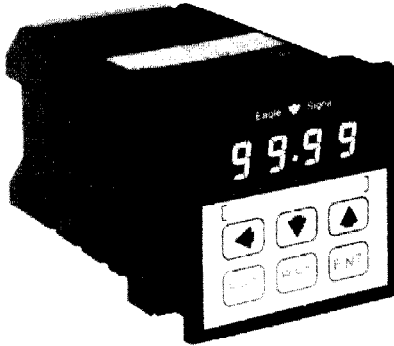

The SX160 is a microprocessor based control that combines a repeat cycle timer with an internal batch counter. The batch counter counts the number of repeat cycle operations that the timer performs. The batch counter has its own programmable output, and automatically stops the repeat cycle timer operation after the user programmed number of cycles.

The repeat cycle timer function has a SPDT relay output. The setpoints for the output ON and OFF times are individually programmable. There are eight time ranges available for the repeat timer function from 99.99 seconds to 999.9 hours.

The internal batch counter has its own SPDT relay output with two programmable operating modes. The batch counter output can operate in either an On Delay or Interval mode. The batch counter can be set to allow from 1 to 9999 cycles, or it can be set to provide continuous repeat cycle operation.

The SX160 is housed in a standard DIN case (68mm square cut-out). The case and front bezel require minimal panel space, yet provide easy to use programming keys and an easy to read .36 inch LED display.

The operating modes and time ranges for the unit are programmed using rocker switches on the back of the unit. This programming method provides both simplicity and security. The front panel display has a prompted programming routine that prompts the user when to program the ON and OFF times as well as the batch counter setpoint.

Some of the other features of the SX160 Timer include:

- NEMA 4 Hosedown Test rated.
- Two 5 Amp SPDT relay outputs.
- Two output operating modes for the repeat cycle timer.
- Two output operating modes for the batch counter.
- Eight time ranges for the ON and OFF time.
- Time inhibit input.
- LED indicators for output status.
- Setpoint to zero or zero to setpoint cycle progress indication.
- Front panel and remote reset inputs.
- Keypad lock function.
- Non-volatile memory (NOVRAM) for program and data retention.
- Removable terminal blocks for wiring connections.

## CONTROL INPUT FEATURES

The **SX160 Timer** uses line voltage control inputs for high noise immunity.

The start input enables the timer and batch counter and initiates the programmed output sequences. This allows the timer operation to be started independently of when power is applied to the unit. This input can be set up to respond to sustained or momentary inputs.

When power is applied to the inhibit input, the time cycle stops and the outputs are held in their last state. The inhibit condition will continue as long as power is applied to the inhibit input or until the unit is reset.

When power is applied to the reset input, the timer and batch counter reset and the outputs are de-energized. The reset and output de-energized state will continue as long as power is applied to the reset input. A front panel reset key is also provided for manual reset operation. The front panel reset key can be disabled using the keypad lock function.

All inputs are optically isolated and designed to respond in 15 milliseconds or less.

A 12 VDC 75 milliamp power supply is provided for user convenience although the **SX160 timer** uses line voltage inputs.

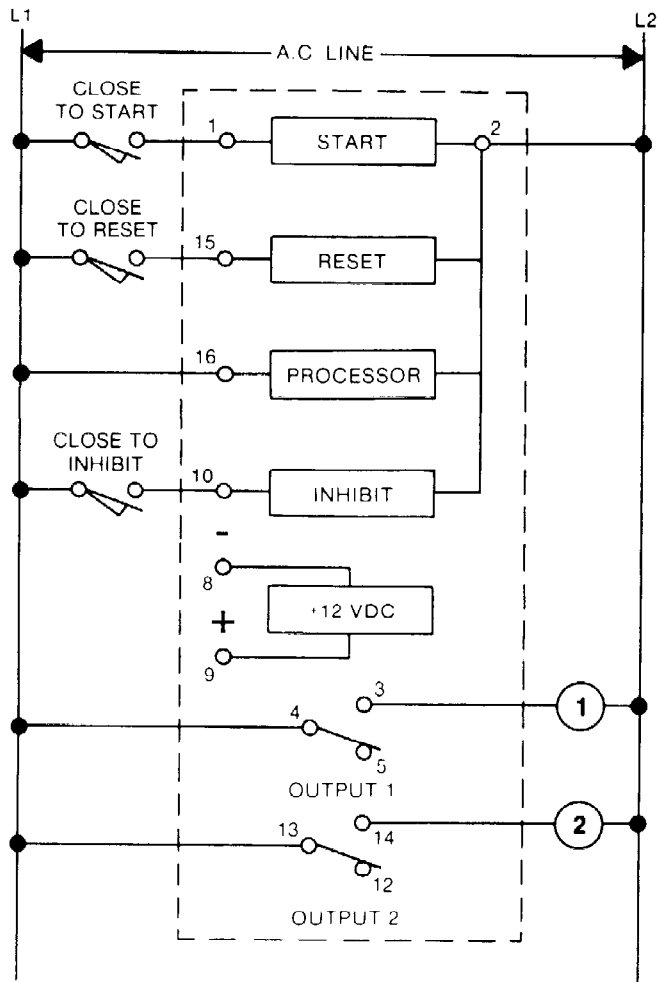

## OUTPUT OPERATING MODES

Output 2 is a SPDT relay output that always operates in the repeat cycle timing mode. Setpoint 1 (SEt1) is the OFF time and occurs first. Setpoint 2 (SEt2) is the ON time. In two of the output operating modes Output 1 is the SPDT relay output for the batch counter. In the third operating mode Output 1 is programmed to provide an output during the OFF time interval (SEt1). In this operating mode the batch counter controls the number of cycles, but does not provide an output function.

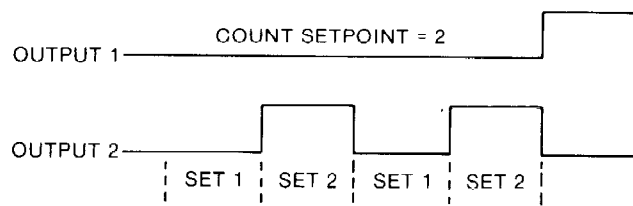

**1. On Delay Counter Output Operation** — Output 2 performs the repeat cycle timing operation. Output 1 energizes at the end of the programmed number of repeat operations.

**2. Interval Counter Output Operation** — Output 2 performs the repeat cycle timing operation. Output 1 energizes at the beginning of the repeat cycle operation and remains energized until the programmed number of repeat operations is completed.

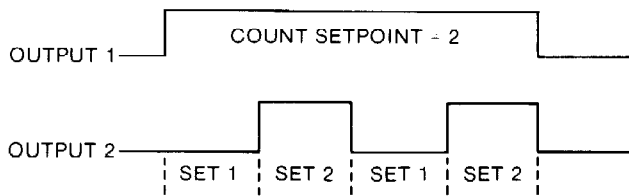

**3. Repeating Sequence Intervals** — Output 1 and Output 2 provide repeat cycle timing operation. Output 1 is on during the interval of Setpoint 1 (SET1). Output 2 is on during the interval of Setpoint 2 (SET2). The batch counter controls the number of repeat cycle operations, but does not have an output function.

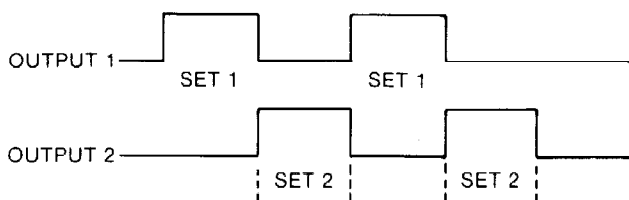

### BATCH COUNTER OPERATION

The internal batch counter counts the number of actuations of Output 2. The batch counter can be programmed to provide a fixed number of repeat cycle operations from 1 to 9999. If the batch counter is set to 0000, the repeat timer operation will continue until the unit is reset.

### RESET OPERATION

The SX160 Timer is programmable to either reset on power interruption and start over when power is reapplied or to retain its actual cycle progress value and continue with the cycle when power is reapplied. The reset operation applies to both the timing function and the batch counter. This operation is determined with a switch setting on the back of the unit.

### CYCLE PROGRESS INDICATION

The time progress display can be programmed either to cycle DOWN from the setpoint to zero or to cycle UP from zero to the setpoint. The operation of the cycle progress display is determined with a switch setting on the back of the unit.

### START INPUT OPERATION

The SX160 Timer uses line voltage applied to terminals 1 and 2 to initiate the timing cycle. The start signal can either be a sustained voltage input or a momentary voltage pulse. When the sustained start input mode is used, removal of power from terminals 1 and 2 will stop the timing cycle. When the momentary start pulse mode is used, the timing cycle is initiated by the voltage pulse, and the timing cycle continues even if the signal is removed. The timer and batch counter can be reset either by using the front panel reset (RST) key, or by applying a reset signal on terminal 15. The operation of the start input is determined with a switch setting on the back of the unit.

### FRONT PANEL PROGRAMMING

The SX160 Timer uses a sealed front panel keypad for entry of the ON and OFF time and the batch counter setpoints.

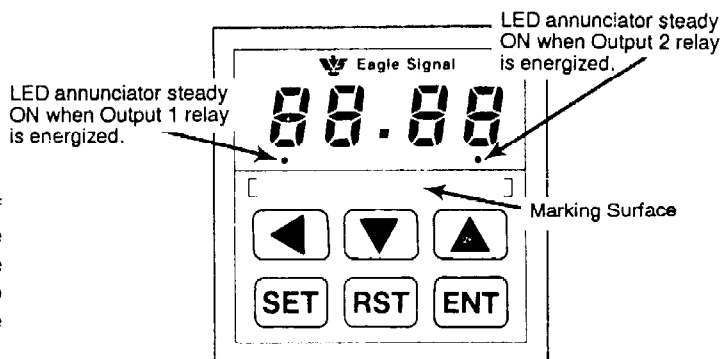

Pressing the SET key calls the prompted programming routine for the three setpoints. These are indicated with "SET1" and "SET2" and "rEPT" prompts. Each setpoint is displayed with the least significant digit flashing. The position of the flashing digit can be changed using the ◀ key. The ▲ and ▼ keys increment and decrement the value of the flashing digit. The ENT key enters any setpoint changes into memory.

A keypad lock function is provided for security. Pressing and holding the ENT key for about five seconds will alternately lock and unlock the front keypad. When locked, the SET key will call the three setpoints, but the ◀, ▲, and ▼, and RST keys will be inoperative.

The RST key is a manual reset. Pressing the RST key resets the timer and the batch counter, and holds the outputs in their normal, deenergized states until the key is released. The front panel reset key can be disabled using the keypad lock function.

## SWITCH PROGRAMMING

The SX160 Timer uses eight miniature rocker switches on the back of the unit to program the operating modes as follows:

X = Switch ON O = Switch OFF Blank = Does Not Apply

SYM.	OPERATING MODE	SWITCH NUMBER							
		1	2	3	4	5	6	7	8
OUTPUT OPERATION									
1	ON Delay Counter Output	X	O						
2	Interval Counter Output	O	O						
3	Repeating Intervals	O	X						
CYCLE PROGRESS									
1	DOWN - From setpoint to zero			O					
2	UP - From zero to setpoint			X					
TIME RANGES									
1	99.99 Seconds				O	O	O		
2	999.9 Seconds				X	O	O		
3	99 Minutes:59 Seconds				O	X	O		
4	99.99 Minutes				O	O	X		
5	999.9 Minutes				X	O	X		
6	99 Hours:59 Minutes				X	X	O		
7	99.99 Hours				O	X	X		
8	999.9 Hours				X	X	X		
RESET OPERATION									
1	Reset on Power Interruption							O	
2	Non-Reset on Power Interruption							X	
START OPERATION									
1	Sustained Start Input								O
2	Momentary Start Input								X

## TERMINAL ASSIGNMENTS

The SX160 Timer uses two removable terminal blocks to provide wiring connections, with the following terminal assignments.

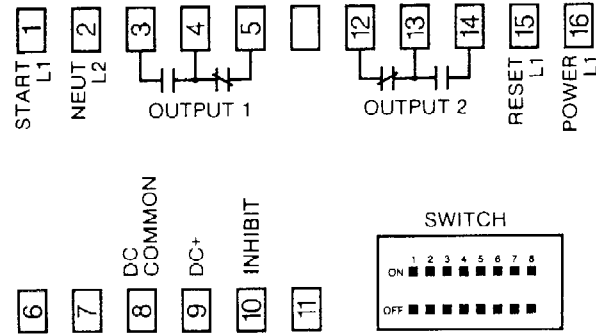

Terminals 6, 7, and 11 are not used on the SX160 timer.

For more information, refer to the SX160 Instruction Manual, publication number 5005-805.

## MOUNTING

The SX160 Timer uses two removable mounting clips with adjustable screws to mount the enclosure in a panel as shown below.

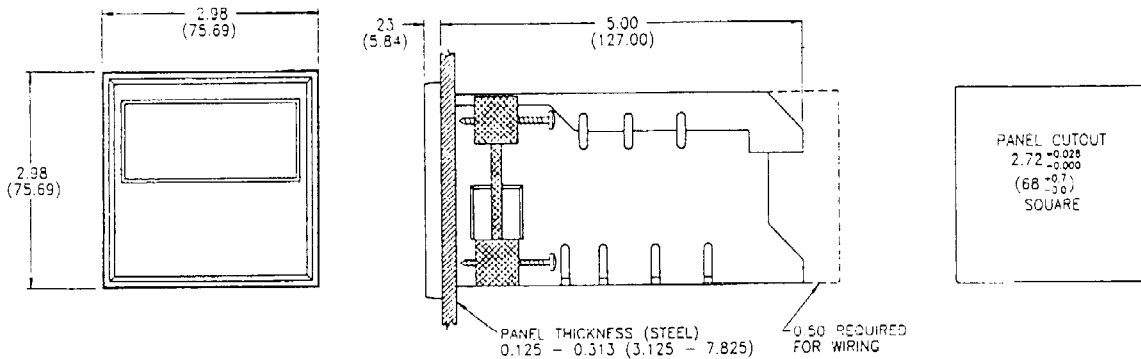

## ORDERING INFORMATION

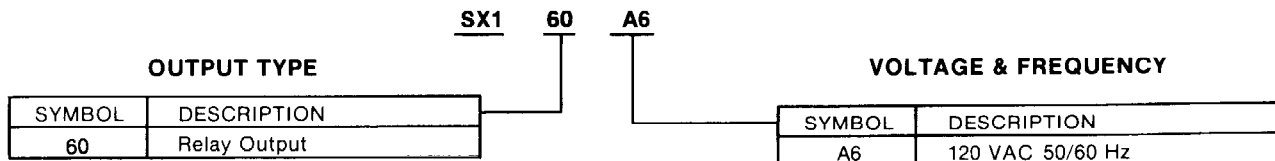

## ACCESSORIES

PART NUMBER	DESCRIPTION
FFD10969P003	1/4 DIN adapter Plate

PANEL CUTOUT  
2.72<sup>+0.028</sup>  
-0.000  
(68<sup>+0.7</sup>  
-0.6)  
SQUARE

## Dynapar, Veeder Root, and Eagle Signal Brands:

Sales, Repair, and Application Support:  
1675 Delany Rd.  
Gurnee, IL. 60031  
847-662-4150 Sales/Order Entry Fax  
847-782-5277 Applications Support Fax  
800-873-8731 Sales/Order Entry  
800-234-8731 Applications Support

## NorthStar Brand:

Sales, Repair, and Application Support:  
1675 Delany Rd.  
Gurnee, IL. 60031  
847-782-5288 Sales/Order Entry Fax  
847-782-5277 Applications Support Fax  
800-326-6216 Sales/Order Entry  
800-326-6216 Applications Support

## Partlow, West, Rustrak, and LFE Brands:

Sales, Repair, and Application Support:  
1675 Delany Rd.  
Gurnee, IL. 60031  
847-662-4150 Sales/Order Entry Fax  
847-782-5277 Applications Support Fax  
800-873-8731 Sales/Order Entry  
800-866-6659 Applications Support

Please disregard all phone numbers and addresses in this manual. The phone numbers and address on this page are the correct phone number and addresses to use for sales, repair, and application support.