

INSTRUCTIONS

for INSTALLATION, OPERATION and MAINTENANCE POWERSTAT® Variable Transformers of the 1156D, 1256D and 1296D series

Manufactured under one or more of the following U.S. Patents: 3,466,585; 3,529,348. Patented in Canada 1970.
Superior Electric reserves the right to make engineering refinements on all its products. Such refinements may affect information given in the instructions. Therefore, USE ONLY THE INSTRUCTIONS THAT ARE PACKED WITH THE PRODUCT.



INSTALLATION

PANEL MOUNTING

Manually-operated single units and 2- and 3-gang assemblies as supplied may be mounted on panels up to 1/2" (12.7mm) thick. For thicker panels, longer mounting bolts and shaft must be used as follows: Use 1/2-20 bolts about 9/8" (9.5mm) longer than the panel thickness plus washers. For the shaft, use 3/4" (19mm) O.D. bar stock or seamless tubing. The length should be the panel thickness plus 8-3/4" (222mm) for a single unit, 15-3/8" (391mm) for a 2-gang unit or 22" (559mm) for a 3-gang assembly.

To change a shaft, loosen the three setscrews in the hub of each deck and remove the original shaft. Mount the new shaft with the end flush with the hub of the bottom deck. On ganged units, it is very important that all the brushes be in proper alignment and track together. Therefore, rotate all the brushes to the extreme counterclockwise (low voltage) position before tightening the setscrews.

- Using the mounting template on the reverse side of these instructions, locate and drill the four mounting bolt holes, the four dial mounting screw holes and the center shaft hole. The four dial mounting screw holes must be tapped to accept the #6-32 screws provided.
- Remove the handwheel, dial and unit mounting screws from the unit. The dial standoffs are of no further use and may be discarded.
- Place the unit in position behind the panel. Insert and tighten the 1/2-20 mounting screws. On a 3-gang assembly, a cradle or other support should be provided for the end farthest from the panel.
- Mount the dial on the front of the panel. Place the handwheel on the shaft and position the pointer correctly with respect to the brush position and the dial indications. Tighten the setscrews in the hub of the handwheel.

WALL, BENCH AND FLOORING MOUNTING

Single, 2-gang and 3-gang units

Manual and motor-driven single units and 2- and 3-gang assemblies may be wall, bench or floor mounted in the following manner.

- Using the mounting template on the reverse side of these instructions, locate and drill the four mounting bolt holes. The dial screw holes and the center shaft hole are not needed.
- Place the unit in position and secure it with 1/2-20 bolts. When a 3-gang assembly is mounted on a vertical surface, additional support must be provided for the end opposite the mounting surface.

If it is desired that the mounting bolts not go completely through the supporting member (as when mounting with lag screws) the unit may be mounted on an adapter plate and the adapter plate may then be fastened in the desired position.

4-, 5-, 6-, 7-, 8- and 9-gang units

Manual and motor driven 4-, 5-, 6-, 7-, 8- and 9-gang units may be bench or floor mounted in the following manner.

- Drill the four mounting bolt holes as shown in Figure E.
- Place the unit in position and secure it with 1/2" bolts.

10-, 12-, 14-, 15-, 16-, 18-, 21-, 24- and 27-gang units

These units may be bench or floor mounted in the following manner.

- Drill the appropriate mounting holes as shown in Figure F for "PS" and "D" units or in Figure G for "Y" units.
- Place the unit in position and bolt it in place with 1/2" bolts.

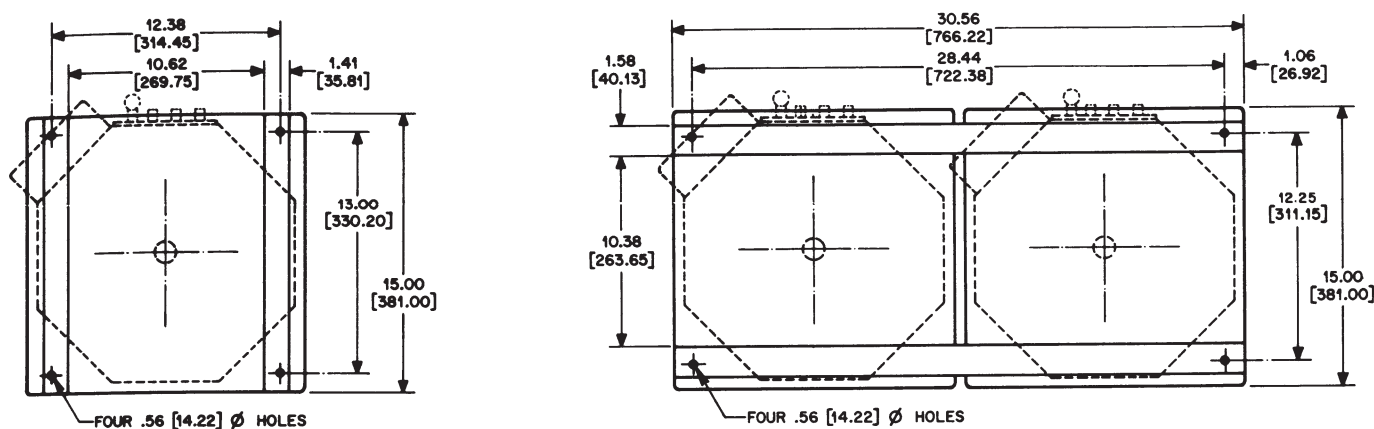

FIGURE E
4, 5, 6, 7, 8 and 9-gang units

FIGURE F
10D, 10PS, 12D, 12PS, 14D, 14PS, 16D, 16PS, 18D and 18PS Units

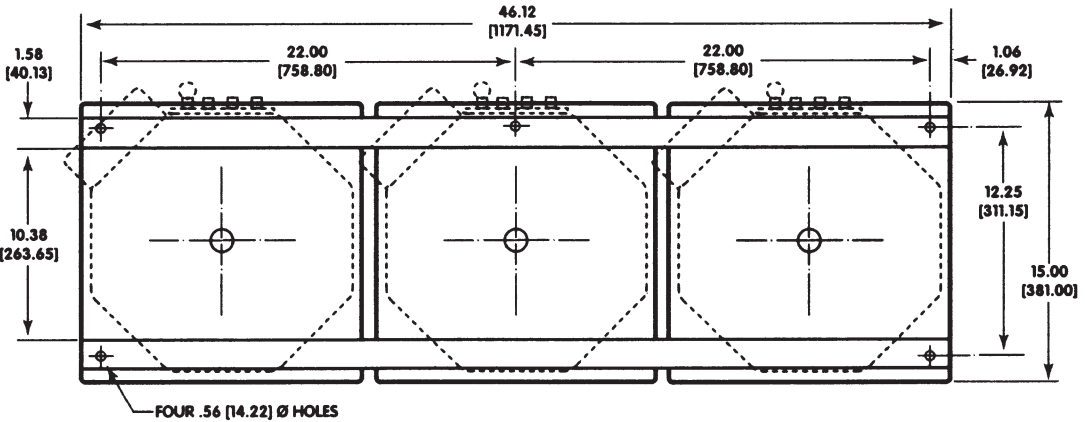

FIGURE G
12Y, 15Y, 18Y, 21Y, 24Y and 27Y Units

MAINTENANCE

With ordinary care and attention to the precautions outlined below, a POWERSTAT Variable Transformer will provide long, trouble-free service. The only elements that may require replacement are the brushes. They should be inspected periodically and replaced if arcing occurs or if they are badly worn. Do not replace them with ordinary brushes because they must be of a special material. They are also of a design which assures perfect contact of the brush to the commutator under proper pressure regardless of the brush position and length of time in use.

- Turn the shaft to the extreme counterclockwise (zero output voltage) position. Remove the section of the perforated protective screen to the left of the terminal panel by removing the two fastening screws. Unfasten the two brush assembly anchor screws. Remove and discard the old brushes.
- Insert the new brush assembly in the radiator slot, replace the anchor screws and tighten to the radiator. Be sure that the back end of the brush strap is under the projection at the rear of the brush slot in the radiator.
- Raise the brushes and place a piece of crocus cloth or very fine sandpaper between the commutator surface and the brushes so that the smooth side is against the commutator surface and the abrasive side is toward the brushes.
- Hold the crocus cloth or sandpaper tightly in place and rotate the radiate through a short arc. Blow out the excess carbon particles.
- Remove the cloth or sandpaper and rotate the radiator several times to check for smooth travel of the brushes over the commutator surface. The brushes should fit flat against the commutator over the full range from minimum voltage to maximum. No space should be visible between the brushes and the commutator surface.
- Replace the perforated screen and its fastening screws. The unit is ready for operation.

PRECAUTIONS

- Be absolutely certain that line voltage, phase and frequency are correct for the model.
- 250 volt fuses are supplied for the protection of the units. The fuse current ratings are 50 amperes for the 1156D series and 30 amperes for the 1256D series. The 1296D series is supplied with 600 volt, 40 ampere fuses.
- Provide an additional support for wall or back-of-panel mounted 3-gang units.
- Prevent the radiator from striking sharply against its stop, since this tends to weaken the entire structure of the unit.

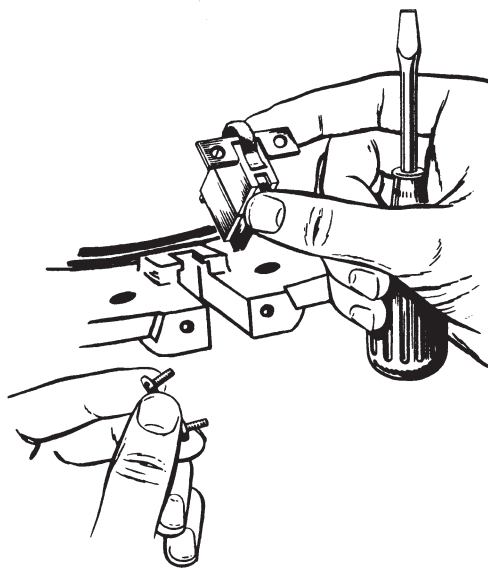

SERIES	BRUSH ASSEMBLY NUMBER
1156D	RB1156B
1256D	RB1256B
1296D	RB1296B

INSPECTION

When unpacking the unit, examine it carefully for any sign of shipping damage. The "Damage and Shortage" instruction packed with the unit outlines the procedure to follow if any parts are missing or damaged.

CONNECTIONS

GENERAL

Coil-to-terminal wiring is shown in Figure A for 1156D models and in Figure B for 1256D and 1296D series units. All models have fuses mounted on the terminal board and have terminals for either line or overvoltage connections. 1256D and 1296D series units also have terminals for low voltage input operation. Operation on low voltage input tap for models in the 1256D and 1296D series is shown in Figure C. All assemblies of ten or more units and smaller units with current ratings of 168 amperes or more have the external connection lugs mounted on separate terminal boards. These units are wired at the factory for standard overvoltage connection (i.e., maximum output voltage 17% above line voltage). Jumpers connecting these lugs to the unit terminals must be changed as shown in the connection diagram packed with the assembly to obtain different voltage ratings.

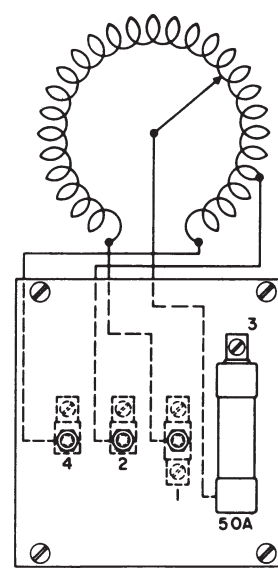

1156D
FIGURE A

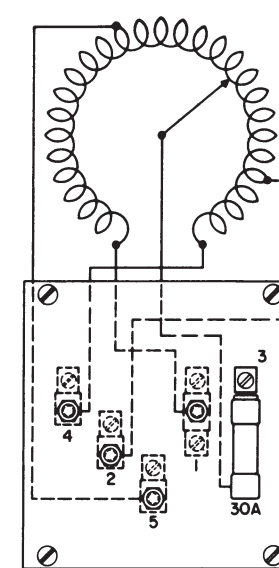

1256D, 1296D
FIGURE B

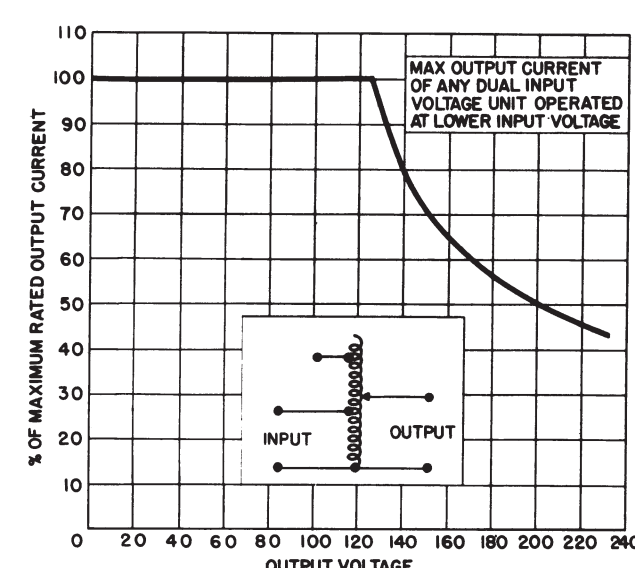

FIGURE C

MOTOR-DRIVE

Motor driven units have the same coil-to-terminal connections as the corresponding manually operated units. Wiring to the motor-drive for all models is shown in Figure D.

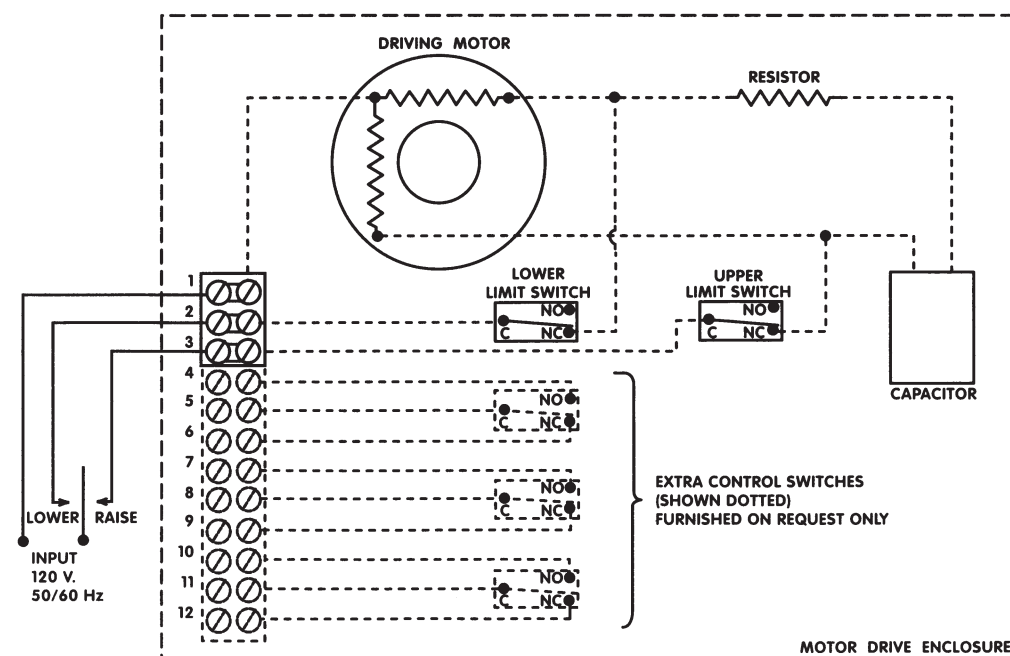
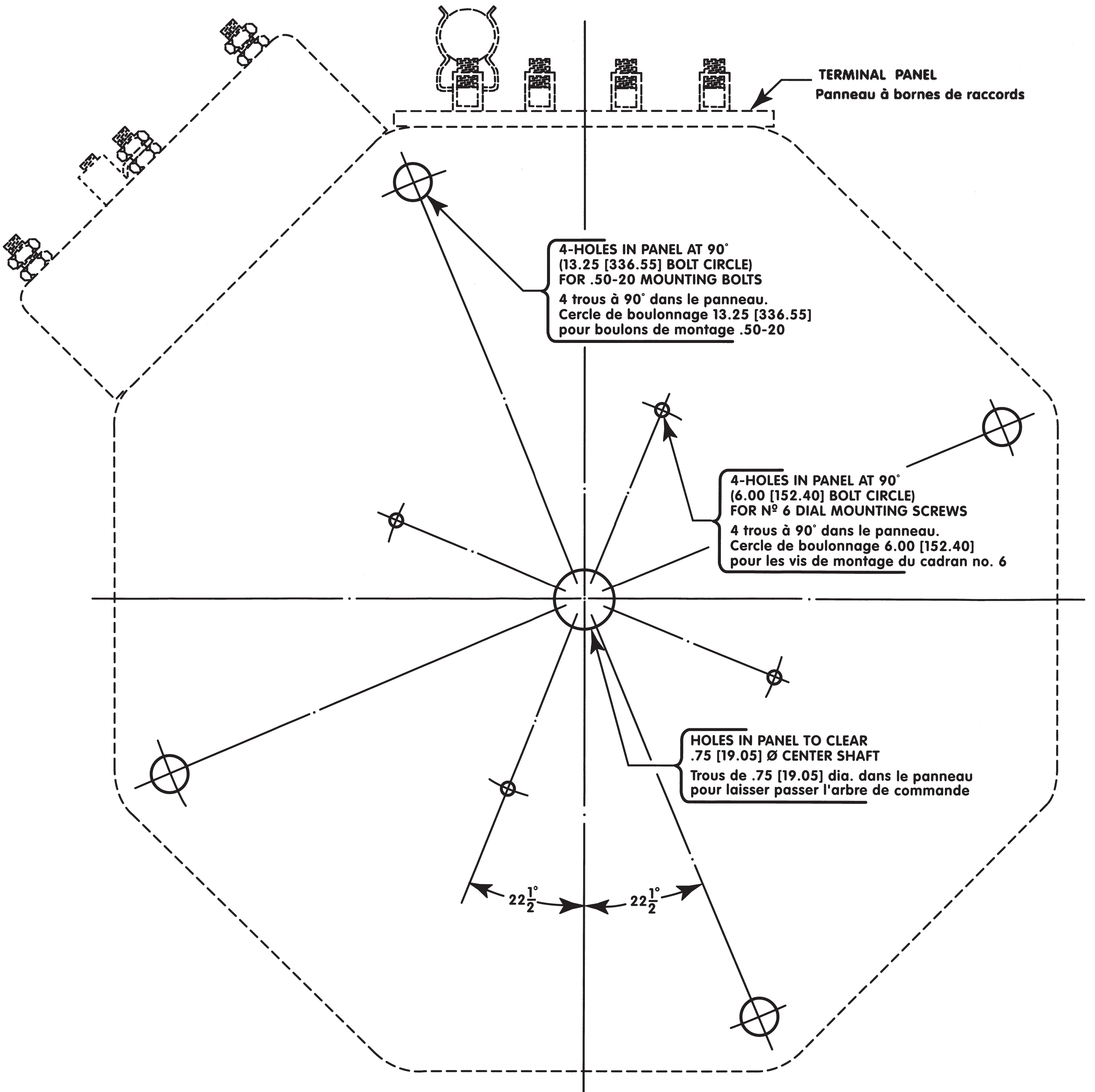

FIGURE D

TOP
Haut



TERMINAL PANEL
Panneau à bornes de raccords

4-HOLES IN PANEL AT 90°
(13.25 [336.55] BOLT CIRCLE)
FOR .50-20 MOUNTING BOLTS
4 trous à 90° dans le panneau.
Cercle de boulonnage 13.25 [336.55]
pour boulons de montage .50-20

4-HOLES IN PANEL AT 90°
(6.00 [152.40] BOLT CIRCLE)
FOR N° 6 DIAL MOUNTING SCREWS
4 trous à 90° dans le panneau.
Cercle de boulonnage 6.00 [152.40]
pour les vis de montage du cadran no. 6

HOLES IN PANEL TO CLEAR
.75 [19.05] Ø CENTER SHAFT
Trous de .75 [19.05] dia. dans le panneau
pour laisser passer l'arbre de commande

$22\frac{1}{2}^\circ$ $22\frac{1}{2}^\circ$

MOUNTING TEMPLATE
Gabarit montage