

# OPEN UP FOR: RATINGS CHART & CONNECTION DIAGRAMS

- CONNECTIONS AND RATINGS given in these instructions are those most commonly used. In addition, all ganged units may be connected so that the units operate electrically independent on a common shaft. When this is desired, connections and ratings for the individual units may be obtained from the RATINGS CHART and CONNECTION DIAGRAMS of the single unit.
- For ambient temperatures between -20°C and +50°C use current ratings given in the charts. Figure D shows the output current de-rating required above 50°C.
- Coil to terminal connections for all Q Series units are shown in Figures A, B and C.
- The connection diagrams are labeled "L" for Line Connections, "B" for Boost Connections and "S" for Step-Up Connections.
- For the Step-Up Connections, the Ratings Chart shows maximum output current rating for output voltages up to 125% of the input voltage, and maximum kVA at maximum output voltage. The output current must be reduced according to the curve in Figure E for output voltages greater than 125% of input voltage. Maximum kVA may be calculated using the rating curve in Figure E for voltages less than maximum.
- Clockwise (CW) and counter-clockwise (CCW) rotation connections shown in the Ratings Chart and Connection Diagrams are for units with the knob on the radiator end. For connections with the knob on the base end, use the shown CW connection for CW operation, and shown CCW connection for CCW operation.
- Fuses are recommended on all units as shown (S). Recommended fuses are 10 ampere on Q116U and Q117U, 4 ampere on Q216U and 5 ampere on Q217U. If used for constant impedance load connections the fuses can be increased to a 12 ampere on Q116U, 15 ampere on Q117U, 5 ampere on Q216U and 8 ampere on Q217U.
- COMMON shown in the Connection Diagrams is used as third leg in 3-phase open delta, or neutral in single-phase 3-wire and 3-phase 4-wire configurations. COMMON is not used in single-phase 2-wire or 3-phase 3-wire configurations. Jumper(s) provided in standard common position should be moved or removed as required.

**Important connection notes. Please read carefully.**

## CONNECTIONS AND RATINGS

Whenever unusual mechanical or electrical difficulties are encountered in the installation or operation of your POWERSTAT Variable Transformer, consult Superior Electric.

TYPE	PART NO.	DESCRIPTION
Q116U	065206-001	RBQ116
Q117U	065206-003	RBQ117
Q216U / Q217U	065206-002	RBQ216/RBQ217

## REPLACEMENT BRUSH ASSEMBLIES

When installed and operated in accordance with these instructions, a POWERSTAT Variable Transformer should require no servicing except possible replacement of the brush assembly. The brushes should be inspected periodically and replaced if they are badly worn. Use only the correct Superior Electric replacement brush assembly. The brushes must be of a special material if proper operation is to be attained.

## MAINTENANCE

# INSTRUCTIONS

for INSTALLATION OPERATION and MAINTENANCE

# POWERSTAT®

VARIABLE TRANSFORMERS  
WITH POWERKOTE® COILS

Q116U, Q117U, Q216U and Q217U Series

The right to make engineering refinements on all products is reserved. Dimensions and other details are subject to change.

## INSPECTION

A POWERSTAT Variable Transformer is a precision product packed with care. When unpacking, examine carefully for any shipping damage. Inspect the brush contact with particular care. The "Damage and Shortage" instructions packed with the unit outline the procedure to follow if any parts are damaged or missing.

### Telephone and Fax Numbers

Telephone 860-507-2025  
Fax 860-507-2050  
Customer Service 860-507-2025, Ext. 70782  
Product Application 860-507-2025, Ext. 72058

### Toll-Free (in USA and Canada only)

Telephone 1-800-787-3532  
Fax 1-800-821-1369  
Customer Service 1-800-787-3532, Ext. 70782  
Product Application 1-800-787-3532, Ext. 72058

Printed in USA



## Superior Electric

ONE COWLES ROAD • PLAINVILLE, CT 06062 USA

www.superiorelectric.com

002105-147 REV F

©2013 ECN 96882

## INSTALLATION

Units are designed for back-of-panel mounting. If they are to be bench or wall mounted, setscrews in the radiator slots can be loosened, permitting the shaft to be extended from the radiator end and some cover should be provided to support the dial and to prevent contact with the electrically "hot" radiator and commutator.

### Single Units

- 1 — Using the Mounting Template, locate and drill the four mounting holes "B", three dial mounting screw holes and the shaft hole. Maximum panel thickness is 3/4" inch.
- 2 — Secure the dial in place. Place the unit in position behind the panel and insert and fasten 1/4" mounting screws.
- 3 — Attach the knob with the pointer set at the correct position with respect to the brush location.

### Ganged Assemblies

- 1 — Using the Mounting Template, locate and drill the four mounting holes marked "B", the three dial mounting screw holes and the shaft hole. These units are provided with 1/4"-28 x 3/4" hex head screws for mounting in panels up to 1/2" thick. Longer 1/4"-28 screws must be provided for thicker panels. Panel thickness must not exceed 3/4". When a ganged assembly is mounted on a vertical panel, additional support should be provided for the back end of the unit and 1/4" studs on the base of the back unit of the assembly are provided for attaching to such supports.
- 2 — Secure the dial in place. Place the assembly in position behind the panel and insert and fasten the mounting screws into the standoffs.
- 3 — Attach the knob with the pointer set at the correct position with respect to the brush location.

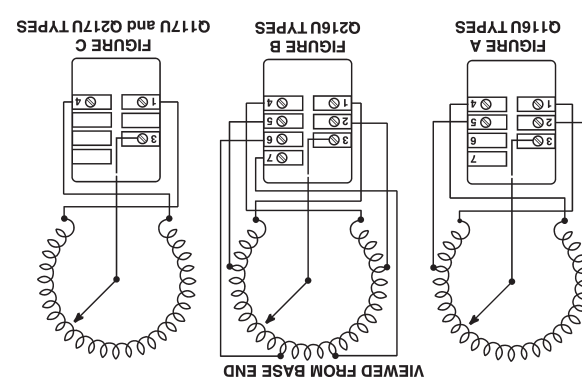
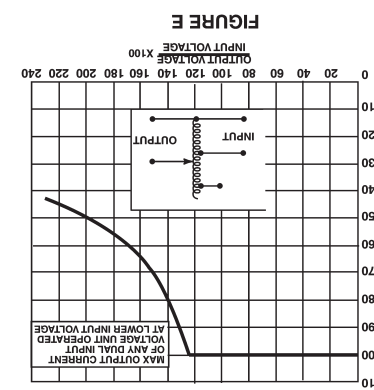
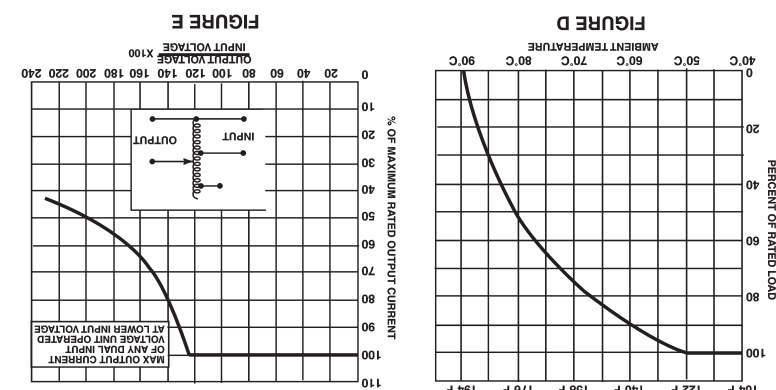

RATINGS CHART																									
120 VOLT, SINGLE PHASE																									
"LINE" CONNECTION						"BOOST" CONNECTION						"STEP-UP" CONNECTION													
Input Voltage:		120		0-120		120		0-140		N/A		120		0-140		N/A									
Output Voltage:		0-240		0-208		240		0-242		240		0-280		0-280		N/A									
Constant Current Load			Constant Impedance Load			Terminals & Rotation			Constant Current Load			Terminals & Rotation			Constant Current Load			Terminals & Rotation							
Freq. (Hz)	Max. Amps	Max. KVA	Max. Amps	Max. KVA	Max. Amps	Max. KVA	Input CW CCW	Output CW CCW	Jumper CW CCW	Freq. (Hz)	Max. Amps	Max. KVA	Input CW CCW	Output CW CCW	Jumper CW CCW	Freq. (Hz)	Max. Amps	Max. KVA	Input CW CCW	Output CW CCW	Jumper CW CCW	Model Numbers	Manually Operated	Motor Driven	Conn. Diag.
50/60	9	1.1	12	1.4	1.4	1.4	1-4 1-3	3-4		50/60	9	1.3	1-2 4-5	1-3 3-4								Q116U			1
60	10	1.2	13	1.6	1.4	1.4	1-4 1-3	3-4														Q117U			13

240 VOLT, SINGLE PHASE																									
"LINE" CONNECTION						"BOOST" CONNECTION						"STEP-UP" CONNECTION													
Input Voltage:		240		208		240		0-242		120		0-280		0-280		N/A									
Output Voltage:		0-480		0-380		240		0-242		240		0-280		0-280		N/A									
Constant Current Load			Constant Impedance Load			Terminals & Rotation			Constant Current Load			Terminals & Rotation			Constant Current Load			Terminals & Rotation							
Freq. (Hz)	Max. Amps	Max. KVA	Max. Amps	Max. KVA	Max. Amps	Max. KVA	Input CW CCW	Output CW CCW	Jumper CW CCW	Freq. (Hz)	Max. Amps	Max. KVA	Input CW CCW	Output CW CCW	Jumper CW CCW	Freq. (Hz)	Max. Amps	Max. KVA	Input CW CCW	Output CW CCW	Jumper CW CCW	Model Numbers	Manually Operated	Motor Driven	Conn. Diag.
50/60	3.5	0.84	5	1.2	1.4	1.4	1-4 1-3	3-4		50/60	3.5	0.98	1-2 4-5	1-3 3-4		50/60	3.5	0.42	1-6 4-7	1-3 3-4		Q216U			2
60	5	1.2	7	1.7	1.4	1.4	1-4 1-3	3-4														Q217U			13
50/60	9	2.2	12	2.9	4.4	4.4	1-1 3-3	1-1 3-3	1-1 4-4	50/60	9	2.5	2-2 5-5	3-3 3-3	1-1 4-4							Q116U-2			3
60	10	2.4	13	3.1	4.4	4.4	1-1 3-3	1-1 3-3	1-1 4-4													Q117U-2			14

480 VOLT, SINGLE PHASE																									
"LINE" CONNECTION						"BOOST" CONNECTION						"STEP-UP" CONNECTION													
Input Voltage:		480		380		480		0-560		240		0-560		0-485		N/A									
Output Voltage:		0-960		0-760		480		0-560		480		0-560		0-485		N/A									
Constant Current Load			Constant Impedance Load			Terminals & Rotation			Constant Current Load			Terminals & Rotation			Constant Current Load			Terminals & Rotation							
Freq. (Hz)	Max. Amps	Max. KVA	Max. Amps	Max. KVA	Max. Amps	Max. KVA	Input CW CCW	Output CW CCW	Jumper CW CCW	Freq. (Hz)	Max. Amps	Max. KVA	Input CW CCW	Output CW CCW	Jumper CW CCW	Freq. (Hz)	Max. Amps	Max. KVA	Input CW CCW	Output CW CCW	Jumper CW CCW	Model Numbers	Manually Operated	Motor Driven	Conn. Diag.
50/60	3.5	1.7	5	2.4	4.4	4.4	1-1 3-3	1-1 3-3	1-1 4-4	50/60	3.5	2.0	2-2 5-5	3-3 3-3	1-1 4-4	50/60	3.5	0.85	6-6 7-7	3-3 3-3	1-1 4-4	Q216U-2			4
60	5	2.4	7	3.4	4.4	4.4	1-1 3-3	1-1 3-3	1-1 4-4													Q217U-2			14

600 VOLT, SINGLE PHASE																									
"LINE" CONNECTION						"BOOST" CONNECTION						"STEP-UP" CONNECTION													
Input Voltage:		600		N/A		N/A		N/A		N/A		N/A		N/A		N/A									
Output Voltage:		0-600		N/A		N/A		N/A		N/A		N/A		N/A		N/A									
Constant Current Load			Constant Impedance Load			Terminals & Rotation			Constant Current Load			Terminals & Rotation			Constant Current Load			Terminals & Rotation							
Freq. (Hz)	Max. Amps	Max. KVA	Max. Amps	Max. KVA	Max. Amps	Max. KVA	Input CW CCW	Output CW CCW	Jumper CW CCW	Freq. (Hz)	Max. Amps	Max. KVA	Input CW CCW	Output CW CCW	Jumper CW CCW	Freq. (Hz)	Max. Amps	Max. KVA	Input CW CCW	Output CW CCW	Jumper CW CCW	Model Numbers	Manually Operated	Motor Driven	Conn. Diag.
60	3.5	2.1	5	3	4.4	4.4	1-1 3-3	1-1 3-3	1-1 4-4													Q216U-2			4

120 VOLT, THREE PHASE OPEN DELTA																									
"LINE" CONNECTION						"BOOST" CONNECTION						"STEP-UP" CONNECTION													
Input Voltage:		120		0-120		120		0-140		N/A		120		0-140		N/A									
Output Voltage:		0-240		0-208		240		0-242		240		0-280		0-280		N/A									
Constant Current Load			Constant Impedance Load			Terminals & Rotation			Constant Current Load			Terminals & Rotation			Constant Current Load			Terminals & Rotation							
Freq. (Hz)	Max. Amps	Max. KVA	Max. Amps	Max. KVA	Max. Amps	Max. KVA	Input CW CCW	Output CW CCW	Jumper CW CCW	Freq. (Hz)	Max. Amps	Max. KVA	Input CW CCW	Output CW CCW	Jumper CW CCW	Freq. (Hz)	Max. Amps	Max. KVA	Input CW CCW	Output CW CCW	Jumper CW CCW	Model Numbers	Manually Operated	Motor Driven	Conn. Diag.
50/60	9	1.9	12	2.5	4.4	4.4	1-1 3-3	1-1 3-3	1-1 4-4	50/60	9	2.2	2-1-2 5-4-5	3-1-3 3-4-3	1-1 4-4							Q116U-2			3
60	10	2.1	13	2.7	4.4	4.4	1-1 3-3	1-1 3-3	1-1 4-4													Q117U-2			14

240 VOLT, THREE PHASE OPEN DELTA																									
"LINE" CONNECTION						"BOOST" CONNECTION						"STEP-UP" CONNECTION													
Input Voltage:		240		208		240		0-280		120		0-280		0-280		N/A									
Output Voltage:		0-480		0-380		240		0-242		240		0-280		0-280		N/A									
Constant Current Load			Constant Impedance Load			Terminals & Rotation			Constant Current Load			Terminals & Rotation			Constant Current Load			Terminals & Rotation							
Freq. (Hz)	Max. Amps	Max. KVA	Max. Amps	Max. KVA	Max. Amps	Max. KVA	Input CW CCW	Output CW CCW	Jumper CW CCW	Freq. (Hz)	Max. Amps	Max. KVA	Input CW CCW	Output CW CCW	Jumper CW CCW	Freq. (Hz)	Max. Amps	Max. KVA	Input CW CCW	Output CW CCW	Jumper CW CCW	Model Numbers	Manually Operated	Motor Driven	Conn. Diag.
50/60	3.5	1.5	5	2.1	4.4	4.4	1-1 3-3	1-1 3-3	1-1 4-4	50/60	3.5	1.7	2-1-2 5-4-5	3-1-3 3-5-3	1-1 4-4	50/60	3.5	0.74	6-1-6 7-4-7	3-1-3 3-4-3	1-1 4-4	Q216U-2			4
60	5	2.1	7	2.9	4.4	4.4	1-1 3-3	1-1 3-3	1-1 4-4													Q217U-2			14

240Y/138 VOLT, THREE PHASE WYE																									
"LINE" CONNECTION						"BOOST" CONNECTION						"STEP-UP" CONNECTION													
Input Voltage:		240		208		240		0-280		120		0-280		0-280		N/A									
Output Voltage:		0-480		0-380		240		0-242		240		0-280		0-280		N/A									
Constant Current Load			Constant Impedance Load			Terminals & Rotation			Constant Current Load			Terminals & Rotation			Constant Current Load			Terminals & Rotation							
Freq. (Hz)	Max. Amps	Max. KVA	Max. Amps	Max. KVA	Max. Amps	Max. KVA	Input CW CCW	Output CW CCW	Jumper CW CCW	Freq. (Hz)	Max. Amps	Max. KVA	Input CW CCW	Output CW CCW	Jumper CW CCW	Freq. (Hz)	Max. Amps	Max. KVA	Input CW CCW	Output CW CCW	Jumper CW CCW	Model Numbers	Manually Operated	Motor Driven	Conn. Diag.
50/60	9	3.8	12	5	4.4	4.4	1-1 3-3	1-1 3-3	1-1 4-4	60	9	4.4	2-2-2 5-5-5	3-3-3 3-3-3	1-1 4-4							Q116U-3			5
60	10	4.2	13	5.4	4.4	4.4	1-1 3-3	1-1 3-3	1-1 4-4													Q117U-3			15

  

480Y/277 VOLT, THREE PHASE WYE																									
"LINE" CONNECTION						"BOOST" CONNECTION						"STEP-UP" CONNECTION													
Input Voltage:		480		380		480		0-560		240		0-560		0-485		N/A									
Output Voltage:		0-960		0-760		480		0-560		480		0-560		0-485		N/A									
Constant Current Load			Constant Impedance Load			Terminals & Rotation			Constant Current Load			Terminals & Rotation			Constant Current Load			Terminals & Rotation							
Freq. (Hz)	Max. Amps	Max. KVA	Max. Amps	Max. KVA	Max. Amps	Max. KVA	Input CW CCW	Output CW CCW	Jumper CW CCW	Freq. (Hz)	Max. Amps	Max. KVA	Input CW CCW	Output CW CCW	Jumper CW CCW	Freq. (Hz)	Max. Amps	Max. KVA	Input CW CCW	Output CW CCW	Jumper CW CCW	Model Numbers	Manually Operated	Motor Driven	Conn. Diag.
50/60	3.5	2.9	5	4.2	4.4	4.4	1-1 3-3	1-1 3-3	1-1 4-4	60	3.5	3.4	2-2-2 5-5-5	3-3-3 3-3-3	1-1 4-4	60	3.5	1.5	6-6-6 7-7-7	3-3-3 3-3-3	1-1 4-4	Q216U-3			6
60	5	4.2	7	5.8	4.4	4.4	1-1 3-3	1-1 3-3	1-1 4-4													Q217U-3			15

  

600Y/346 VOLT, THREE PHASE WYE																									
"LINE" CONNECTION						"BOOST" CONNECTION						"STEP-UP" CONNECTION													
Input Voltage:		600		N/A		N/A		N/A		N/A		N/A		N/A		N/A									
Output Voltage:		0-600		N/A		N/A		N/A		N/A		N/A		N/A		N/A									
Constant Current Load			Constant Impedance Load			Terminals & Rotation			Constant Current Load			Terminals & Rotation			Constant Current Load			Terminals & Rotation							
Freq. (Hz)	Max. Amps	Max. KVA	Max. Amps	Max. KVA	Max. Amps	Max. KVA	Input CW CCW	Output CW CCW	Jumper CW CCW	Freq. (Hz)	Max. Amps	Max. KVA	Input CW CCW	Output CW CCW	Jumper CW CCW	Freq. (Hz)	Max. Amps	Max. KVA	Input CW CCW	Output CW CCW	Jumper CW CCW	Model Numbers	Manually Operated	Motor Driven	Conn. Diag.
60	3.5	3.6	5	5.2	4.4	4.4	1-1 3-3	1-1 3-3	1-1 4-4													Q216U-3			6

### CONNECTION DIAGRAMS (Viewed from Radiator End)

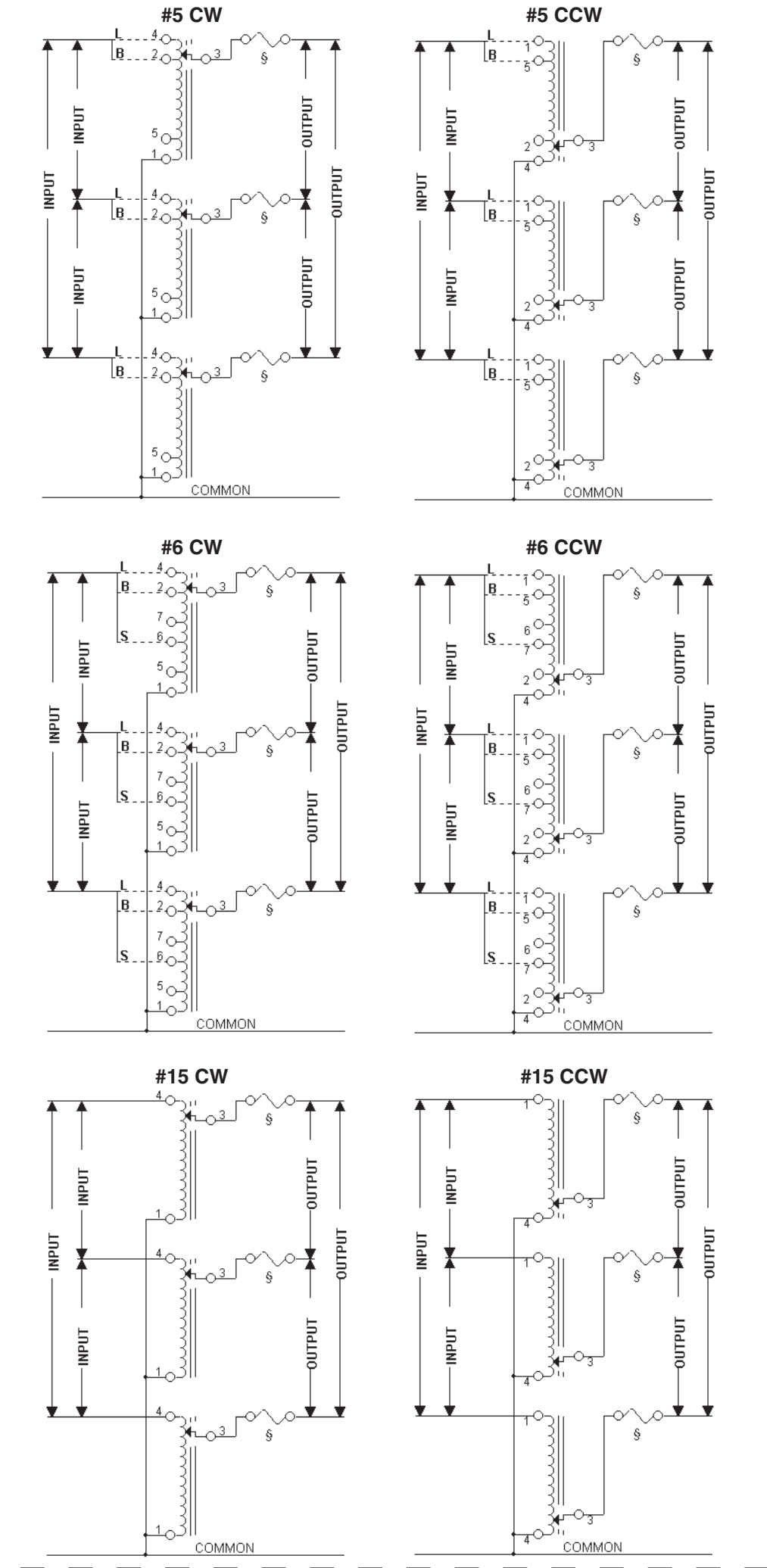
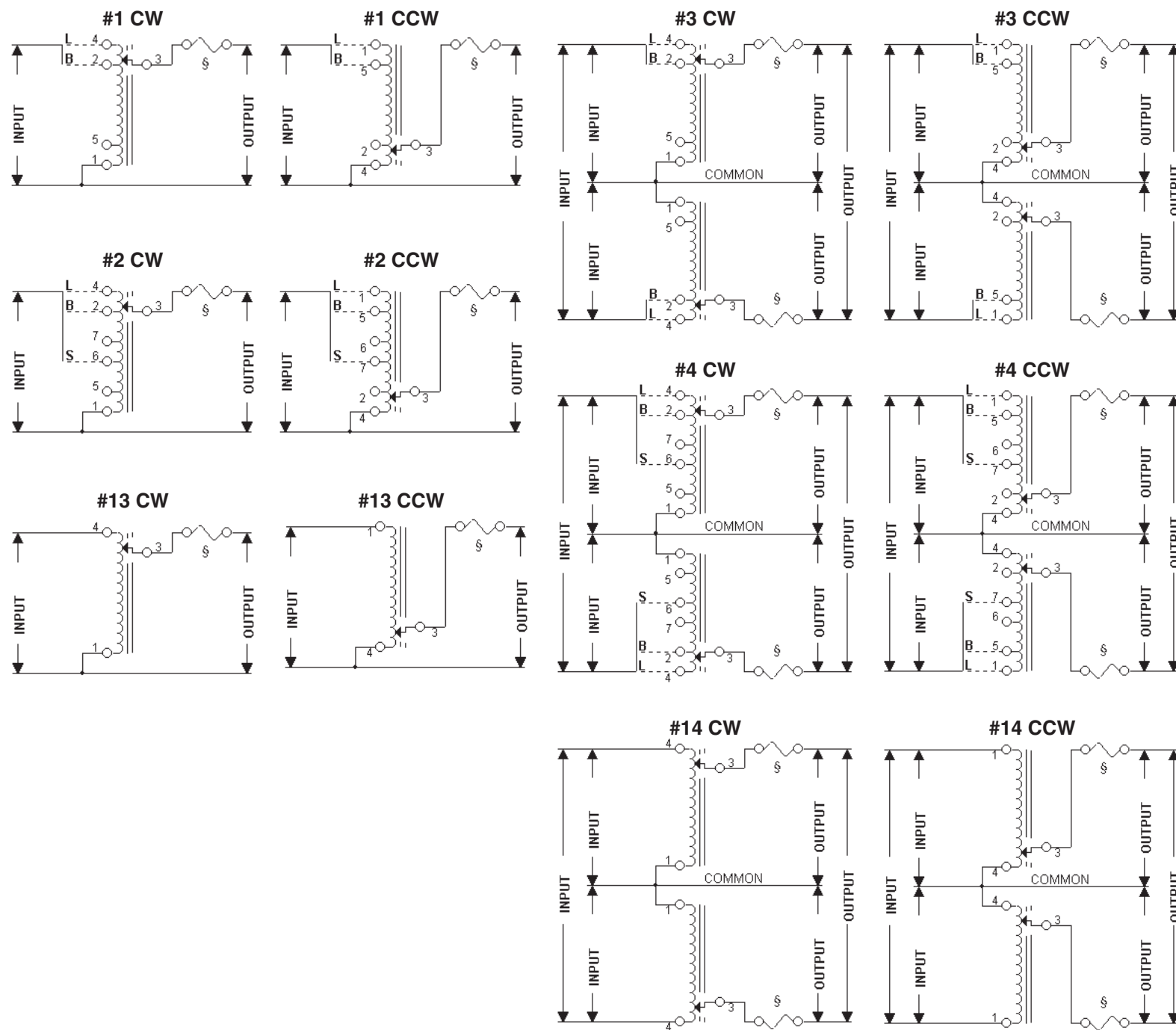

# Mounting Template

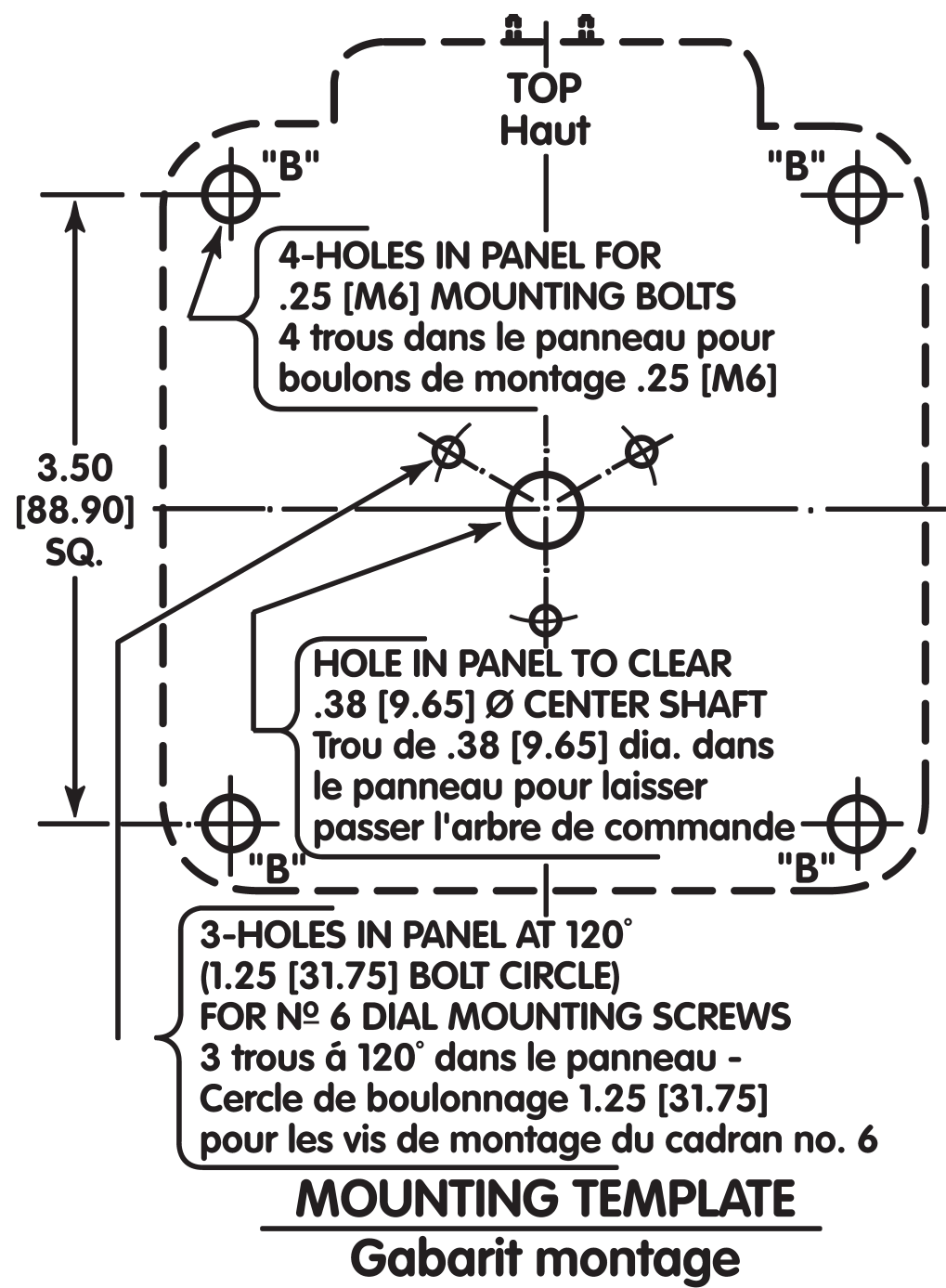

Detach at Perforation