

C628 Elapsed Timer

The Veeder-Root C628 Elapsed Timers are members of a family of 1/8 DIN instruments which offer breakthrough display technology as well as easy-to-program user setup. Its large LED display features the ability to change color based on process status such as exceeding a preset alarm value. Therefore, when monitoring an application's elapsed time, the C628 Elapsed Timer can provide operators with an instant visual alert to changes in the application's status.

The C628 Elapsed Timer has a definable set value at which an output will activate. The unit can be programmed to operate in a cumulative (elapsed time continues to accumulate during all instances when the input is active) or single (time value will display the elapsed time of an individual input and will reset to zero for each successive new pulse) input function mode. In addition, the time format (seconds, minutes, hours, minutes & seconds, or hours & minutes) and timing direction (up or down) can be selected.



- AWESOME 0.71" high digit LED display (27% larger than other 1/8 DIN units)
- Programmable color change display based on an event
- Programmable help function and secondary legend display
- Programmable for single input or cumulative operation
- Choice of NPN or PNP primary input
- Filter speed settable for 20, 200, or 10,000 Hz
- Standard Outputs: 1 NPN transistor & 1 relay
- Front panel reset enable and preset/alarm lockout
- CE approved, UL, CUL recognized



TIME



COUNT

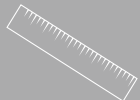

MEASURE

8:43

DISPLAY

ESVR1023-0001 Rev.A



C628 Elapsed Timer

SPECIFICATIONS

COUNT INPUTS	Sinking/Sourcing or Contact Closure Frequency: 10 kHz max. Logic Low 2.0 VDC; Logic High 3.0, 30V max. Impedance: 10 K to +Voltage - Sinking
CONTROL INPUTS	Sinking, Edge Sensitive Logic Low ≤ 2.0 VDC; Logic High ≥ 3.0 Impedance: 4.7 KΩ to +Voltage Response Time: 25 ms Functions: Input 1 - Remote Reset; Input 2 - Security Lockout
OUTPUTS	Solid State: NPN open collector, 30 VDC max., 100 mA max. Relay: SPDT, 2 resistive @ 110 VAC Latency: 75 seconds, plus 8 ms for relay pull-in
COMMUNICATION	Optional RS-485; Serial asynchronous, UART to UART; Open ASCII: One start bit, even parity seven data bits, one stop bit; Baud Rate selectable from 9600, 4800, 2400, or 1200 Maximum Zones: 99
SUPPLY VOLTAGE	90-264 VAC, 50/60 Hz, or 20-50 VAC/VDC; 4 Watts
ACCESSORY POWER SUPPLY	9-15 (unregulated VDC), 125 mA max.
DISPLAY	Red/Green, 7 segment LED Primary display: 5 digits, 0.71" (18mm) height Secondary display: single digit, 0.3" (7mm) height
TIME FORMATS	Seconds, Minutes, and Hours: XXX.X Minutes & Seconds and Hours & Minutes: XX.XX
DIMENSIONS	48mm x 96mm, 110mm deep
MOUNTING	Panel mount (mounting bracket supplied), 45mm x 92mm cutout
CONNECTIONS	Screw type terminals - combination head
FRONT PANEL RATING	NEMA 4X/IEC IP65
CASE MATERIAL	GE Lexan 940
WEIGHT	0.56 lbs.
OPERATING TEMPERATURE	0° to 55° Celsius, 32° to 131° Fahrenheit
STORAGE TEMPERATURE	-20° to 80° Celsius, -4° to 176° Fahrenheit
RELATIVE HUMIDITY	20% to 95% non-condensing
APPROVALS	CE; UL, CUL recognized

DIMENSIONS

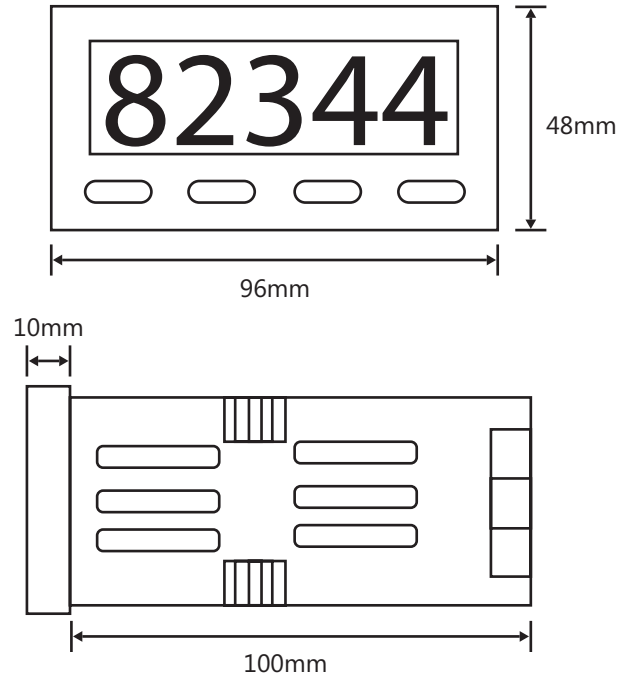

Panel Cutout: 45mm x 92mm (1.77: x 3.62")

ORDERING INFORMATION

C628 - 600 X X

Serial Communication Option
0 - None

Power Supply
0 - 90-264 VAC
2 - 20-50 VAC/VDC

Obsolete Parts

Optional RS-485 plug in card