

Dynapar brand Series HT50 Hand Tachometer

Technical Bulletin

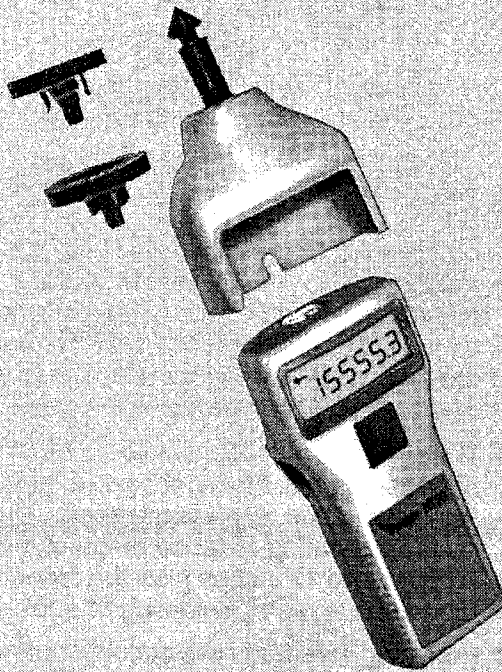

Bulletin Number: 701985-0000
For use with: HT50 01
Revision Level: None
Date: October 25, 1995

Danaher Controls
1675 Delany Road
Gurnee, IL 60031-1282
Phone: *708.662.2666
Fax: *708.662.6633

*Area Code changes to 847
during January 1996

Application Assistance
1.800.234.8731

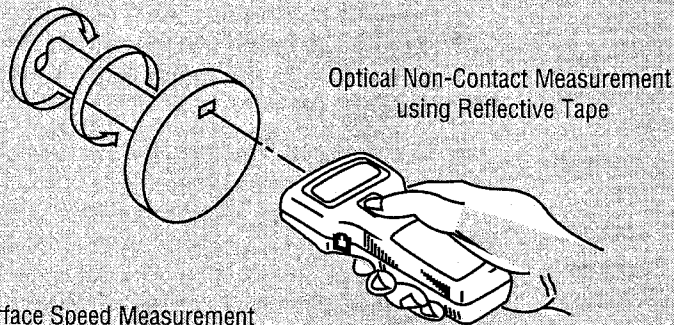

Surface Speed Measurement
using Adapter and Wheel

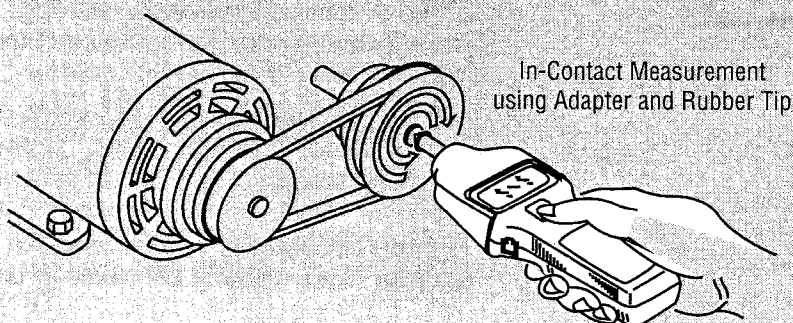
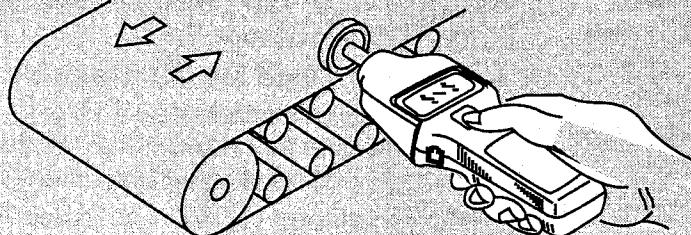

***Shirt-pocket size,
non-contacting or
in-contact... an
essential part of
every tool kit.***

- Optical non-contact or in-contact measurement
- Compact and lightweight
- Simple push button operation
- Automatic display hold and shutoff
- 30 to 30,000 RPM range with 0.1 resolution
- Complete kit – everything needed plus carry-case

The Veeder-Root brand Series HT50 hand tachometer provides a convenient, accurate means of measuring rotary or surface speeds on all types of machinery. For non-contacting measurement, the tachometer optically detects a reflective target on the rotating object to read revolutions per minute. Where in-contact measurement is desired, an accessory adaptor is used with the appropriate device – a wheel for surface speed or rubber tip for shaft rotation.

1. Package Contents

Before use, inspect HT50 package contents for presence of the following:

- 1 pc. Carrying Case
- 1 pc. HT50 Mainframe
- 1 pc. In-Contact Adaptor
- 1 pc. Yardage Measuring Wheel
- 1 pc. Meter Measuring Wheel
- 3 pc. Rubber Tip
- 4 pc. AAA Batteries **Alkaline batteries**
- 10 pc. Reflective Tape

2. Preparation

Prepare your HT50 for use as follows:

- a. Press down on the battery compartment cover and slide it off.
- b. Locate the slide-switch in the battery compartment. It should be set to the "ON" position for normal use of the HT50. *When the optional Remote Sensor accessory is used, the switch must be set to "OFF".*
- c. Install the four AAA batteries observing polarity as shown.
- d. Replace the cover.

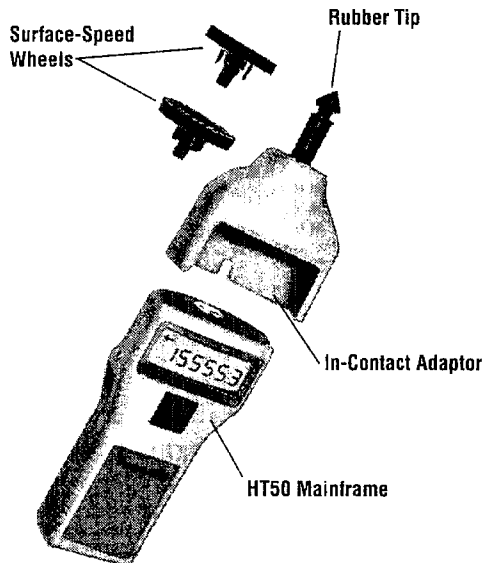

3. Reflective Mode RPM Measurements

Caution: Be sure machinery is turned off or otherwise disengaged during the placement of reflective tape.

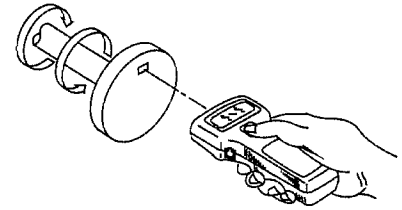

- a. Cut off a 1 to 2 inch (3 to 5 CM) length of the supplied reflective tape. Locate a spot on the shaft or object whose RPM is to be measured that will be "visible" to the tachometer's light beam. Clean this area so to be free of oil, grease, etc. Remove the protective backing from the cut length of tape and stick the tape on the shaft.
- b. With proper precautions while in presence of operating machinery observed, aim the front lens of the HT50 at the shaft. The normal operating distance range of the HT50 is 2 to 12 inches from the reflective tape at an angle of incidence of $\pm 30^\circ$.
- c. Press the measurement button, confirm that the " \leftarrow " indicator is present in the display window, then read the RPM.
- d. Release the button. As a convenience, the display will retain the reading for 3 minutes, then the tachometer automatically switches off.
- e. The optional Remote Sensor accessory may be used for optical RPM measurements in areas that are unaccessible for normal aiming and reading. Connect the sensor's cable to the receptacle provided on the HT50's side surface. The switch in the unit's battery compartment must be placed in the "OFF" position. Refer to the procedure in Section 2.

4. In-Contact Mode Measurements

Operation requires the installation of the In-Contact Adaptor and rubber tip or surface speed wheels that are supplied as standard accessories.

- a. Loosen or remove the adaptor locking screw (located on the rear surface of the HT50).
- b. Slide the in-contact adaptor into place over the front of the HT50 mainframe. Tighten the locking screw using a coin or screwdriver.

Tighten securely to ensure that the adaptor does not slip off when in use.

5. In-Contact RPM Measurement

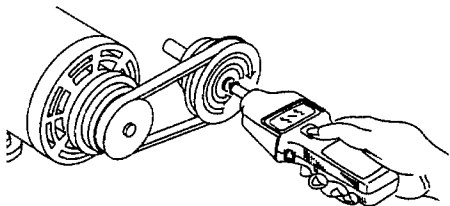

- Fully seat the rubber tip in the cavity provided in the adaptor's shaft.
- Take RPM reading by touching shaft center with rubber tip and pressing the HT50's measurement button.

Caution: Take extreme care when making in-contact measurements on operating machinery.

- Release the button. As a convenience, the display will retain the reading for 3 minutes, then the tachometer automatically switches off.

6. In-Contact Surface Speed Measurement

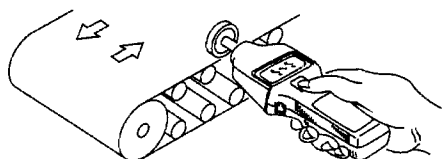

- If necessary, remove the rubber RPM tip from the adaptor's shaft. Position the yardage or metric measuring wheel so that its alignment tabs engage the slots provided in the adaptor's shaft.
- Firmly press the wheel until it is fully engaged and locked. This is evidenced by a noticeable click. Pull gently on the wheel to confirm that it is locked in place.
- The surface speed measurement should be made with the wheel touching the belt, roll, etc., so that it turns in parallel with the material's surface motion.

Caution: Take extreme care when making in-contact measurements on operating machinery.

- Pressing the HT50's measurement button will provide a reading of the measuring wheel's RPM. To determine the correct surface speed, multiply the reading by 1/10. For example, a reading of 1234.5 RPM using the yardage wheel converts to 123.45 yards/minute.
- Release the button. As a convenience, the display will retain the reading for 3 minutes, then the tachometer automatically switches off.

7. Battery Replacement

The display indicator "  " appears when it is time to replace the batteries. Use fresh AAA batteries that are all of the same type. Refer to section 2. for the installation procedure.

8. Replacement Parts

The following replacement parts may be ordered as required:

Description	Part. Number
Reflective Tape (10 sheets)	616483-001
Rubber RPM Tip (pkg 3)	576008-394
Wheel, 1/10 Yard	576008-395
Wheel, 1/10 Meter	576008-396
Remote Sensor	605830-0001
Replacement Adapter	605831-0001

9. Storage

If the HT50 is to be unused for long periods of time, batteries should be removed.

- Do not store in areas subject to high temperature or humidity.
- Avoid storage areas where the unit will be exposed to dust, dirt, saline material, corrosive environment, or high vibration.

10. Specifications

Measurement Range: 30.0 to 30,000 RPM;
3.00 to 3000.00 meters or yards per minute
using in-contact adapter and appropriate wheel

Resolution: 0.1 RPM

Accuracy: RPM: $\pm 0.01\%$, Surface Speed: $\pm 0.05\%$; and ± 1 digit

Optical Range: 50 to 300 mm (2 to 12 inches)
using reflective tape

Update Time: 1 to 2 seconds sample time

Display: 6 digit LCD; low battery and reflective light input indicators

Display Hold: 3 minutes from last measurement then auto power-off

Power Requirements: (4) 1.5V batteries, AAA size, included. 20 hours continuous measurement **Alkaline batteries**

Operating Temperature: 40° to +104°F (5° to +40°C)

Warranty

Standard products manufactured by the Company are warranted to be free from defects in workmanship and material for a period of one year from the date of shipment, and products which are defective in workmanship or material will be repaired or replaced, at the option of the Company, at no charge to the Buyer. Final determination as to whether a product is actually defective rests with the Company. The obligation of the Company hereunder shall be limited solely to repair and replacement of products that fall within the foregoing limitations, and shall be conditioned upon receipt by the Company of written notice of any alleged defects or deficiency promptly after discovery within the warranty period, and in the case of components or units purchased by the Company, the obligation of the Company shall not exceed the settlement that the Company is able to obtain from the supplier thereof. No products shall be returned to the Company without its prior consent. Products which the Company consents to have returned shall be shipped F.O.B. the Company's factory. The Company cannot assume responsibility or accept invoices for unauthorized repairs to its components, even though defective. The life of the products of the Company depends, to a large extent, upon the type of usage thereof, and THE COMPANY MAKES NO WARRANTY AS TO FITNESS OF ITS PRODUCTS FOR SPECIFIC APPLICATIONS BY THE BUYER NOR AS TO PERIOD OF SERVICE UNLESS THE COMPANY SPECIFICALLY AGREES OTHERWISE IN WRITING AFTER THE PROPOSED USAGE HAS BEEN MADE KNOWN TO IT.

THE FOREGOING WARRANTY IS EXCLUSIVE AND IN LIEU OF ALL OTHER WARRANTIES EXPRESSED OR IMPLIED, INCLUDING, BUT NOT LIMITED TO ANY WARRANTY OF MERCHANTABILITY OR OF FITNESS FOR A PARTICULAR PURPOSE.

Danaher Controls
1675 Delany Road
Gurnee, IL 60031-1282
Phone: *708.662.2666
Fax: *708.662.6633

E-Mail: dancon@dancon.com

Bulletin Number: 701985-0000
Revision Level: None
Date: October 25, 1995

*Area Code changes to 847
during January 1996

Printed in Japan