

IOM

MPR180213 Rev. B



MP Series Radar Transmitter Installation & Operation Manual



MP Series Radar Transmitter Installation & Operation Manual

CONTENTS

I. HANDLING AND STORAGE	1
Inspection and Handling	
Disposal and Recycling	
Storage	
II. GENERAL SAFETY	2
Authorized Personnel	
Use	
Misuse	
III. PRODUCT DESCRIPTION	3
Function	
Technical Specifications	
IV. MECHANICAL INSTALLATION	4
Guidelines	
Mounting Considerations	
V. ELECTRICAL INSTALLATION	7
General Safety	
Disconnect Requirements For Permanently Installed Equipment	
Wiring	
VI. SET UP	9
LCD Adjustment Unit	
Tank Parameters Reference	
Setting Parameters	
Measurement Span	
Dampening	
Current Output	
Echo Learning of False Echo	
Reset	
Current Output Test	
Full Menu Structure	
VII. MAINTENANCE	19
Every 6 months:	
Every 12 months:	
VIII. TROUBLESHOOTING	20

SAFETY SYMBOLS



WARNING:

IDENTIFIES CONDITIONS OR PROCEDURES, WHICH IF NOT FOLLOWED, COULD RESULT IN SERIOUS INJURY. RISK OF ELECTRICAL SHOCK.



CAUTION:

IDENTIFIES CONDITIONS OR PROCEDURES, WHICH IF NOT FOLLOWED, COULD RESULT IN SERIOUS DAMAGE OR FAILURE OF THE EQUIPMENT.

MP Series Radar Transmitter Installation & Operation Manual

I. HANDLING AND STORAGE

SAVE THESE INSTRUCTIONS

INSPECTION AND HANDLING

Do not dispose of the carton or packing materials.

Each package should be inspected upon receipt for damage that may have occurred due to mishandling during shipping. If the unit is received damaged, notify the carrier or the factory for instructions. Failure to do so may void your warranty. If you have any problems or questions, consult Customer Support at 800-778-9242.

DISPOSAL AND RECYCLING

This product can be recycled by specialized companies and must not be disposed of in a municipal collection site. If you do not have the means to dispose of properly, please contact for return and disposal instructions or options.

STORAGE

If the device is not scheduled for immediate installation following delivery, the following steps should be observed:

1. Following inspection, repackage the unit into its original packaging.
2. Select a clean dry site, free of vibration, shock and impact hazards.
3. If storage will be extended longer than 30 days, the unit must be stored at temperatures between 32° and 158° F (0° to 70° C) in non-condensing atmosphere with humidity less than 85%.



CAUTION: DO NOT STORE A NON-POWERED UNIT OUTDOORS FOR A PROLONGED PERIOD.

II. GENERAL SAFETY

AUTHORIZED PERSONNEL

All instructions described in the document must be performed by authorized and qualified service personnel only. Before installing the unit, please read these instructions and familiarize yourself with the requirements and functions of the device. The required personal protective equipment must always be worn when servicing this device.

USE

The device is solely intended for use as described in this manual. Reliable operation is ensured only if the instrument is used according to the specifications described in this document. For safety and warranty reasons, use of accessory equipment not recommended by the manufacturer or modification of this device is explicitly forbidden. All servicing of this equipment must be performed by qualified service personnel only. This device should be mounted in locations where it will not be subject to tampering by unauthorized personnel.

MISUSE

Improper use or installation of this device may cause the following:

- Personal injury or harm
- Application specific hazards such as vessel overfill
- Damage to the device or system

If any questions or problems arise during installation of this equipment, please contact Customer Support at 800-778-9242.

III. PRODUCT DESCRIPTION

FUNCTION

The MP Series meter measures the level of bulk solids in the storage vessels without physical contact to the level meter transmits microwaves at constant intervals and receives echoes (reflection of transmitted waves) from the surface of the material under measurement. The time difference between the transmission and reception of the microwave is processed by microcomputer to accurately determine the level of stored materials.

TECHNICAL SPECIFICATIONS

FUNCTIONAL	
Antenna	Horn
Power Supply	20 to 32 VDC
Power consumption	Max. 704 mW
Mounting	Swivel Flange
Dead Zone	11.8 in (30 cm) below the antenna
Max Measurable Distance	230 ft (70 m)
Transmitting frequency	26 GHz
Transmitting cycle	Every 83 ms
Beam angle (-3 dB)	Approx. 8° degrees
Resolution	1 mm
Allowable Fluctuation Rate	10 cm/s
PERFORMANCE	
Accuracy	± 1.2 in. or 0.04% of span, whichever is greater
Ambient Temp	Housing: -40° to 140° F (-40 to + 60° C); With LCD: -4° to 140° F (-20 to + 60° C). Note: 1 hour warm-up operation required at -40° F (-40° C) Antenna: -40° to 302° F (-40° to 150° C)
Pressure	Horn/Transducer (Max): 145 PSI (1 MPa) Swivel Mount Leakage (Max): 1.5 PSI (10k Pa)
Output signal	4 to 20mA x 1 (Resistive load Max. 499Ω), HART
Integral time	0-999s
PHYSICAL	
Material	Housing: Aluminum Antenna: 316 Stainless Steel
Protection	Housing: IP66 (Housing cover and lead outlet must be closed) Antenna: IP67
Conduit Entry	1 - G ¹ / ₂
Mass	Approx. 13 lb (6.0 kg)

IV. MECHANICAL INSTALLATION



WARNING: REMOVE POWER FROM THE UNIT BEFORE INSTALLING, REMOVING, OR MAKING ADJUSTMENTS.

GUIDELINES

- The measurement range and accuracy are guaranteed only when the antenna is pointed at an angle perpendicular to the material surface, and there is no presence of airborne dust, vapor, and agitated foam. If these conditions are not satisfied, the measurement range and accuracy may differ according to the measurement conditions.
- Ensure that freezing and/or condensing will not occur inside the electronic unit.
- If the cable gland is not tightened or loosens, water may enter and damage the equipment. When the equipment operates in the presence of process gases and/or fluids (especially corrosive gases those materials may penetrate through the resin of the cone antenna and damage the equipment.
- Cable size: AWG 22 to 16 in (0.3 mm² to 1.25 mm²)
- If the material could enter the dead zone, a stand pipe can be used to ensure that the material surface cannot reach the dead zone of the level meter.
- Mounting flange will mount to 150# ANSI type.
- Recommended height of stand pipe: the end of the horn antenna must be protruded a minimum of 0.4 in. (10 mm) from the stand pipe or the unit will not function properly. Avoid too long of a stand pipe to prevent malfunction of the instrument.

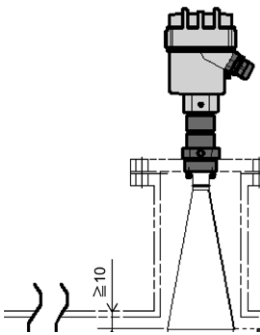

- Set the value of 100% (20 mA) level so that the dead zone is included. Setting the 100% (20 mA) level within the blind sector will cause a malfunction of the instrument.

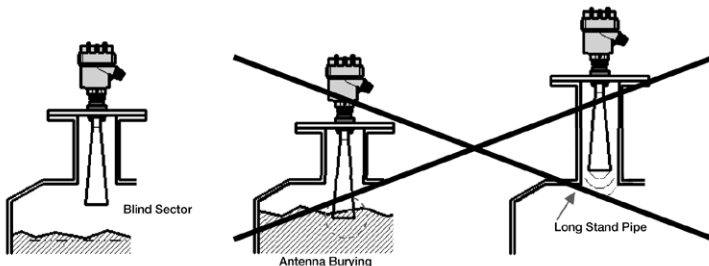

- Do not install the sensor close to the material fill pipe.
- Do not install any interfering instruments within the beam angle because reflections from beams, pipes, and other supports within the tank will cause false echoes.

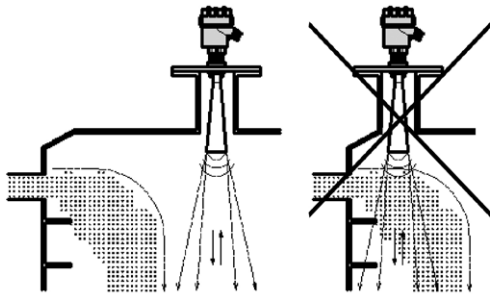

- The sensor may need to be re-aimed if false echo mapping does not work.
- Install protection such as a simple roof above the level meter to avoid exposure to direct sunlight.

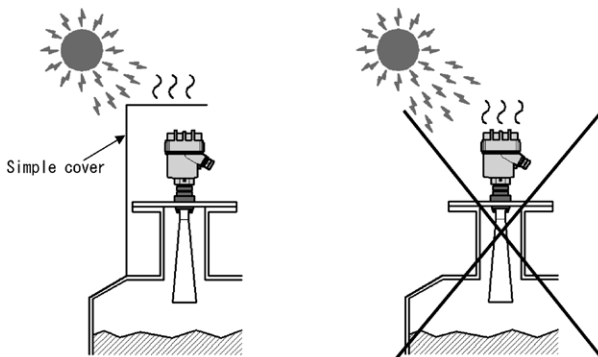

INSTALLATION

1. Determine where the unit will be installed.
2. Orient the unit so that the index mark is facing toward the center of the vessel.
3. Attach the unit to the vessel using the mounting plate or process fitting.
4. For the swivel flange only, direct the unit into the vessel. Unit should be aimed toward the center/gate of the vessel. Tighten bolts to the flange.

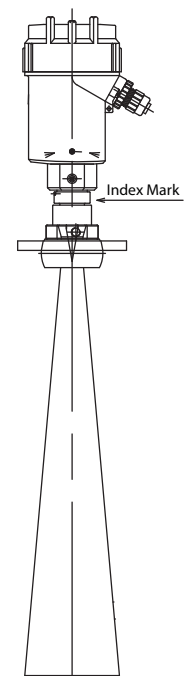

AIR PURGE

All units come standard with an air purge line, and should be used to keep the inside of the antenna clean. The air purge fitting size is G1/8. Please consult the factory for installation guidelines.

V. ELECTRICAL INSTALLATION



WARNING: REMOVE POWER FROM THE UNIT BEFORE INSTALLING, REMOVING, OR MAKING ADJUSTMENTS

GENERAL SAFETY

When using electrical equipment, you should always follow basic safety precautions, including the following:

- The installation and wiring of this product must comply with all national, federal, state, municipal, and local codes that apply.
- Properly ground the enclosure to an adequate earth ground.
- Do not modify any factory wiring. Connections should only be made to the terminals described in this section.
- All connections to the unit must use conductors with an insulation rating of 300 V minimum, rated for 212° F (105° C), a minimum flammability rating of VW-1, and be of appropriate gauge for the voltage and current required (see specifications).
- Do not allow moisture to enter the electronics enclosure. Conduit should slope downward from the unit housing. Install drip loops and seal conduit with silicone rubber product.

DISCONNECT REQUIREMENTS FOR PERMANENTLY INSTALLED EQUIPMENT

A dedicated disconnecting device (circuit breaker) must be provided for the proper installation of the unit. If independent circuits are used for power input and main relay outputs, individual disconnects are required.

Disconnects must meet the following requirements:

- Located in close proximity to the device
- Easily accessible to the operator
- Appropriately marked as the disconnect for the device and associated circuit
- Sized appropriately to the requirements of the protected circuit (see specifications)



WARNING: DO WIRING WHEN THE INSTRUMENT IS POWERED OFF. AVOID SHORT CIRCUIT AND REVERSE POLARITY.



CAUTION: THE UNIT MUST BE SUPPLIED WITH A DC POWER SUPPLY.

WIRING

1. Unscrew the cover. (rotate counterclockwise)
2. LCD unit is attached, remove it. (Rotate counterclockwise or to OPEN)
3. Open the wire entry of terminal block by pushing on the actuating lever with a flat screwdriver
4. Insert wires as shown on the panel (positive (+) to terminal entry No. 1 and negative (-) to terminal No. 2)
5. Release actuating lever of the terminal
6. Connect the ground wire to internal earth ground terminal (D-Class grounding).
7. Attach the LCD unit if it had been installed
8. Screw the cover on tightly
9. Connect ground screw (D-Class grounding) between conduit entry to tank or any other earth ground.



CAUTION: DO NOT CONNECT CABLE SHIELD WIRE ON DEVICE RECEIVING 4-20mA SIGNAL.

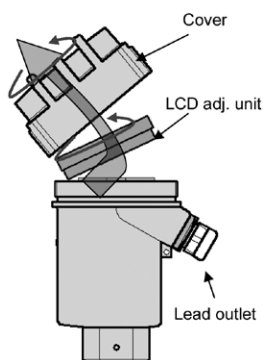

The LCD Adjustment Unit removed

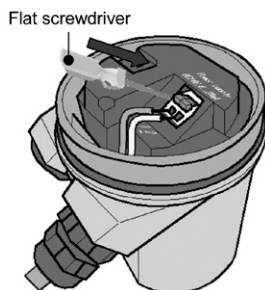

Do not touch the LCD Adjustment Unit connection terminal while instrument is powered on.

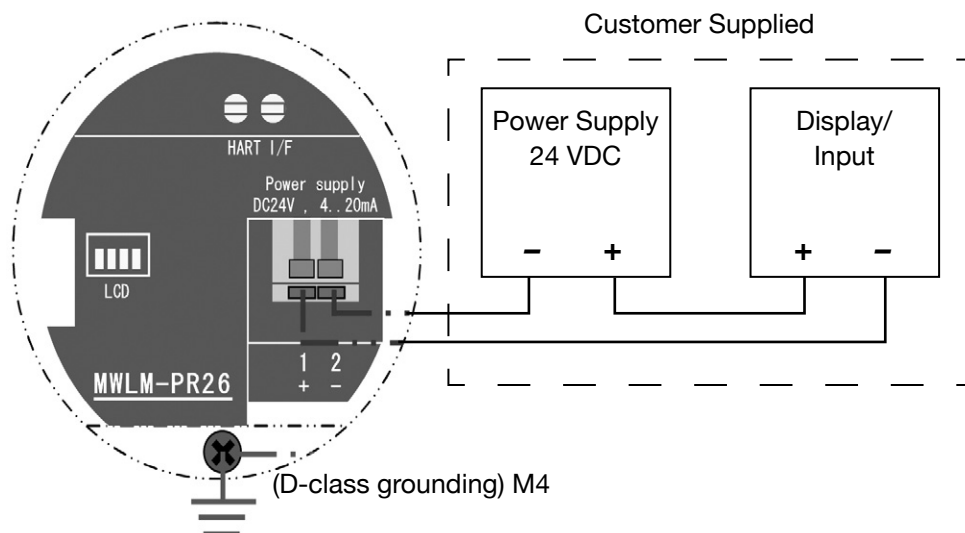

VI. SET UP

LCD ADJUSTMENT UNIT

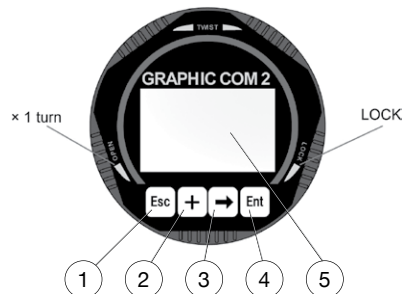

NO.	KEY	FUNCTION
1	Esc	<ul style="list-style-type: none"> Interrupt entry (cancel) Returns to previous screen
2	+	<ul style="list-style-type: none"> Moves cursor Change value Change Y axis (reflection) of waveform
3	→	<ul style="list-style-type: none"> Moves cursor to the left Change X-axis (distance) of waveform
4	Ent	<ul style="list-style-type: none"> Enters to menu Accepts value Shifts to next screen
5	Display	Displays parameters and waveforms

TANK PARAMETERS REFERENCE

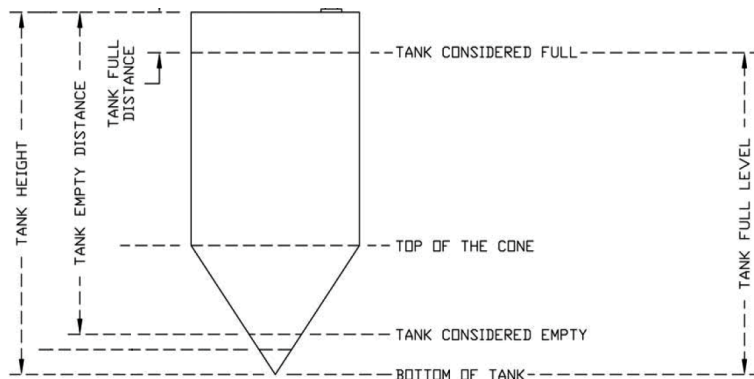

SETTING PARAMETERS

It is recommended that the following characteristics are determined before programming. The chart below can be used as reference, add more columns as necessary.

Sensor Address						
Sensor Name						
Units (Check one per sensor)	Distance	Feet				
		Meters				
Type Parameters		Tank Height				
		Full Distance				
		Empty Distance				

MEASUREMENT SPAN

Sets measurement span corresponding to the process level of 100% and 0%. Distance from level meter measuring reference point to material surface. Percent is equal to the amount of current at each level. 100% cannot be zero; must be set to least 11.8 in. (30 cm).

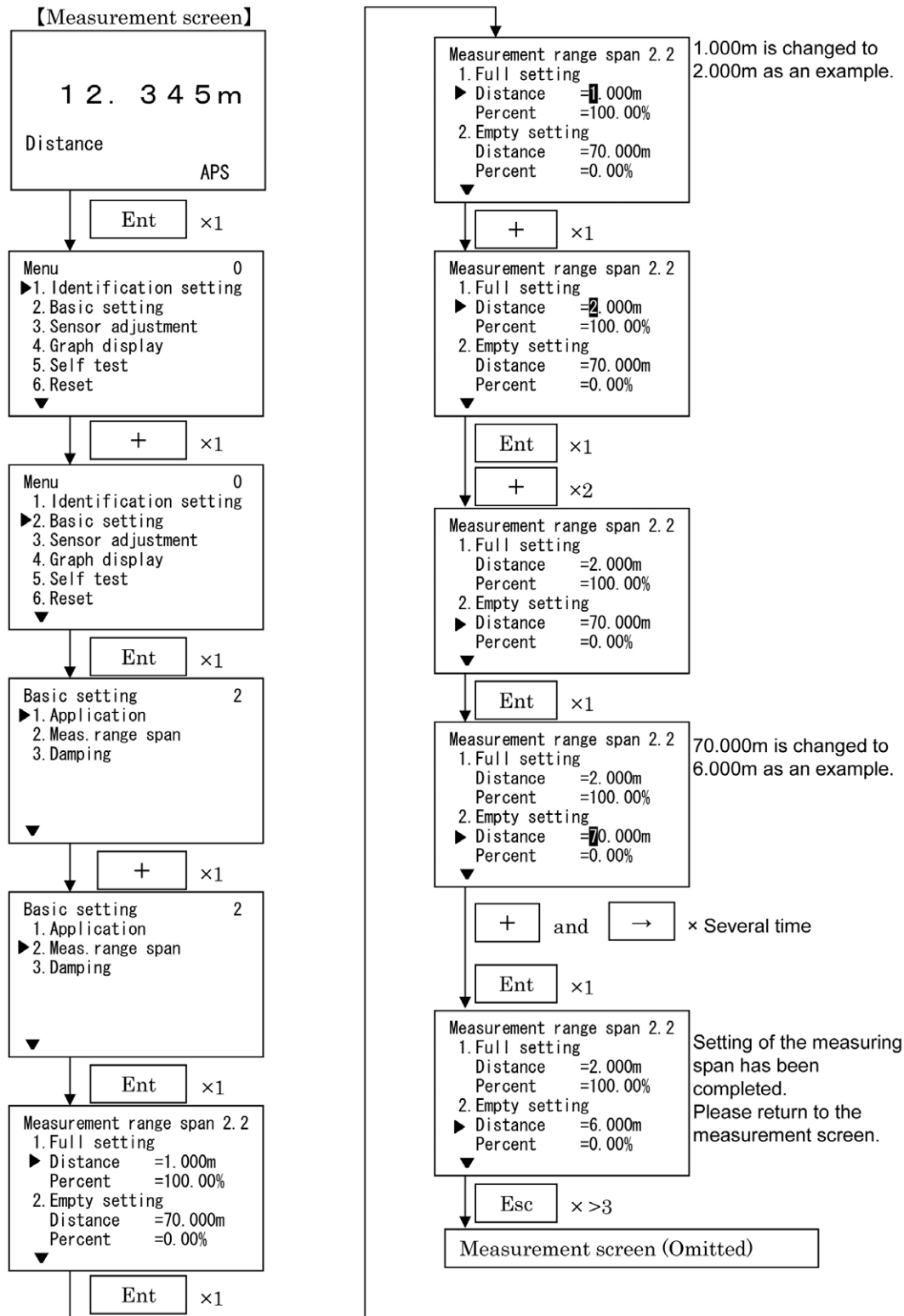

DAMPENING

Set the duration for the damping filter. The damping filter will smooth the response of a sudden change in the level. The time can be set between 0 and 999 seconds. Keep in mind that the update time of the display and output will be longer, but the sensor will react to changes with a delay.

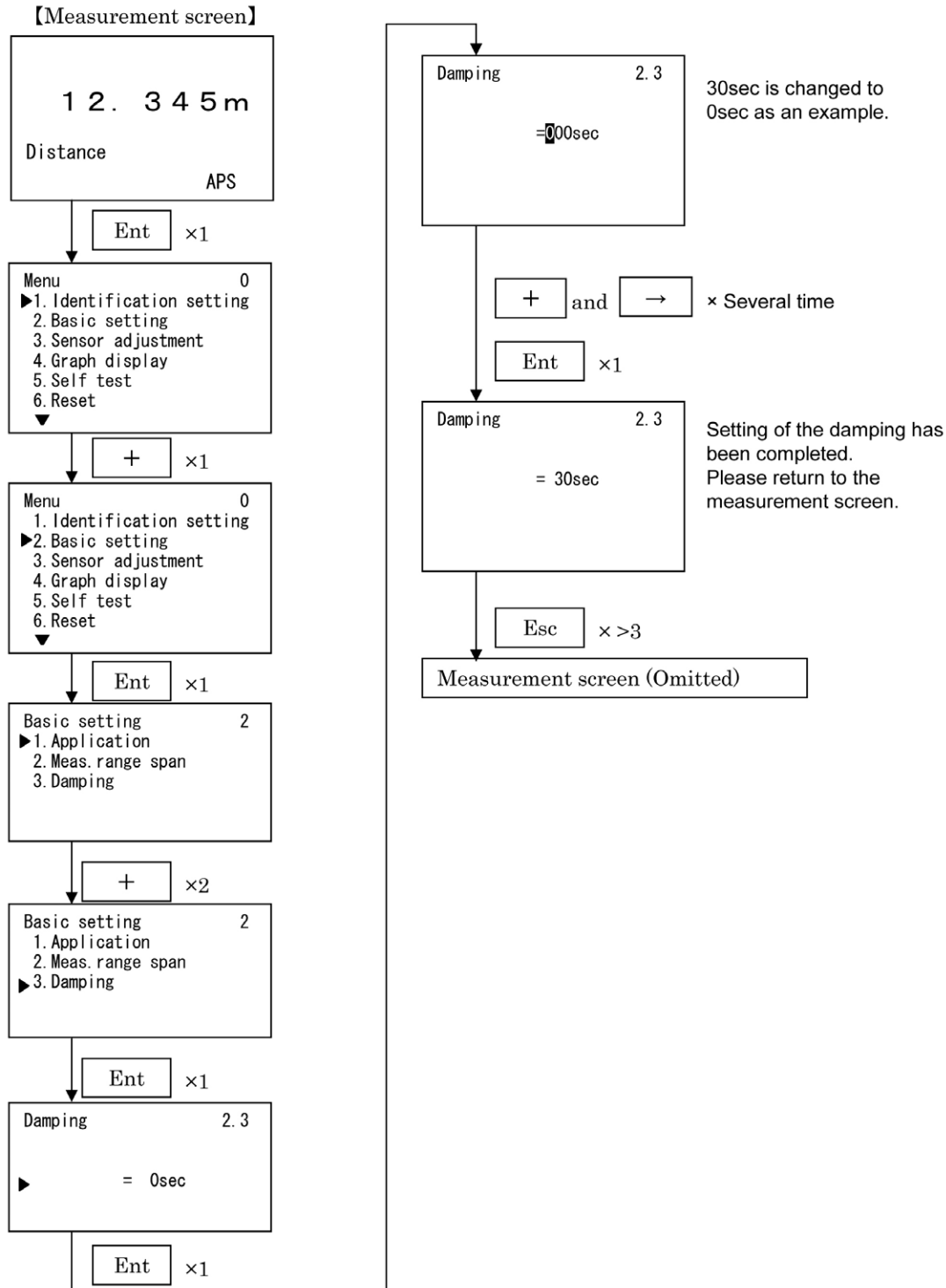

CURRENT OUTPUT

Selects the 4-20 mA current output mode corresponding to the process level 0-100% and alarm current value.

【Measurement screen】

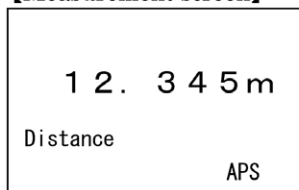

Ent ×1

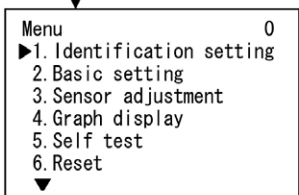

+ ×2

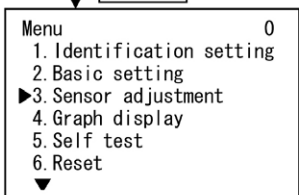

Ent ×1

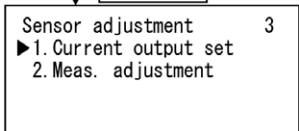

Ent ×1

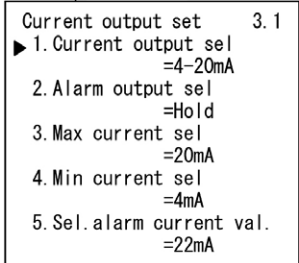

Ent ×1

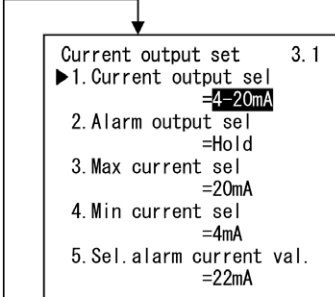

'20-4mA' is changed to '4-20mA' as an example.

+ ×1

Ent ×1

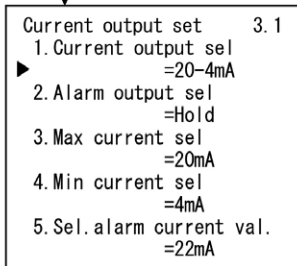

Setting of the current output set has been completed. Please return to the measurement screen.

Esc ×>3

Measurement screen (Omitted)

【Current output set other settings】

- "2.Alarm output sel". Selects alarm current value to output whenever measured value is not correct due to loss echo or other erroneous condition.
Possible selection: Hold / Sel.val / Max. / Min.
Hold → Output remains at previous measured result.
Sel.val → Value set by "5.Sel.alarm current val" is output.
Max. → Value set by "3.Max.current sel" is output.
Min. → Value set by "4.Min.current sel" is output.
- "3.Max.current sel". Selects current value to output when "Max." is selected by "2.Alarm output sel".
Possible selection: 20mA / 20.5mA / 22mA
- "4.Min.current sel ". Selects current value to output when "Min." is selected by "2.Alarm output sel".
Possible selection: 4mA / 3.6mA / 3.8mA
- "5.Sel.alarm current val". Sets current value to output when "Sel.val" is selected by "2.Alarm output sel".
Setting range: 3.6mA to 22.0mA

Meaning of "Current output sel" item
 『4-20mA』 = 100%Level(Upper level) : 20mA
 0%Level(Lower level) : 4mA
 『20-4mA』 = 100%Level(Upper level) : 4mA
 0%Level(Lower level) : 20mA

FALSE ECHO LEARNING

Sets mask to unwanted reflections (false echoes or noise echoes) being received from obstructions within a tank. When the material level is low, measure the exact distance inside the vessel to the material. Set the echo learning distance, 3 ft (1 m) less than the measured distance.

Tank should be empty when setting up the echo learning.

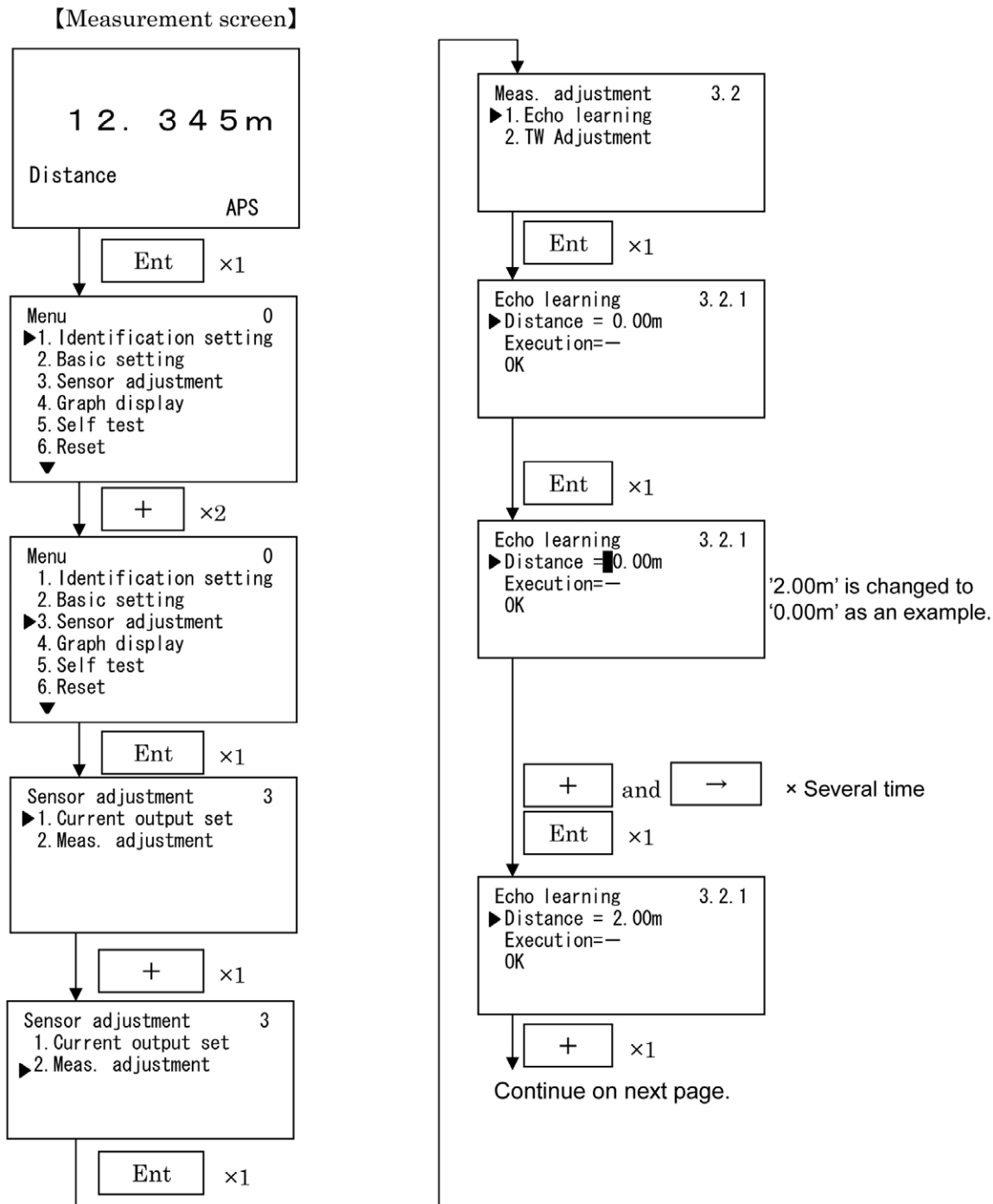

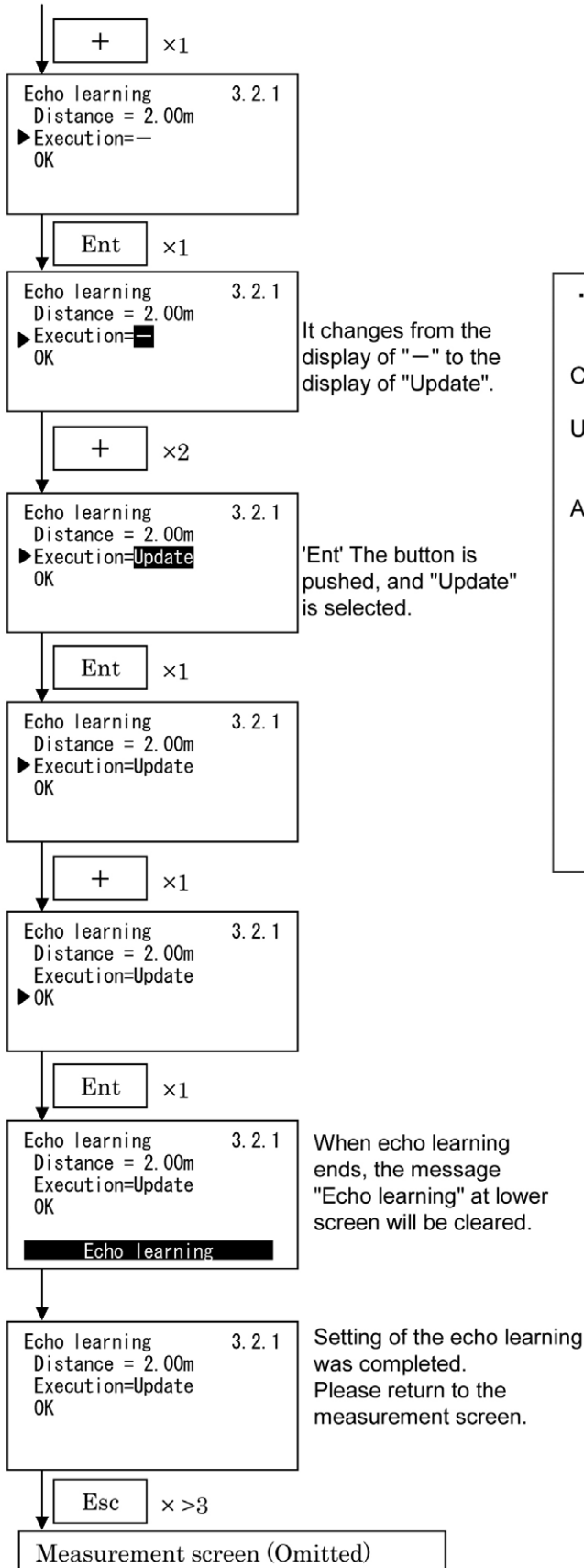

• "Selectable execution
【Clear/Update/Addition】

Clear : Deletes all echo learning data.

Update : Deletes current echo learning data and writes new data.

Addition : Addition of echo learning data
The data that had been input in the past is not deleted and new data is added.

RESET

There are two reset options. Use “Measuring reset” to restart measurement without affecting parameters. Use “Parameter reset” to reset parameters to the default settings.

NOTE: Parameter Reset

- Parameter reset returns various parameters to instrument default. Please take note of current settings before execute parameter reset.
- It is possible to clear echo learning range and strength by using the PC software, please call factory for assistance.
- There are two reset types described above, but there is menu item “Factory reset” might be displayed. This reset type used at factory setting and user can not apply this reset.

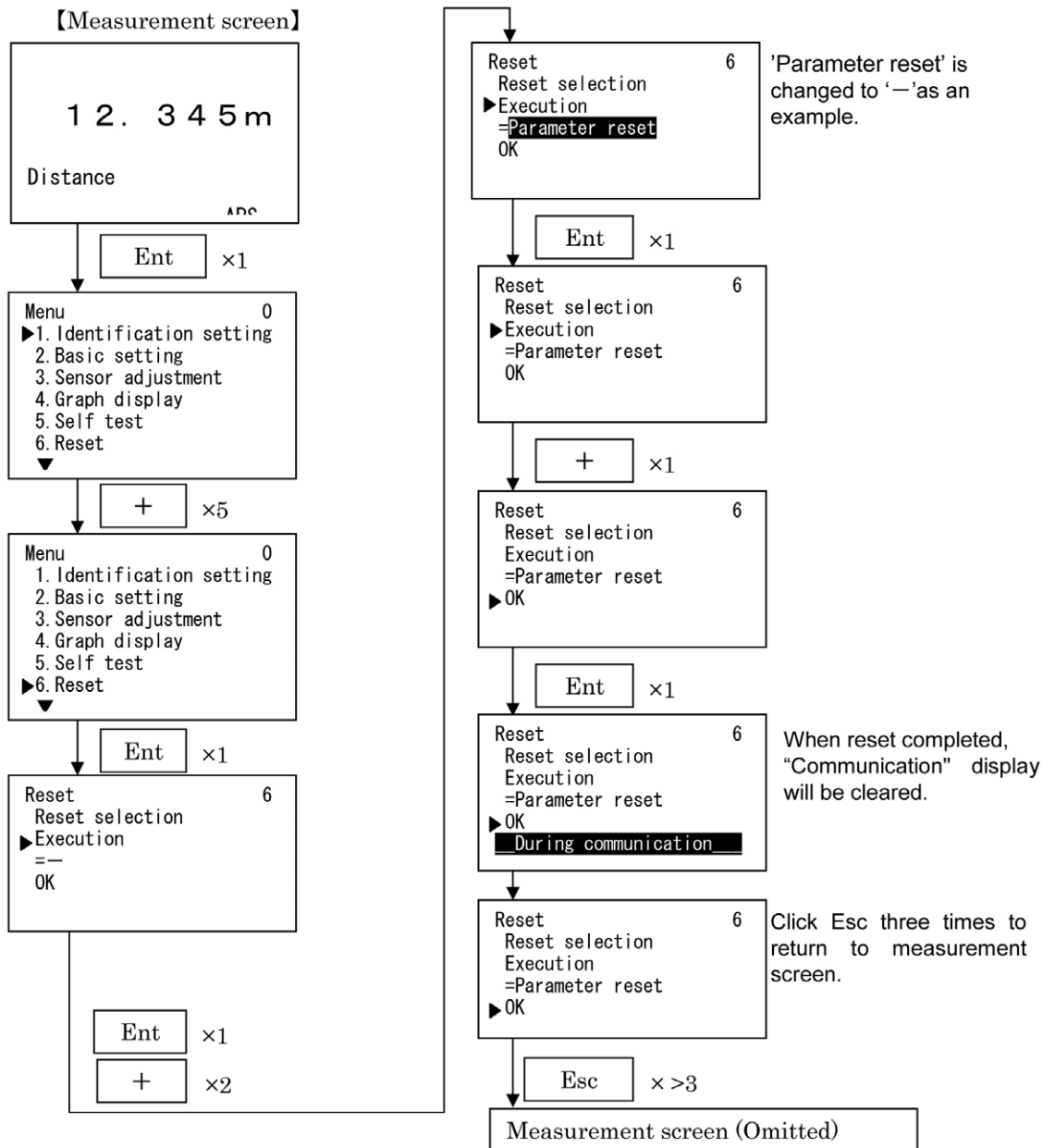

CURRENT OUTPUT TEST

Allows you to select a simulation value in order to test the functioning of the current output.

NOTE: When you are ready to end the simulation, click on 'Esc' to return the instrument to the actual level measurement.

【Measurement screen】

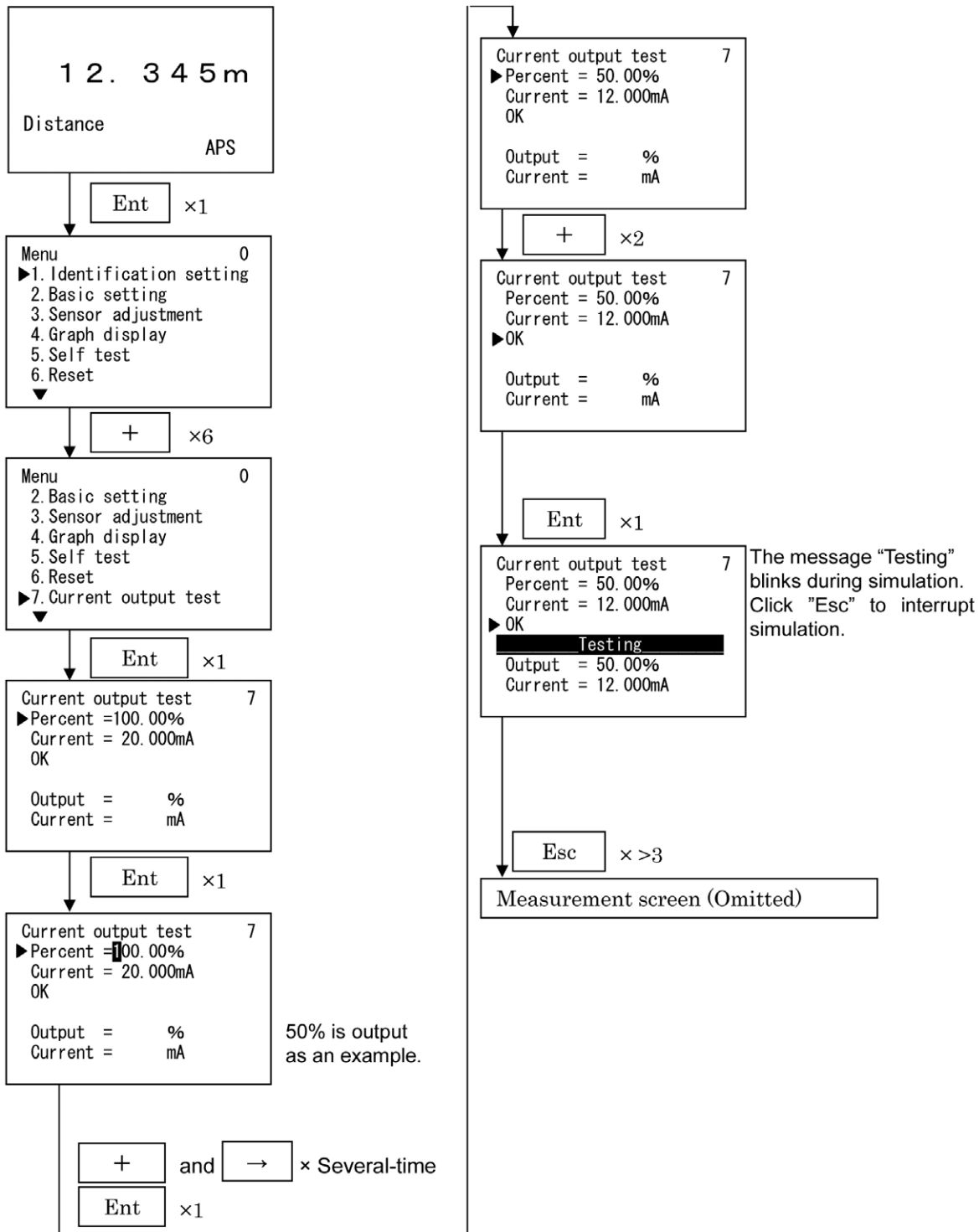

FULL MENU STRUCTURE

All values shown are defaults

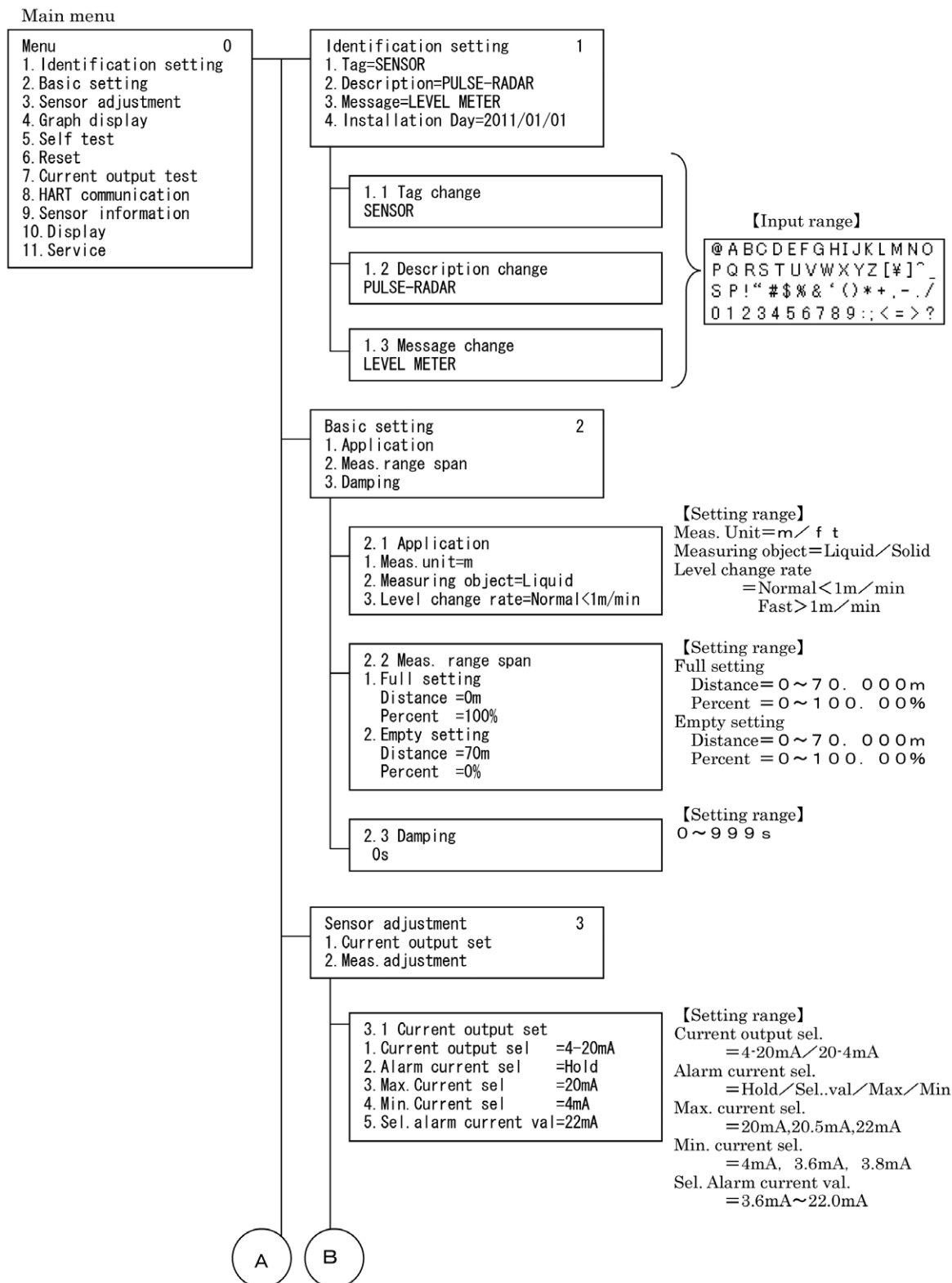

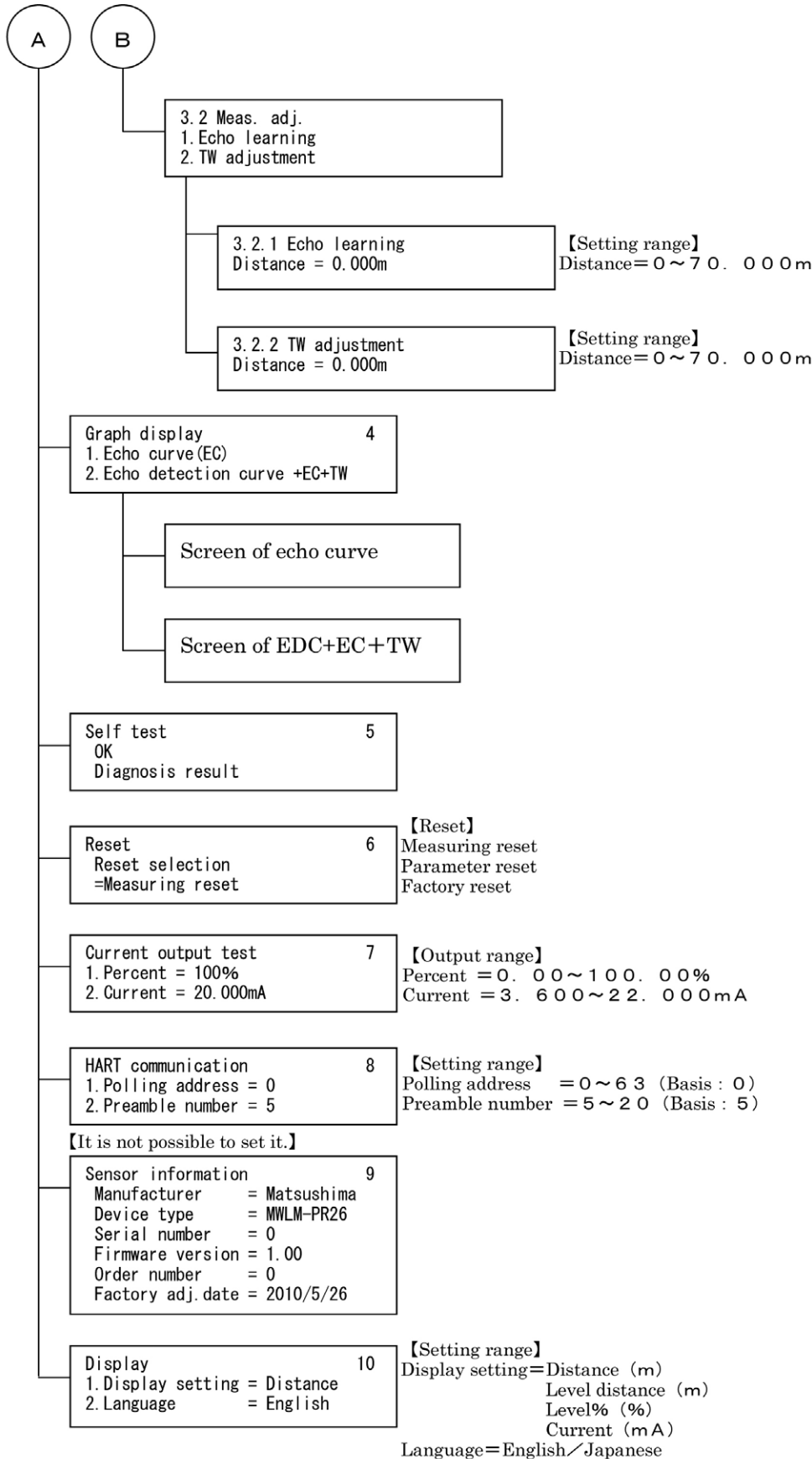

VII. MAINTENANCE

EVERY 6 MONTHS:

- Clean the antenna with a damp cloth; a mild cleaner can be used.

NOTE: In extremely dusty environments, more frequent cleanings may be required. Low pressure air can also be used to keep the antenna clean. Use the pipe plug used for purged air.

EVERY 12 MONTHS:

- Check to see if there is damage to the housing.
- Tighten the cover and cable gland.
- Tighten the bolt for installation fixture.

VIII. TROUBLESHOOTING

SYMPTOM	POSSIBLE CAUSE	CORRECTIVE ACTION
E8000	SRAM Error	Cycle power, if error does not clear contact factory
E4000	EEPROM Error	
E2000	MIC Error	
E1000	Trig Error	
E0800	LCD Error	Move (removable) LCD display to warmer/colder temperature. Cycle power, if error does not clear, contact factory
E0400	Charge error	Charge circuit error
E0200/S.12C	I2C Checksum error	Communication between level meter and LCD adjustment unit failed
E0080	Lost echo	There is no echo reflection, dielectric may be too low (minimum = 2) Unit may be installed too close the fill stream - move unit (see installation guidelines)
		There is no reflection echo in the measurement span, check dead zone; dielectric constant may be too low (minimum =2), Aiming of unit may need to be adjusted
E0008	Min. meas. Limit over	Check dead zone, obstructions and material level - adjust accordingly
E0004	Max. meas. Limit over	
E0002	Upper range limit over (100% over)	
E0001	Lower range limit over (0% over)	
S. CPU	Level meter not responding	Checking temperature of the unit, wiring and pressure of vessel, see appropriate sections of manual for guidelines
Powered ON the device, but screen is blank	Are wiring connections correct? Is power being supplied to the device?	Correct the wiring. Supply power to the device
Measured level reading higher than material level	Are there any obstructions between antenna and material surface to be measured?	Execute echo learning to mask false echo from the obstacle.
	Are there any inlet streams of material under measurement within the radiation angle	Change the level meter position
Measured level reading lower than material level	Check whether the material surface entered to the blind sector	Change level meter installation



150 Venture Boulevard
Spartanburg, SC 29306
Tel: (800) 778-9242
Fax: (864) 574-8063
sales@bindicator.com
www.bindicator.com

venture
MEASUREMENT

2014 All rights reserved.
All data subject to change without notice.

MPR180213 Rev. B