



Roto-Bin-Dicator®
Super-Safe & Super-Safe Plus
Installation & Operation Manual



Roto-Bin-Dicator[®] Super-Safe and Super-Safe Plus Installation & Operation Manual

CONTENTS

I.	HANDLING & STORAGE.....	1
	Inspection and Handling	
	Disposal and Recycling	
	Storage	
II.	GENERAL SAFETY.....	2
	Authorized Personnel	
	Use	
	Misuse	
III.	PRODUCT DESCRIPTION.....	3
	Technical Specifications	
	Approvals	
IV.	MECHANICAL INSTALLATION	4
	Mounting Location	
	Mounting Surface Preparation	
	Mounting on Side of Bin	
	Mounting on Top of Bin	
V.	ELECTRICAL INSTALLATION.....	6
	Super-Safe (24 VDC)	
	Figure 1. Super-Safe (24 VDC) Fail-Safe Operation	
	Super-Safe Plus (120/240 VAC)	
	Figure 2. Board Layout	
	Figure 3. Super-Safe Plus (120/240 VAC) Fail-Safe Operation	
VI.	MAINTENANCE	12
	Preventative Maintenance	

SAFETY SYMBOLS



WARNING:

IDENTIFIES CONDITIONS OR PROCEDURES, WHICH IF NOT FOLLOWED, COULD RESULT IN SERIOUS INJURY. RISK OF ELECTRICAL SHOCK.



CAUTION:

IDENTIFIES CONDITIONS OR PROCEDURES, WHICH IF NOT FOLLOWED, COULD RESULT IN SERIOUS DAMAGE OR FAILURE OF THE EQUIPMENT.

Roto-Bin-Dicator® Super-Safe and Super-Safe Plus

I. HANDLING AND STORAGE

SAVE THESE INSTRUCTIONS

INSPECTION AND HANDLING

Do not dispose of the carton or packing materials.

Each package should be inspected upon receipt for damage that may have occurred due to mishandling during shipping. If the unit is received damaged, notify the carrier or the factory for instructions. Failure to do so may void your warranty. If you have any problems or questions, consult Customer Support at 1-800-778-9242.

DISPOSAL AND RECYCLING

This product can be recycled by specialized companies and must not be disposed of in a municipal collection site. If you do not have the means to dispose of properly, please contact Bindicator for return and disposal instructions or options.

STORAGE

If the device is not scheduled for immediate installation following delivery, the following steps should be observed:

1. Following inspection, repackage the unit into its original packaging.
2. Select a clean dry site, free of vibration, shock and impact hazards.
3. If storage will be extended longer than 30 days, the unit must be stored at temperatures between 32° and 158° F (0° to 70° C) in non-condensing atmosphere with humidity less than 85%.



CAUTION: DO NOT STORE A NON-POWERED UNIT OUTDOORS FOR A PROLONGED PERIOD.

II. GENERAL SAFETY



WARNING: ONLY CERTAIN MODELS CAN BE USED IN HAZARDOUS LOCATIONS; SEE NAMEPLATE. THESE MODELS SHALL ONLY BE USED IN APPLICATIONS COVERED BY THE STATED RATINGS OR NON-HAZARDOUS LOCATIONS.

AUTHORIZED PERSONNEL

All instructions described in the document must be performed by authorized and qualified service personnel only. Before installing the unit, please read these instructions and familiarize yourself with the requirements and functions of the device. The required personal protective equipment must always be worn when servicing this device.

USE

The device is solely intended for use as described in this manual. Reliable operation is ensured only if the instrument is used according to the specifications described in this document. For safety and warranty reasons, use of accessory equipment not recommended by the manufacturer or modification of this device is explicitly forbidden. All servicing of this equipment must be performed by qualified service personnel only. This device should be mounted in locations where it will not be subject to tampering by unauthorized personnel.

MISUSE

Improper use or installation of this device may cause the following:

- Personal injury or harm
- Application specific hazards such as vessel overfill
- Damage to the device or system

If any questions or problems arise during installation of this equipment, please contact the Customer Support at 800-778-9242.

III. PRODUCT DESCRIPTION

SUPER-SAFE

The RPM synchronous motor either turns the paddle in the absence of bulk-material or actuates DPDT 5A relay contacts when the paddle is stopped by the bulk material. An optical transmitter/receiver, in combination with a pulse wheel, monitors the rotation of the shaft to ensure the clutch assembly is fully operational.

SUPER-SAFE PLUS

The RPM synchronous motor either turns the paddle in the absence of bulk-material or actuates relay contacts when the paddle is stopped by the bulk material. An optical transmitter/receiver, in combination with a pulse wheel, monitor the rotation of the shaft to ensure the clutch assembly and motor is fully operational. An optical motor position sensor detects the presence or absence of material on the paddle.

TECHNICAL SPECIFICATIONS

FUNCTIONAL	
Operating Power	Super-Safe: 24 VDC; Super-Safe Plus: 120/240 VAC; 50/60 Hz
Power Consumption	7 watts
Motor	SuperSafe = 2 rpm; SuperSafe Plus = 1 rpm
Fuse	1/8 amp internally fused
Relay	Level Alarm: Super-Safe: DPDT, 5A @ 277 VAC, 5A @ 30 VDC; Super-Safe Plus: SPDT 10A @ 125 VAC, 6A @ 277 VAC, 5A @ 30 VDC Failure Indication: Super-Safe: NA; Super-Safe Plus: 0.6 amps at 125 VAC
Fail-Safe Circuitry	Low or high level field selectable
Operating Temperature	-40° to 113° F (-40° to 45° C)
Time Delay	Super-Safe: 10 seconds; Super-Safe Plus: 3 seconds
Pollution Degree	2
Installation Category	II
Altitude	6,462 ft (2,000 m)
PHYSICAL	
Drive Shaft Assembly	Precision machined shaft with two shielded ball bearings
Shaft Seal	Teflon®/Viton® Lipseal rated 1/2 Micron at 30 psi (2.1 kg/cm ²) at 400° F (204° C)
Housing and Cover	Type 4X/IP66; Polyester-coated aluminum casting
Mounting Plate	8" outside diameter with 1 1/4" NPT pipe threaded coupling; standard polyester coated mild steel; optional 304 SS
Conduit Entry	3/4" NPT or M20 x 1.5
Rigid Shaft and Paddle	Metal parts of all designs are 304 Stainless Steel
Flex Shaft	Available in either neoprene, 155° F (68° C) or silicone, 400° F (204° C) coatings
Pulse Wheel	Multi-toothed pulse wheel with an opti-reflective circuit
External Lights	Green (power/diagnostics) and red (alarm/diagnostics) lights
Shipping Weight	Aluminum housing 10 lbs (4.5 kg), Stainless Steel Housing 16 lbs (7.3 kg)

APPROVALS & RATINGS

UL (US and Canada):

- Ordinary Location Type 4X; IP66
- Hazardous Location, Type 4X
- Explosion Proof
- Dust Ignition Proof

CE:

- Electromagnetic Compatibility Directive
- Low Voltage Directive

IV. MECHANICAL INSTALLATION



WARNING: REMOVE POWER FROM THE UNIT BEFORE INSTALLING, REMOVING, OR MAKING ADJUSTMENTS.



WARNING: IN ORDER TO MAINTAIN SAFE OPERATION IN HAZARDOUS LOCATIONS, THE INTEGRITY OF THE ALUMINUM CASTING AND THE EPDM SEALS MUST BE MAINTAINED. THE USER/INSTALLER MUST AVOID INSTALLATIONS WHERE AGGRESSIVE SUBSTANCES MAY BE PRESENT AND COULD AFFECT THE PERFORMANCE OF THESE MATERIALS. CARE MUST BE EXERCISED WHEN REMOVING AND REPLACING THE COVER, SO NO MARRING, SCRATCHING OR DAMAGE OCCURS TO THE FLANGES.



WARNING: FOR UNITS INSTALLED IN HAZAROUS LOCATIONS, TO REDUCE THE RISK OF IGNITION OF HAZARDOUS ATMOSPHERES, CONDUIT RUNS MUST HAVE A SEALING FITTING CONNECTING WITHIN 18 IN. OF THE ENCLOSURE.



WARNING: FOR PRODUCTS MARKED AS TYPE 4X, USE TYPE 4X HUB FITTING; FOR IP66 USE IP66 HUB FITTING.



CAUTION: WHEN MOUNTING UNITS, NEVER ADJUST THE ORIENTATION BY TURNING THE HOUSING. USE 2-1/4 IN. WRENCH FOR PROCESS FITTING UNITS, OTHERWISE A STRAP WRENCH SHOULD BE USED TO TIGHTEN INTO PLACE.

GUIDELINES

The following precautions should be observed when installing and operating a Roto-Bin-Dicator PRO device:

- The installation and wiring of this product must comply with all national, federal, state, municipal and local codes that apply.
- Handle carefully to prevent damage.
- Do not allow moisture to enter the electronics enclosure. Conduit should slope downward from the housing. Install drip loops (or drain fitting) and seal conduit with silicone rubber product.
- For horizontally mounted units, the conduit openings must face downward.

The unit must be located at the position where level indication is desired. The unit may be mounted through the top or side wall of the vessel. To ensure reliable operation, observe the following guidelines when choosing the mounting location.

- DO NOT mount the Roto-Bin-Dicator PRO in an area where the paddle or shaft can contact the vessel.
- DO NOT mount the Roto-Bin-Dicator PRO where the paddle or shaft are directly in the flow of material. The material should be able to flow on to and away from the paddle. If necessary, use a baffle to protect the paddle and shaft from falling material (ie. avalanche, mass flow and in-coming flow stream). The baffle should be placed 6 to 12 inches above the paddle, distance depend on paddle size.

INSTALLATION FOR USE WITH MOUNTING PLATES

1. On a 7 in. bolt circle, drill and tap or drill 6 equally spaced holes in the bin wall for 1/4 in. bolts or cap screws. If not tapped, bolt heads should be tack welded to the bin inner wall.
2. Cut a 5 in. diameter hole to pass the paddle through. Contact factory for non-standard wall thickness greater than 1/4 in.

MOUNTING - SIDE OF BIN

1. Conduit opening must face down.
2. Assemble gasket between the mounting plate and the bin wall.
3. Flat washer, customer supplied, is recommended between mounting plate and fastening hardware.

Mounting Plate & Gasket Diagram

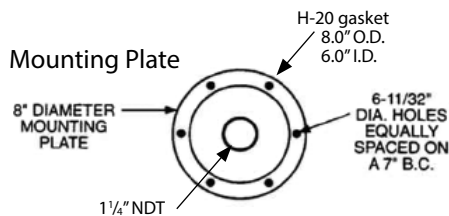

MOUNTING - TOP OF BIN

1. Assemble gasket between the mounting plate and the bin.
2. Flat washer, customer supplied, is recommended between mounting plate and fastening hardware.

NOTE: All extended units should have shaft guard and/or flex coupling.

NOTE: Extended units with shaft lengths greater than 12 inches require a shaft guard.

NOTE: It is recommended that the shaft guard be braced to bin wall at 6 foot intervals.

INSTALLATION FOR USE WITHOUT MOUNTING PLATES

Preferred mount is through half couplings; a full coupling will allow material to collect around the shaft, which may cause additional drag on the rotating shaft.

V. ELECTRICAL INSTALLATION



WARNING: REMOVE POWER FROM THE UNIT BEFORE INSTALLING, REMOVING, OR MAKING ADJUSTMENTS.



WARNING: FOR UNITS INSTALLED IN HAZAROUS LOCATIONS, TO REDUCE THE RISK OF IGNITION OF HAZARDOUS ATMOSPHERES, CONDUIT RUNS MUST HAVE A SEALING FITTING CONNECTING WITHIN 18 IN. OF THE ENCLOSURE.



WARNING: FOR PRODUCTS MARKED AS TYPE 4X, USE TYPE 4X HUB FITTING; FOR IP66 USE IP66 HUB FITTING.



CAUTION: IF THE UNIT WAS SUPPLIED WITH A GASKET, AVOID FOLDING, CUTTING OR TEARING THE GASKET. DAMAGING THE GASKET CAN ALLOW MOISTURE TO ENTER THE ENCLOSURE AND DAMAGER THE UNIT



CAUTION: TO REDUCE THE RISK OF IGNITION IN HAZARDOUS ATMOSPHERES, DISCONNECT THE EQUIPMENT FROM SUPPLY CURCIUT BEFORE OPENING. KEEP ASSEMBLY TIGHTLY CLOSE WHEN IN OPERATION.

GENERAL SAFETY

When using electrical equipment, you should always follow basic safety precautions, including the following:

- Units installed in hazardous locations must observe all government regulations regarding equipment in hazardous locations.
- The installation and wiring of this product must comply with all national, federal, state, municipal, and local codes that apply.
- Properly ground the enclosure to an adequate earth ground.
- Do not modify any factory wiring. Connections should only be made to the terminals described in this section.
- All connections to the unit must use conductors with an insulation rating of 300 V minimum, rated for 212° F (105° C), a minimum flammability rating of VW-1, and be of appropriate gauge for the voltage and current required (see specifications).
- Do not allow moisture to enter the electronics enclosure. Conduit should slope downward from the unit housing. Install drip loops and seal conduit with silicone rubber product.

DISCONNECT REQUIREMENTS FOR PERMANENTLY INSTALLED EQUIPMENT



A dedicated disconnecting device (circuit breaker) must be provided for the proper installation of the unit. If independent circuits are used for power input and main relay outputs, individual disconnects are required.

Disconnects must meet the following requirements:

- Located in close proximity to the device
- Easily accessible to the operator

- Appropriately marked as the disconnect for the device and associated circuit
- Sized appropriately to the requirements of the protected circuit (See specifications)

PROTECTIVE EARTH GROUND

To eliminate shock hazards in the unlikely event of an internal insulation breakdown, the unit is provided with a “protective earth” () lead which must be connected to earth ground. In addition, the input power ground lead must be connected to the “protective earth” () terminal provided. Wire sizes must be selected such that it can safely carry the sum total of all circuits’ maximum amperage.

WIRING

1. Connect the power source for the motor to the terminal block. Continuous power is essential. The motor may be stalled indefinitely without damage.
2. Make wiring connections to the control micro switch using a separate circuit from that of the motor.
3. Apply power to the motor circuit, checking the freeness of operation and actuation of the micro switch.
4. Fasten the housing cover securely to prevent damage from dust or moisture.

SUPER-SAFE (24 VDC)

TIME DELAY FOR RELAY OUTPUT

1. The time delay can be customized in four different ways. This involves clipping either one or both delay diodes and adjusting the time delay potentiometer. The time delay potentiometer is adjustable for 0 to 30 seconds.
2. For delay after material falls below the paddle and the paddle starts turning, clip D9 and adjust the time delay potentiometer CLOCKWISE.
3. For delay after the material covers the paddle and the paddle stops turning, clip D10 and adjust the time delay potentiometer CLOCKWISE.
5. For zero time delay (no delay), do NOT clip D9 or D10; adjust the time delay potentiometer as necessary.

EXTERNAL LIGHTS

The green external LED signals that the unit has input power, and the red external LED signals that the unit is in alarm.

FAIL-SAFE SELECTION

This feature allows the operator to select the desired alarm state should input power ever fail. Refer to Figure 1 for relay alarm/non-alarm states.

To select High Level Fail-Safe, move the fail-safe selector switch to HLFS position.

To select Low Level Fail-Safe, move the fail-safe sector switch to LLFS position.

FUNCTION TEST FEATURE

1. With material below paddle, place the FOB so that holes are aligned over the two external LEDs on the cover.
2. If the fail-safe switch is positioned in HLFS, the red LED will illuminate and the relay will change output state.
3. If the fail-safe switch is positioned in LLFS, the red LED will illuminate and the relay will change output state.

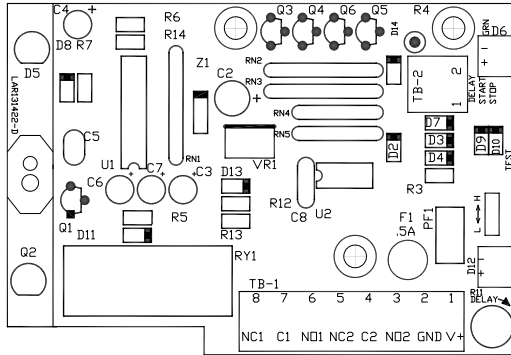

Figure 1. Super-Safe (24 VDC) Fail-Safe Operation

	HIGH LEVEL FAIL-SAFE		LOW LEVEL FAIL-SAFE	
	Level BELOW Paddle		Level ABOVE Paddle	
NORMAL MODE				
Non-Alarm State Relay Energized		<ul style="list-style-type: none"> ○ NC2 ○ C2 ○ NO2 ○ NC1 ○ C1 ○ NO1 		<ul style="list-style-type: none"> ○ NC2 ○ C2 ○ NO2 ○ NC1 ○ C1 ○ NO1
	Level AT Paddle		Level BELOW Paddle	
Alarm State Relay Not Energized		<ul style="list-style-type: none"> ○ NC2 ○ C2 ○ NO2 ○ NC1 ○ C1 ○ NO1 		<ul style="list-style-type: none"> ○ NC2 ○ C2 ○ NO2 ○ NC1 ○ C1 ○ NO1
	HIGH LEVEL FAIL-SAFE		LOW LEVEL FAIL-SAFE	
FAIL MODE	Level BELOW Paddle		Level ABOVE Paddle	
		<ul style="list-style-type: none"> ○ NC2 ○ C2 ○ NO2 ○ NC1 ○ C1 ○ NO1 		<ul style="list-style-type: none"> ○ NC2 ○ C2 ○ NO2 ○ NC1 ○ C1 ○ NO1
	Level AT Paddle		Level BELOW Paddle	
Alarm State Relay Not Energized		<ul style="list-style-type: none"> ○ NC2 ○ C2 ○ NO2 ○ NC1 ○ C1 ○ NO1 		<ul style="list-style-type: none"> ○ NC2 ○ C2 ○ NO2 ○ NC1 ○ C1 ○ NO1

RELAY OUTPUTS

The relay contacts are dry, unpowered contacts. The desired voltage must be brought into the relay common in order to provide an output. The output contacts are rated 5A maximum.

SUPER-SAFE PLUS (120/240 VAC)

TIME DELAY FOR RELAY OUTPUT

The time delay can be customized in four different ways. This involves setting DIP switch SW3 and adjusting the time delay potentiometer. See Figure 2 for location. The time delay potentiometer is adjustable for 3 to 30 seconds.

1. For delay after material falls below the paddle and the paddle starts turning, set DIP switch SW3 with Switch 1 ON and 2 OFF and adjust the time delay potentiometer CLOCKWISE.
2. For delay after material covers the paddle and the paddle stops turning, set DIP switch SW3 with Switch 1 OFF and 2 ON and adjust the time delay potentiometer CLOCKWISE.
3. For zero time delay (no delay), set DIP switch SW3 with Switch 1 and 2 OFF; adjust the time delay potentiometer completely COUNTERCLOCKWISE.
4. For delay when the paddle starts and stops, set DIP switch SW3 with Switch 1 and 2 ON. Adjust the time delay potentiometer as necessary.

EXTERNAL LIGHTS

The external red and green LEDs are used to indicate alarm and failure modes. See chart below for explanation of each condition.

Red LED	Green LED	Indication
OFF	OFF	No power to unit
OFF	ON	Normal, non-alarm condition
ON	ON	Material level alarm (Note 1)
ON	FLASHING	Cavitation of paddle (Note 2)
OFF	FLASHING	Cavitation of paddle (Note 3)
FLASHING	OFF	Failure (Note 4)
FLASHING	FLASHING	Test mode (Note 5)

Note 1: If unit is set in "High level Fail-Safe" (HLFS) this condition means material is present on the paddle; if unit is set in "Low level Fail-Safe" (LLFS) this condition means no material is at the paddle.

Note 2: Paddle rotation is not completely stalled with material on the paddle, but has detected the material presence. Output relays do indicate material presence. This may be normal in light of fluffy materials.

Note 3: Same as Note 2, however unit is in LLFS.

Note 4: Unit has failed to sense paddle rotation and motor has not moved to the material presence position.

Note 5: Indication when external test FOB is used; see "Function Test Feature".

FAIL-SAFE SELECTION

This feature allows the operator to select the desired alarm state should input power ever fail. Refer to Figure 3 for relay alarm/non-alarm states.

To select High Level Fail-Safe, move the fail-safe selector switch to HL position.

To select Low Level Fail-Safe, move the fail-safe sector switch to LL position.

FUNCTION TEST FEATURE

With material below the paddle, place the FOB so that the holes are aligned over the two external LEDs on the cover.

- The red and green LED will blink on and off in tandem, and the "Level Alarm" relay will indicate material presence. If Jumper JU2 is cut, the "Failure Indication" relay will indicate failure condition

Figure 2. Board Layout

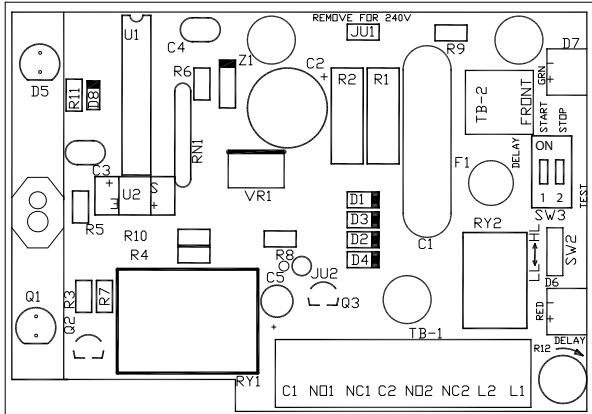
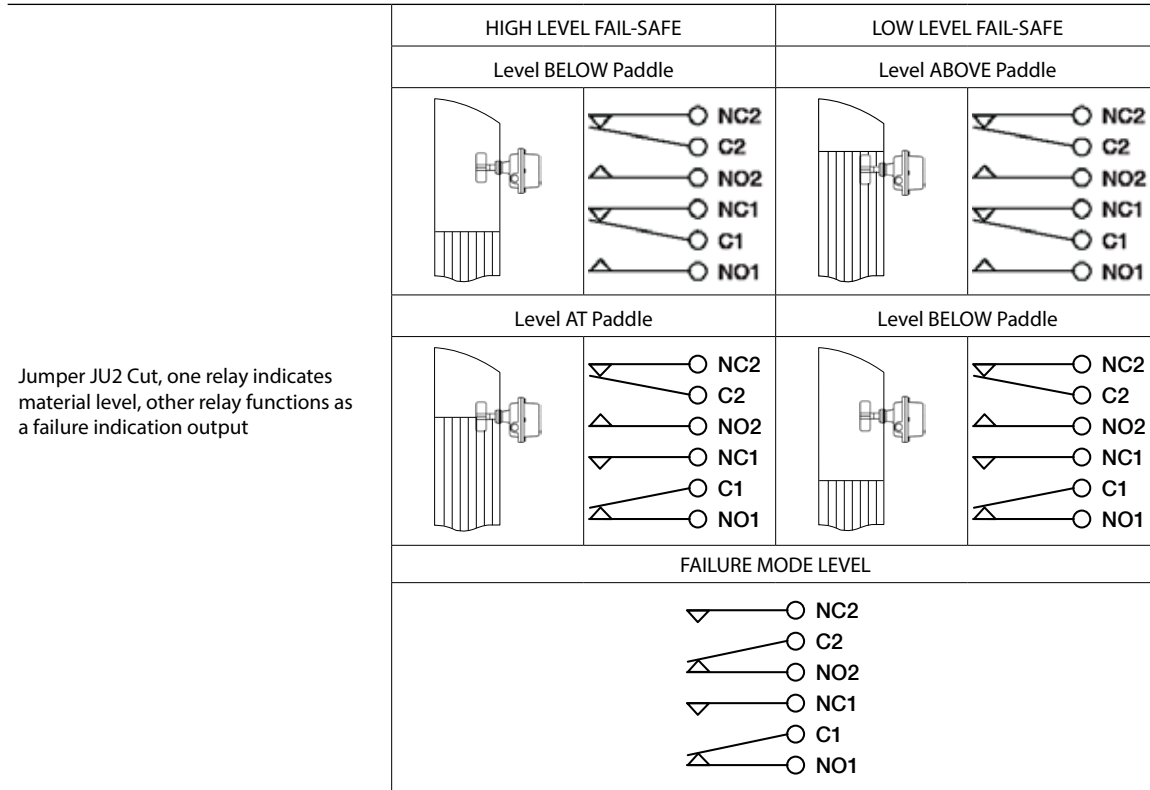

Figure 3. Super-Safe Plus (120/240 VAC) Fail-Safe Operation

		HIGH LEVEL FAIL-SAFE	LOW LEVEL FAIL-SAFE
		Level BELOW Paddle	Level ABOVE Paddle
Jumper JU2 Intact, both relays indicating material level		<ul style="list-style-type: none"> ○ NC2 ○ C2 ○ NO2 ○ NC1 ○ C1 ○ NO1 	<ul style="list-style-type: none"> ○ NC2 ○ C2 ○ NO2 ○ NC1 ○ C1 ○ NO1
	Level AT Paddle		Level BELOW Paddle
		<ul style="list-style-type: none"> ○ NC2 ○ C2 ○ NO2 ○ NC1 ○ C1 ○ NO1 	<ul style="list-style-type: none"> ○ NC2 ○ C2 ○ NO2 ○ NC1 ○ C1 ○ NO1
	FAILURE MODE LEVEL IN ANY POSITION		
		<ul style="list-style-type: none"> ○ NC2 ○ C2 ○ NO2 ○ NC1 ○ C1 ○ NO1 	



RELAY OUTPUTS

There are two separate SPDT relays on the Super-Safe Plus. The main “level alarm” relay has contacts rated 10A. The contacts are connected to the output terminal block positions 6, 7 and 8. The second relay has contacts rated 0.6A. These contacts are connected to the output terminal block positions 3, 4 and 5.

The secondary relay can be used in two ways:

1. As an additional level alarm relay, mimicking the level alarm. This will then allow a DPDT “level alarm” output giving two separate isolated contacts for level indication if needed. This is the factor default position setting.
2. As a separate “Failure Indication” relay, when jumper JU2 is cut, the relay will change state only when a ‘failure’ status is sensed. A failure condition consists of :
 - a. No input power
 - b. Motor or clutch failure
 - c. Circuit board failure

To enable the second relay as a “failure” indication relay, cut jumper JU2 (See Figure 3)



WARNING: TURN OFF POWER BEFORE CUTTING JUMPER.

NOTE: The main level alarm relay changes state with changes in material level. It will also change state to the alarm position when a failure is sensed. See Figure 3 for contact positions at various states.

VI. MAINTENANCE



WARNING: IN ORDER TO MAINTAIN SAFE OPERATION IN HAZARDOUS LOCATIONS, THE INTEGRITY OF THE ALUMINUM CASTING AND THE EPDM SEALS MUST BE MAINTAINED. THE USER/INSTALLER MUST AVOID INSTALLATIONS WHERE AGGRESSIVE SUBSTANCES MAY BE PRESENT AND COULD AFFECT THE PERFORMANCE OF THESE MATERIALS. CARE MUST BE EXERCISED WHEN REMOVING AND REPLACING THE COVER, SO NO MARRING, SCRATCHING OR DAMAGE OCCURS TO THE FLANGES.



CAUTION: IF THE UNIT WAS SUPPLIED WITH A GASKET, AVOID FOLDING, CUTTING OR TEARING THE GASKET. DAMAGING THE GASKET CAN ALLOW MOISTURE TO ENTER THE ENCLOSURE AND DAMAGER THE UNIT

PREVENTATIVE MAINTENANCE

No scheduled preventative maintenance is required for the Roto-Bin-Dicator® units when properly applied and installed correctly. There is no cleaning required for the unit before or during installation.

If the cover is removed after the unit has been in service, it is recommended to replace the gasket to prevent the ingress of water or dust. At a minimum, the gasket (or o-ring, used in hazardous locations) should be inspected for folds, cracks and tears.

RECOMMENDED SPARE PARTS

MOUNTING PLATES

Includes H-20 Mounting Gasket

PART NUMBER	MODEL	DESCRIPTION
LAR110130	H-19	Mild Steel (Side of Bin)
LAR110140	H-19SS	304 Stainless Steel (Side of Bin)
LAR110180	H-192	Mild Steel (Top of Bin)
LAR110190	H-192SS	304 Stainless Steel (Top of Bin)

SHAFT COUPLINGS

PART NUMBER	MODEL	DESCRIPTION
LAR110270	H-36	Neoprene 3 in. Flexible Shaft; 170° F (77° C) Max Temp
LAR120640	H-38	Stainless Steel, 3 in.
LAR110275	H-36S	Molded Silicone 3 in. Flexible Shaft; 400° F (204° C) Max Temp

PADDLES

All are stainless steel except model H-373.

PART NUMBER	MODEL	DESCRIPTION
LAR110310	H-370	4-Vane; 1 1/2" x 5" Diameter with Pins
LAR110360	H-371	4-Vane; 2" x 7" Diameter with Pins
LAR110430	H-373	Multiflex; Solid Neoprene 1 1/2" x 24" with Pins
LAR110450	H-374	Multiflex; Stainless Steel 1 1/2" x 17" with Pins
LAR111037	H-379	1-Vane; Insertable with Pins
LAR111040	H-372A	1-Vane; 1" x 2 7/8" with 45° Cut
LAR111200	H-380	2-Vane Collapsible, Stainless Steel

NOTE. Consult the manufacturing facility on applications where the housing ambient temperature is above 200° F (93° C).

SHAFT EXTENSIONS

PART NUMBER	DESCRIPTION
LUB040500	316 Stainless Steel, 1/8 in. pipe

SHAFT GUARDS

PART NUMBER	DESCRIPTION
LUB040510	316 Stainless Steel, 1-1/4" NPT

SUPER-SAFE AND SUPER-SAFE-PLUS ROTO-BIN-DICATOR® -LEGACY MODELS

PART NUMBER	DESCRIPTION
LAR111115	120 VAC Super-Safe-Plus Roto-Bin-Dicator PCB Assembly
LAR111116	240 VAC Super-Safe-Plus Roto-Bin-Dicator PCB Assembly
LAR111119	110 VAC Super-Safe-Plus Roto-Bin-Dicator Motor Assembly
LAR111120	220 VAC Super-Safe-Plus Roto-Bin-Dicator Motor Assembly
LAR131436	Function Test FOB (Super-Safe-Plus Roto-Bin-Dicator ONLY)
LUCK03920	120-240 VAC Super-Safe-Plus Roto-Bin-Dicator Fuse (LUC039203), Pack of 5
LUAK032282	Super-Safe-Plus Roto-Bin-Dicator Spring (LUA032282), Pack of 5
LAR110110	Motor Replacement Kit: 24 VDC Heavy Duty Super-Safe Roto-Bin-Dicator 1rpm, 50/60Hz
LAR111096	24 VDC Super-Safe Roto-Bin-Dicator PCB Assembly
LAR131420	Function Test FOB (Super-Safe Roto-Bin-Dicator ONLY)
LAR110015	Cover Assembly (General Purpose): Aluminum LP1

SUPER-SAFE AND SUPER-SAFE-PLUS ROTO-BIN-DICATOR® -NEW FRAME MODELS

PART NUMBER	DESCRIPTION
LAR111115	120 VAC Super-Safe-Plus Roto-Bin-Dicator PCB Assembly
LAR111116	240 VAC Super-Safe-Plus Roto-Bin-Dicator PCB Assembly
LAR111119	110 VAC Super-Safe-Plus Roto-Bin-Dicator Motor Assembly
LAR111120	220 VAC Super-Safe-Plus Roto-Bin-Dicator Motor Assembly
LAR131436	Function Test FOB (Super-Safe-Plus Roto-Bin-Dicator ONLY)
LUCK039203	120-240 VAC Super-Safe-Plus Roto-Bin-Dicator Fuse (LUC039203), Pack of 5
LUA032282	Super-Safe-Plus Roto-Bin-Dicator Spring
LAR110110	Motor Replacement Kit: 24 VDC Heavy Duty Super-Safe Roto-Bin-Dicator 1rpm, 50/60Hz
LAR111096	24 VDC Super-Safe Roto-Bin-Dicator PCB Assembly
LAR131420	Function Test FOB (Super-Safe Roto-Bin-Dicator ONLY)
LUBK43300	Fiber Gaskets, Pack of 5
LUBK43304	Fiber Gasket, Metric, Pack of 5
LUBK43314	G-Thread Fitting Gasket, Pack of 5
LUBK43003	Cover Hardware (with lights)
LUBK43004	Cover Hardware (with lights), Metric

MISCELLANEOUS ROTO-BIN-DICATOR® PARTS

PART NUMBER	DESCRIPTION
LUAK031190	Pin for Paddles (5954), Pack of 20 (LUA031190)
LAR121930	Stub Shaft with Pins (H-35)
LAR122142	316 Stainless Steel Tag
LAR131230	Lip Seal, RBD
LAR131413	Lip Seal, 90 psi
LARK30380	H-20 Gasket (LAR30380) used with H-19/H-192 Mounting Plate Gasket, Pack of 5

LOWER HOUSING ASSEMBLY

****NOT FOR EXPLOSION PROOF UNITS**:** Bindicator® does not recommend the customer replacing the H-21 Clutch Assembly. Instead, replace the lower housing assembly, which includes all of the parts listed below.

DETAIL NUMBER	PART NUMBER	DESCRIPTION	QTY REQUIRED PER UNIT
1	LAR130330	H-12 Bearing	2
2	LARK131250	Spring Washer, Pack of 10	2
3	LAR131230	H-32 Teflon® Lip Seal	1
4	LUAK031190	5954 Roll Pin, Pack of 20	1
5	LUCK033190	Retaining O-Ring, Pack of 5	1
6	LAR111012	H-21 Clutch Assembly	1

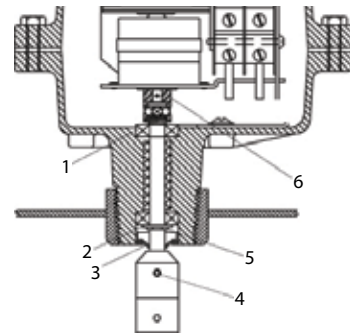



150 Venture Boulevard
Spartanburg, SC 29306
Tel: (800) 778-9242
Fax: (864) 574-8063
sales@bindicator.com
www.bindicator.com

venture
MEASUREMENT

2015 All rights reserved.
All data subject to change without notice.

LAR180312 Rev. D